

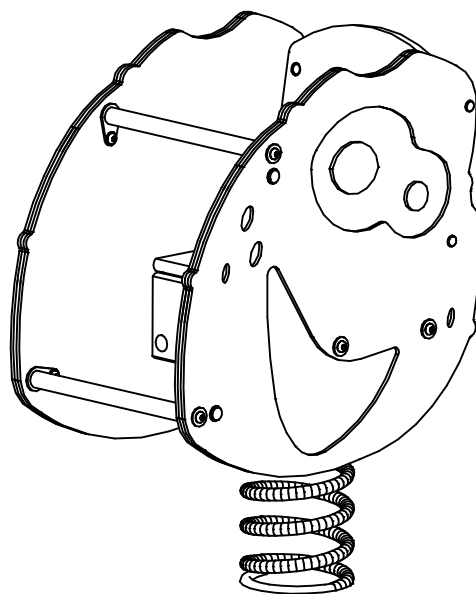





INSTALLATION INSTRUCTIONS

ZINGO YO-YO

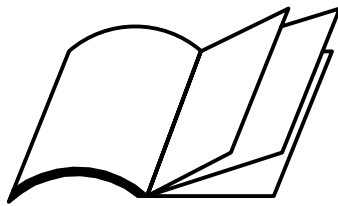
X-YOY & X-YOYD

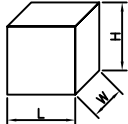
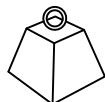

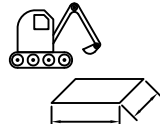
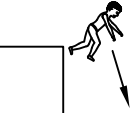

| |  LxWxH (m) |  kg |  m ³ |  m |  ≥EN1176 |  x 2= T |
|-------------------|--|---|---|---|--|--|
| TYPE 1 / 2 | 0.63 x 0.39 x 0.81 | 85 | 0.07 | 3.00 x 3.00 | 0.41m | T = 2h |
| TYPE 3 | 0.63 x 0.39 x 0.91 | | 0.05 | | 0.51m | |

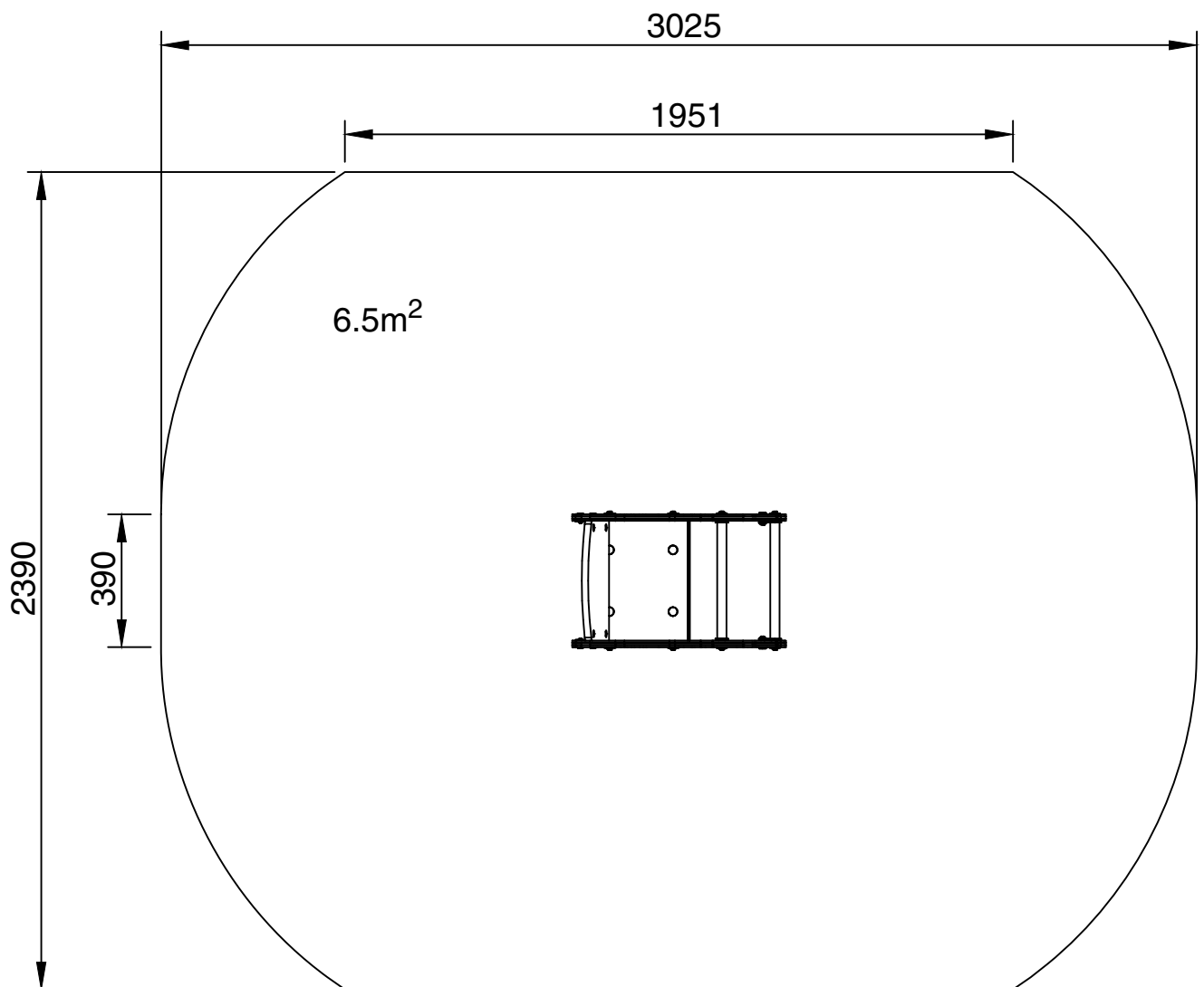

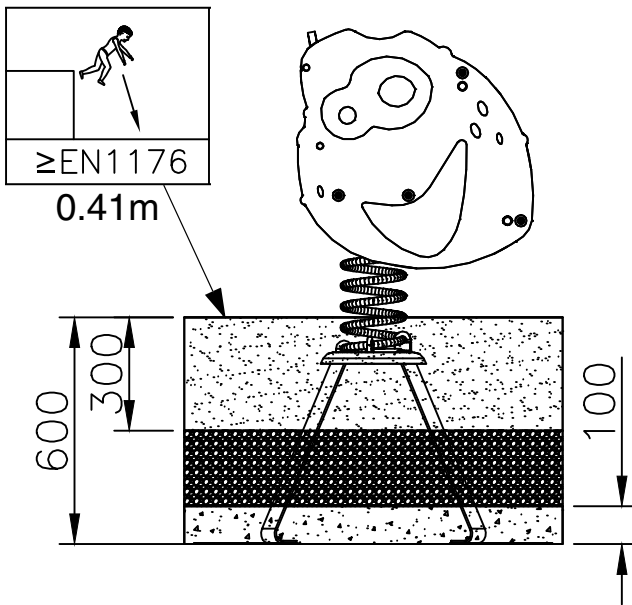
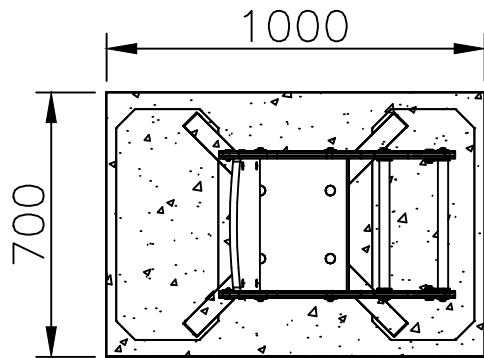
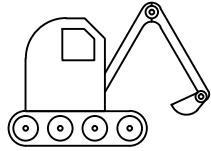

TYPE 1 / 2

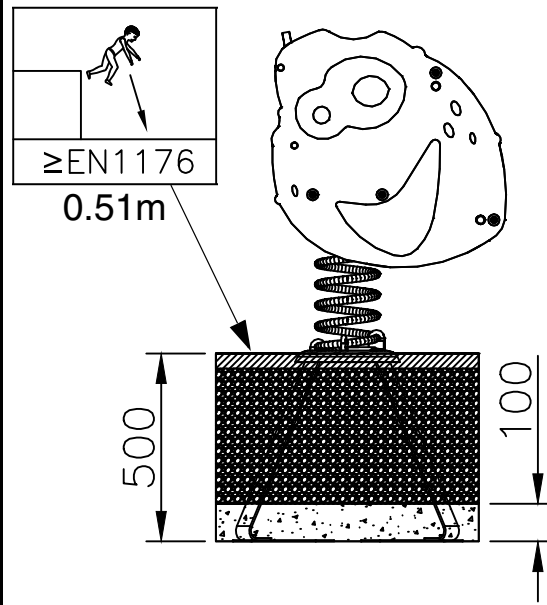
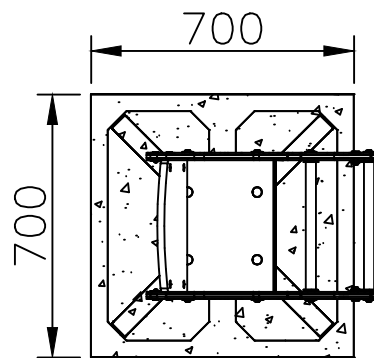
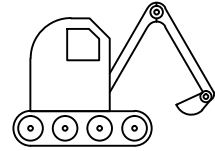

TYPE 3

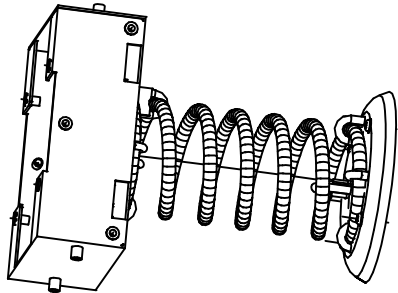
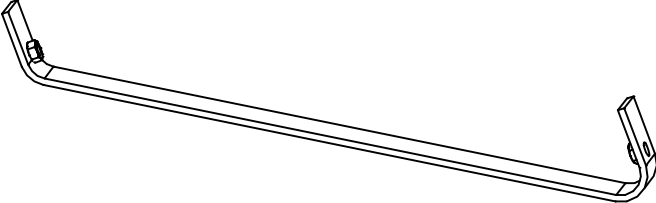
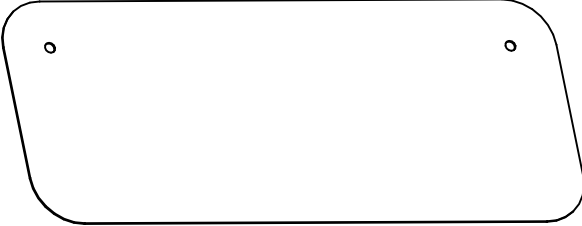
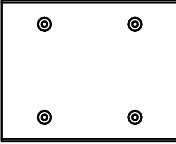
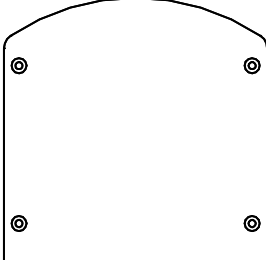
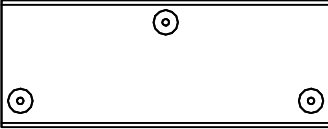
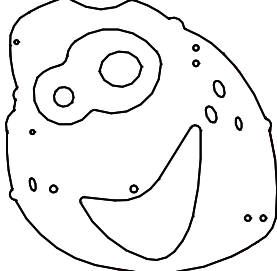
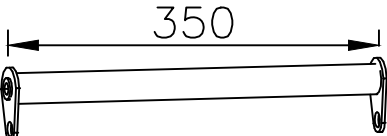

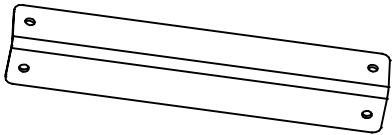
| ITEM | REF | | X-YOY | Kg. |
|------|----------|---|-------|-------|
| 1 | 86519999 |  | 1 | 24.00 |
| 2 | 86009002 |  | 4 | 1.750 |
| 3 | 86009001 |  | 2 | 2.000 |
| 4A | 86520000 |  | 1 | 1.72 |
| 4B | |  | 1 | 2.06 |
| 4C | |  | 2 | 0.86 |
| 5 | 56010010 |  | 1 | 5.90 |
| 6 | 86529001 |  | 2 | 0.70 |

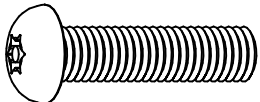
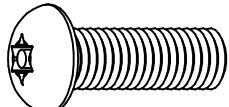
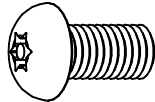
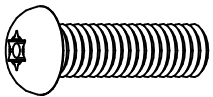
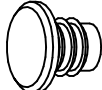
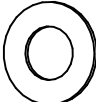
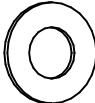
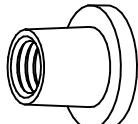
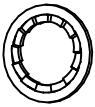
| ITEM | REF | | X-YOY | Kg. |
|------|----------|--|-------|-------|
| 7 | 86529002 |  | 2 | 0.03 |
| 8 | 19028651 |  | 10 | 0.002 |
| 9 | 10121040 |  M10 X 40 | 8 | 0.037 |
| 10 | 10121030 |  M10 X 30 | 8 | 0.028 |
| 11 | 10121020 |  M10 X 20 | 14 | 0.020 |
| 12 | 10120620 |  M6 X 20 | 8 | 0.009 |
| 13 | 10930600 |  M6 | 8 | 0.006 |
| 14 | 10291000 |  M10 11X21X1 | 22 | 0.002 |
| 15 | 10290600 |  M6 6.4X12.6X1 | 8 | 0.001 |
| 16 | 10931000 |  M10 | 4 | 0.020 |
| 17 | 10301200 |  M12 13X20X1 | 4 | 0.002 |

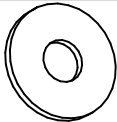
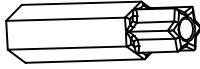
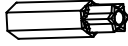
| ITEM | REF | | X-YOY | Kg. |
|------|----------|--|-------|-------|
| 18 | 10309999 |  M10 11X30X2.5 | 8 | 0.011 |
| 19 | 10121000 |  T45 M10 | 1 | - |
| 20 | 10120600 |  T30 M6 | 1 | - |

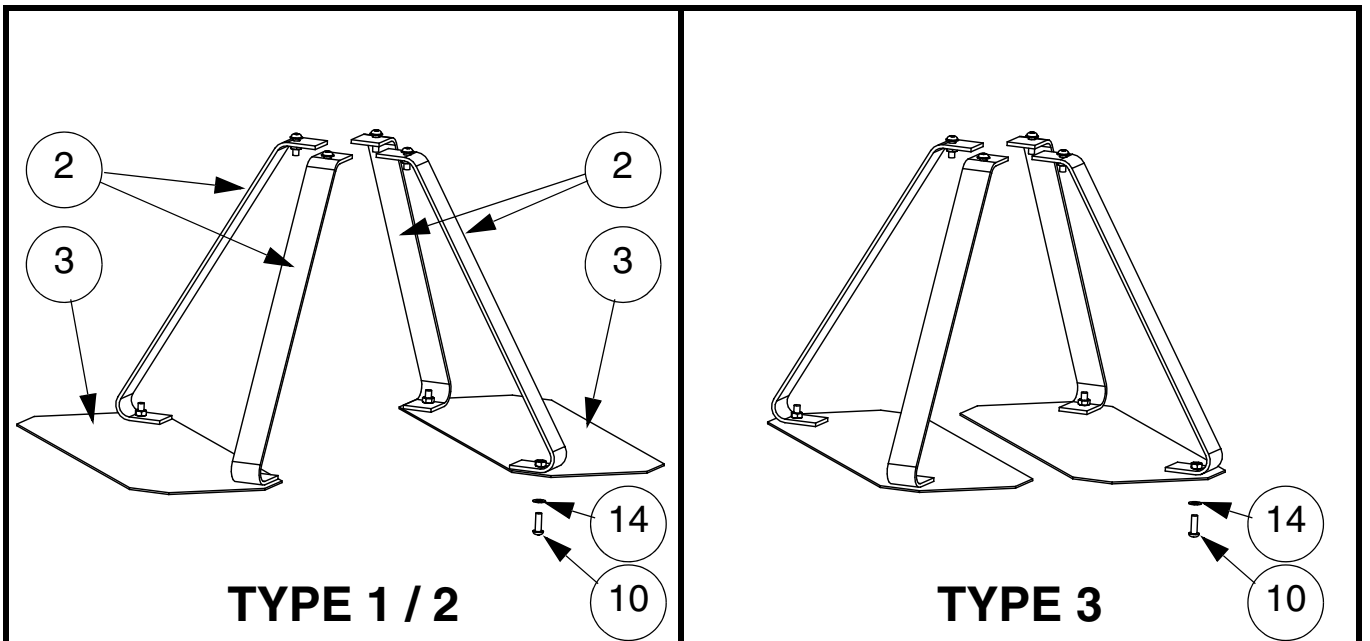

STEP 1

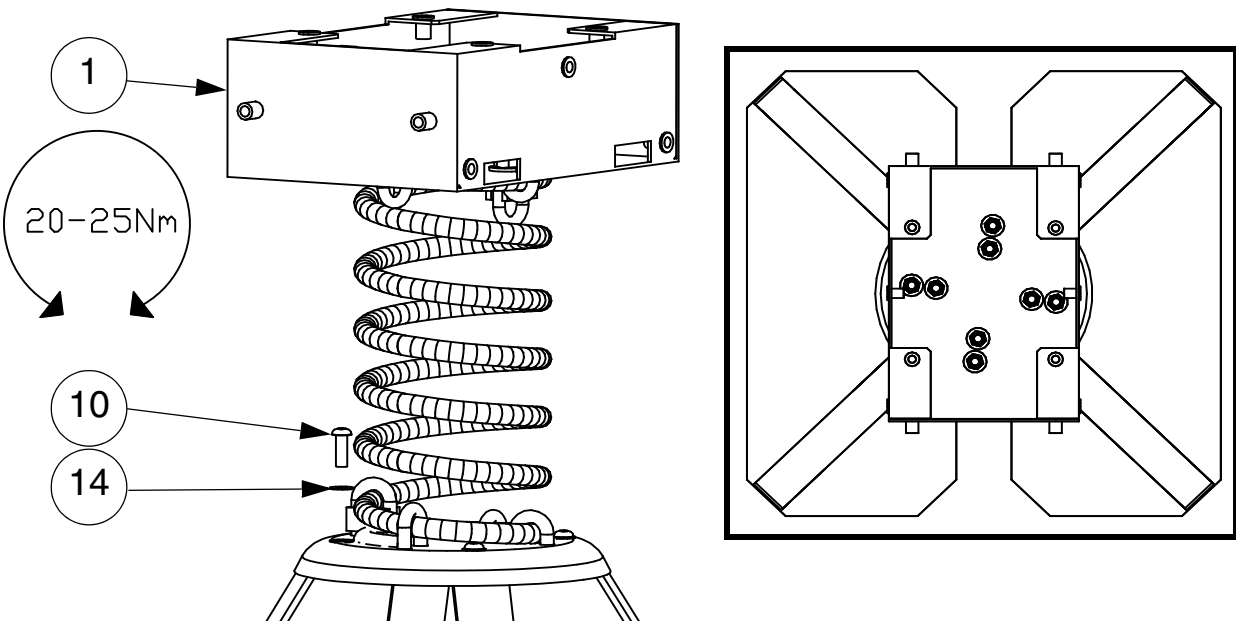

STEP 2

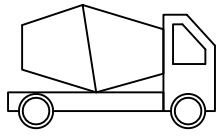

STEP 3

| |
|---|
|  |
| S2 (50mm) ≥C20-25 |
|  7 x 24h |
|  101 |



STEP 4

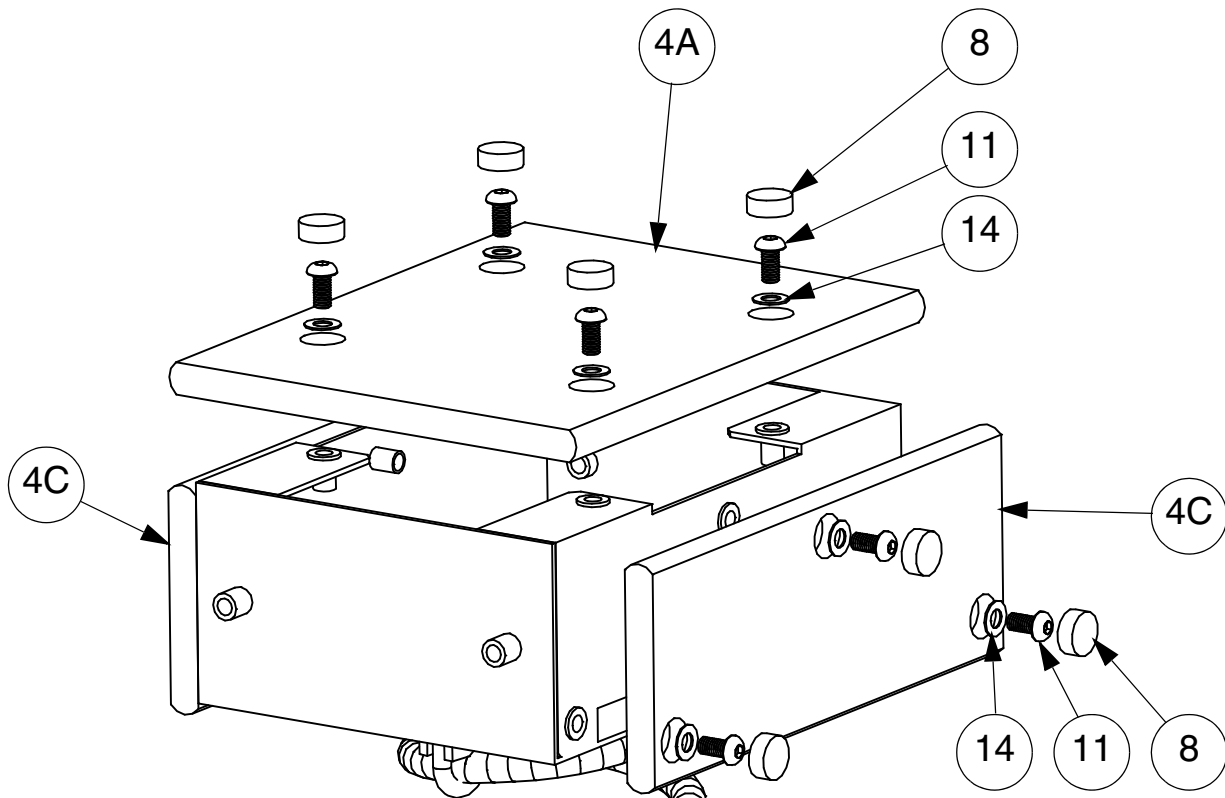

STEP 5

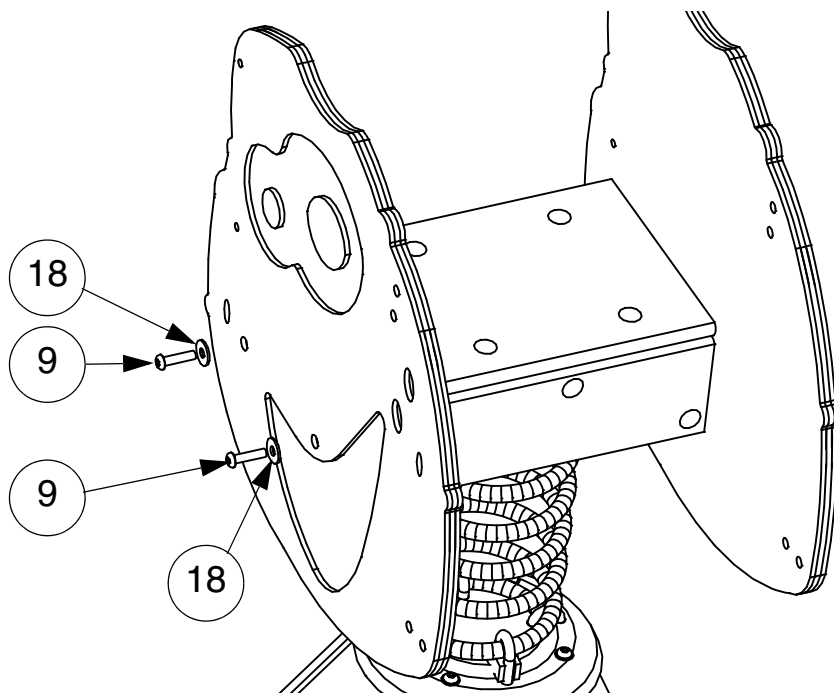

STEP 6

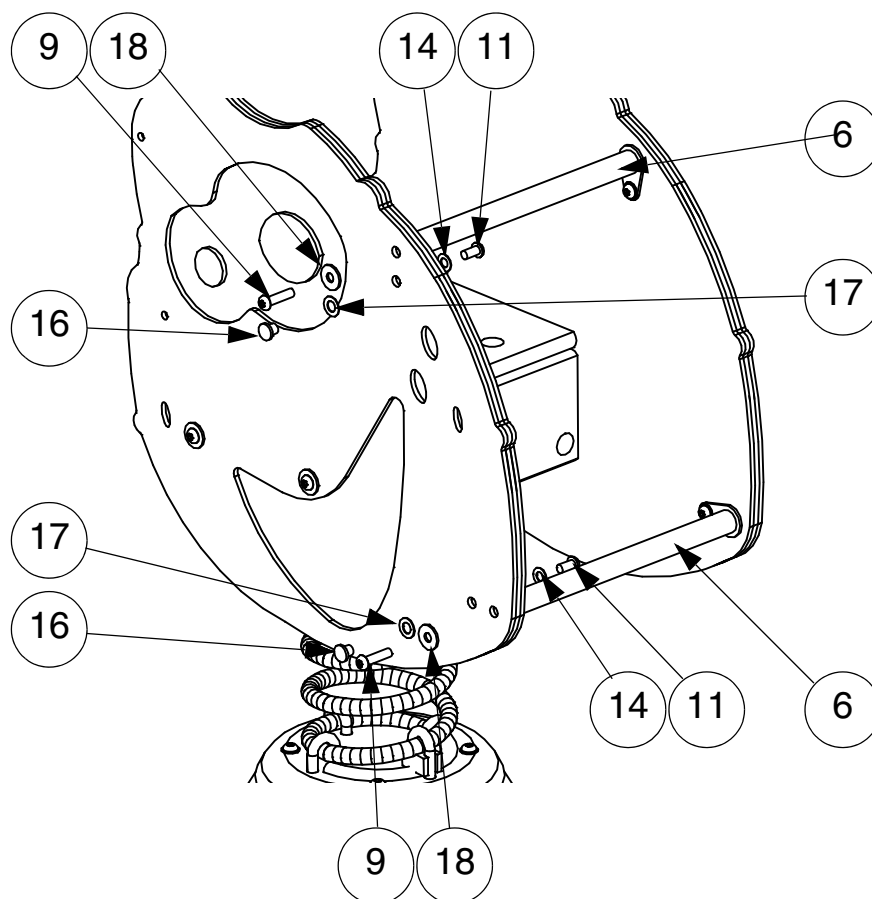

STEP 7

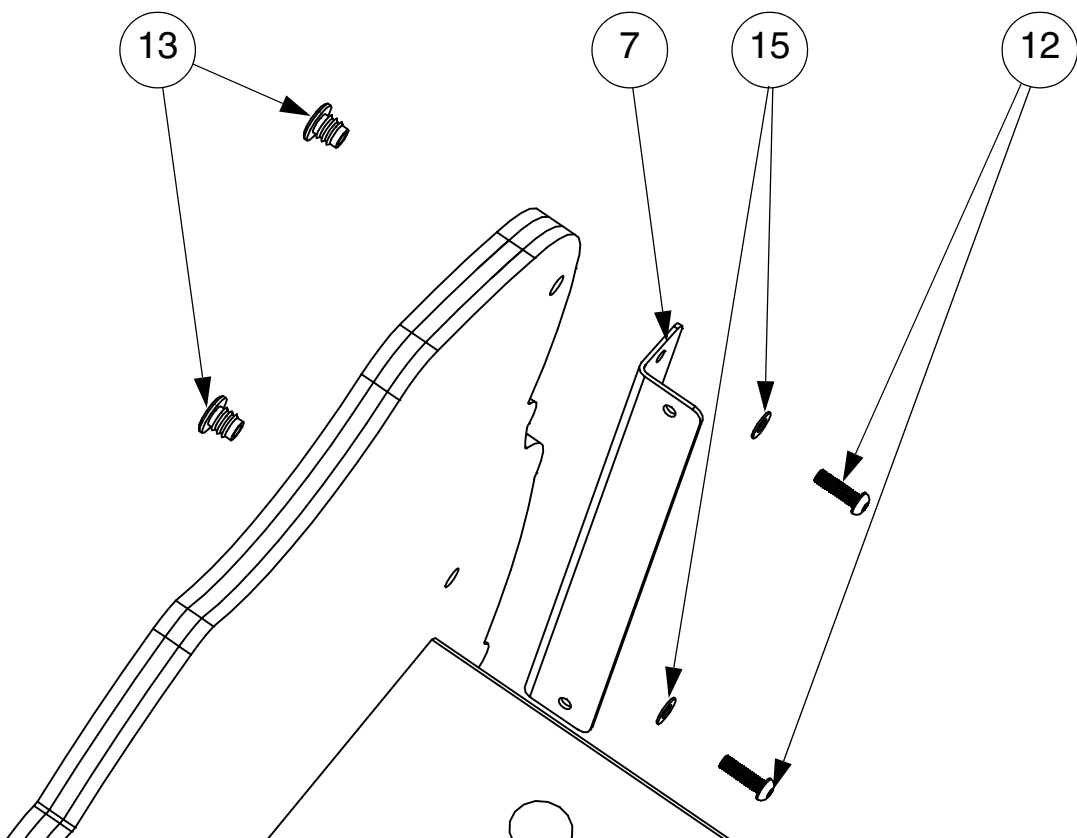

STEP 8

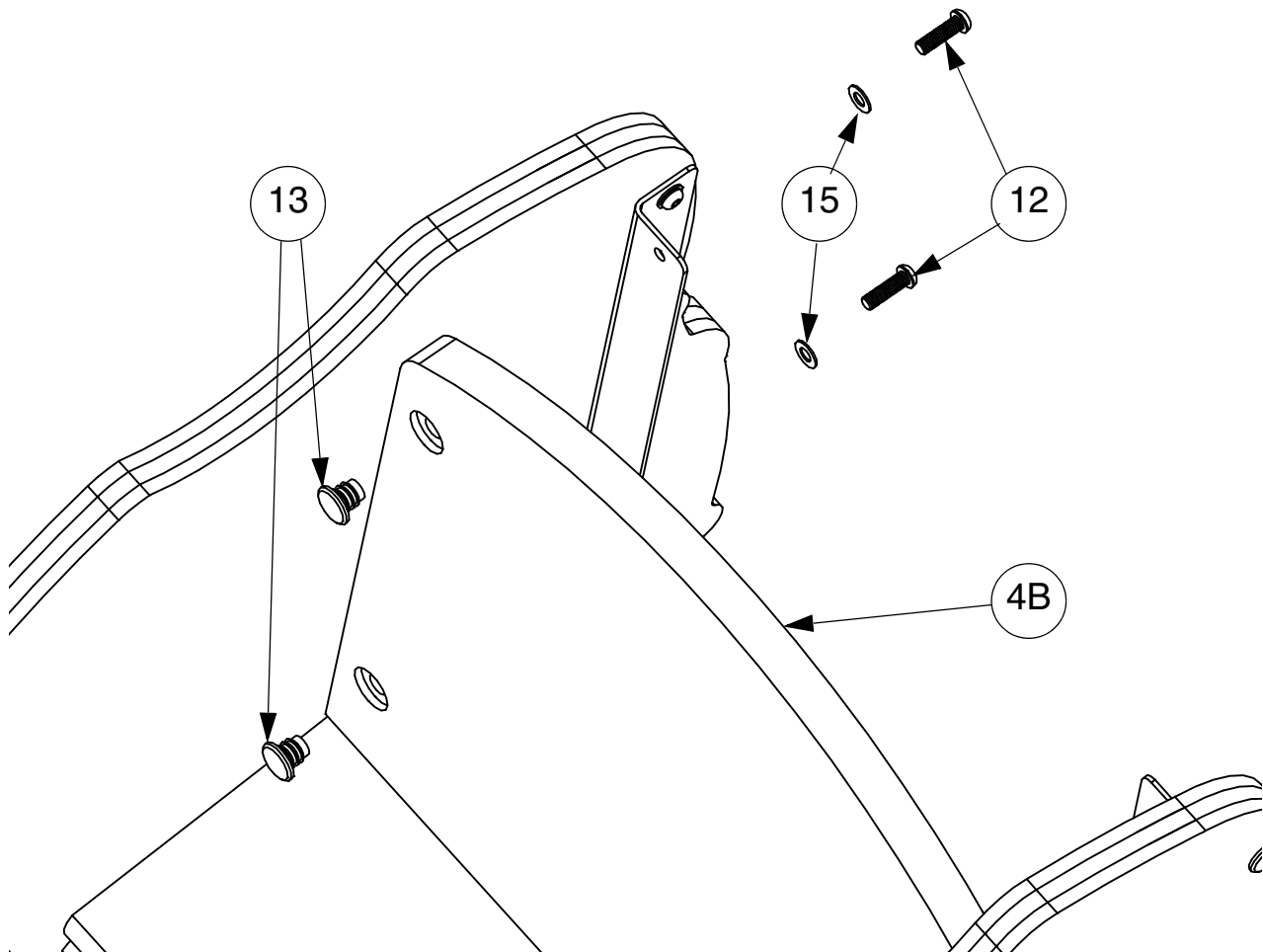

Appendix A: 86519999

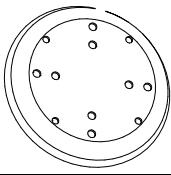
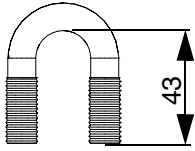
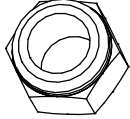
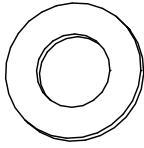
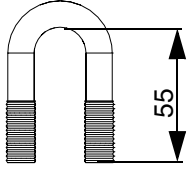
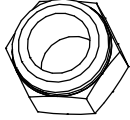
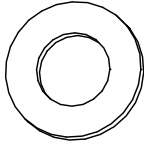
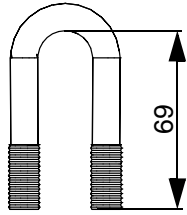
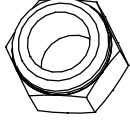
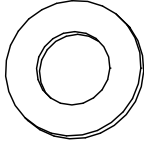
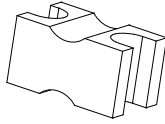
| ITEM | REF. | | QTY. | Kg. |
|------|-----------|---|------|-------|
| A1 | 86009003 |  | 1 | 2.500 |
| A2 | 86009006A |  | 4 | 0.080 |
| A3 | |  | 8 | 0.010 |
| A4 | |  | 8 | 0.003 |
| A5 | 86009006B |  | 2 | 0.100 |
| A6 | |  | 4 | 0.010 |
| A7 | |  | 4 | 0.003 |
| A8 | 86009006C |  | 2 | 0.120 |
| A9 | |  | 4 | 0.010 |
| A10 | |  | 4 | 0.003 |
| A11 | 86009007 |  | 2 | 0.001 |

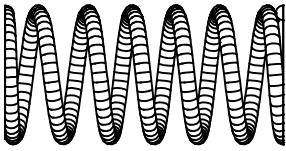
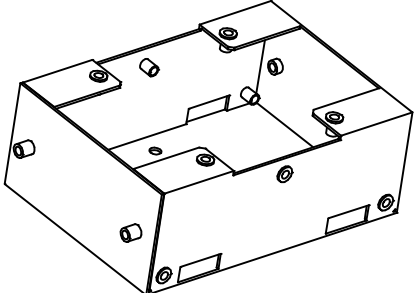
| ITEM | REF. | | QTY. | Kg. |
|------|----------|---|------|-------|
| A12 | 86009005 |  | 1 | 8.000 |
| A13 | 86519004 |  | 1 | 4.000 |

STEP 1

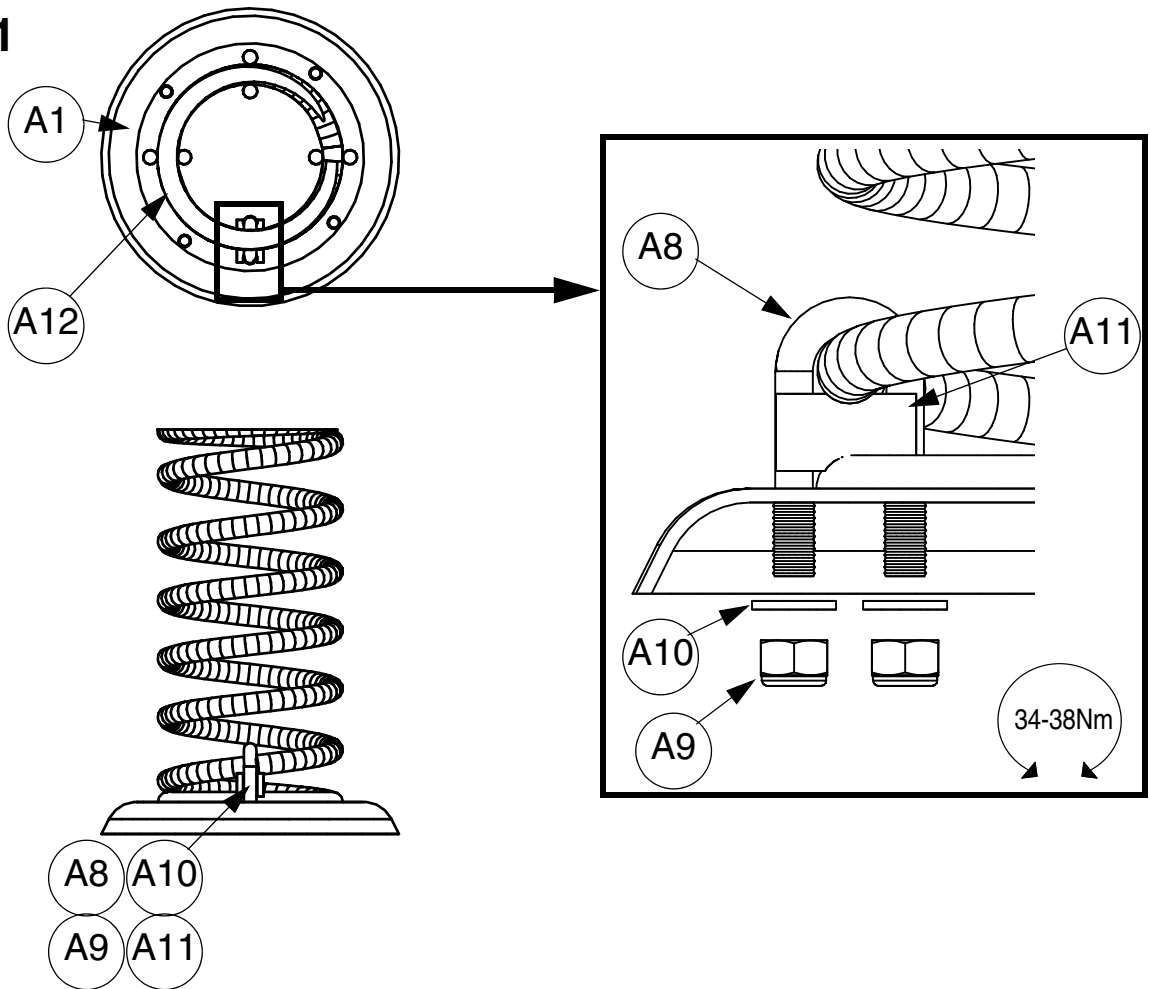

STEP 2

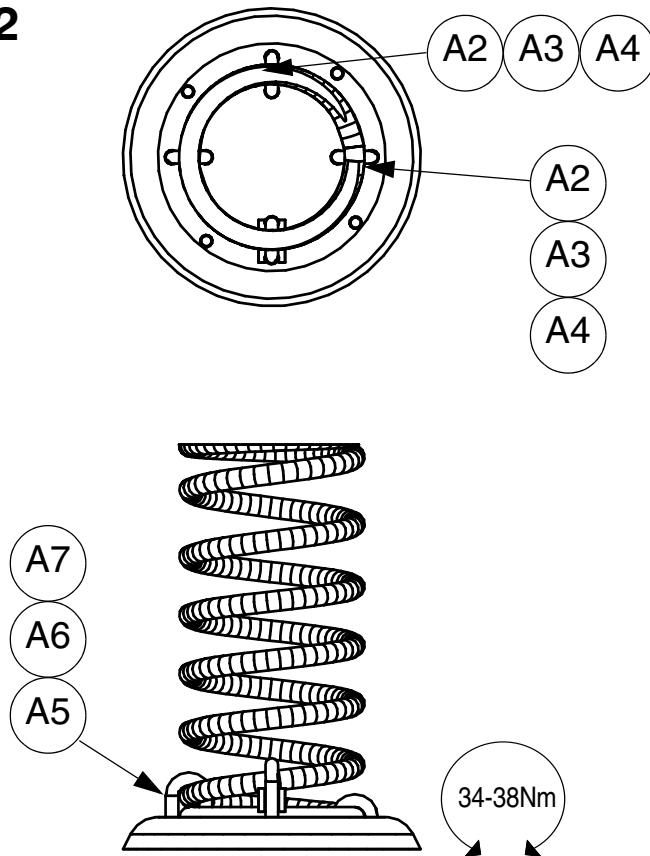

STEP 3

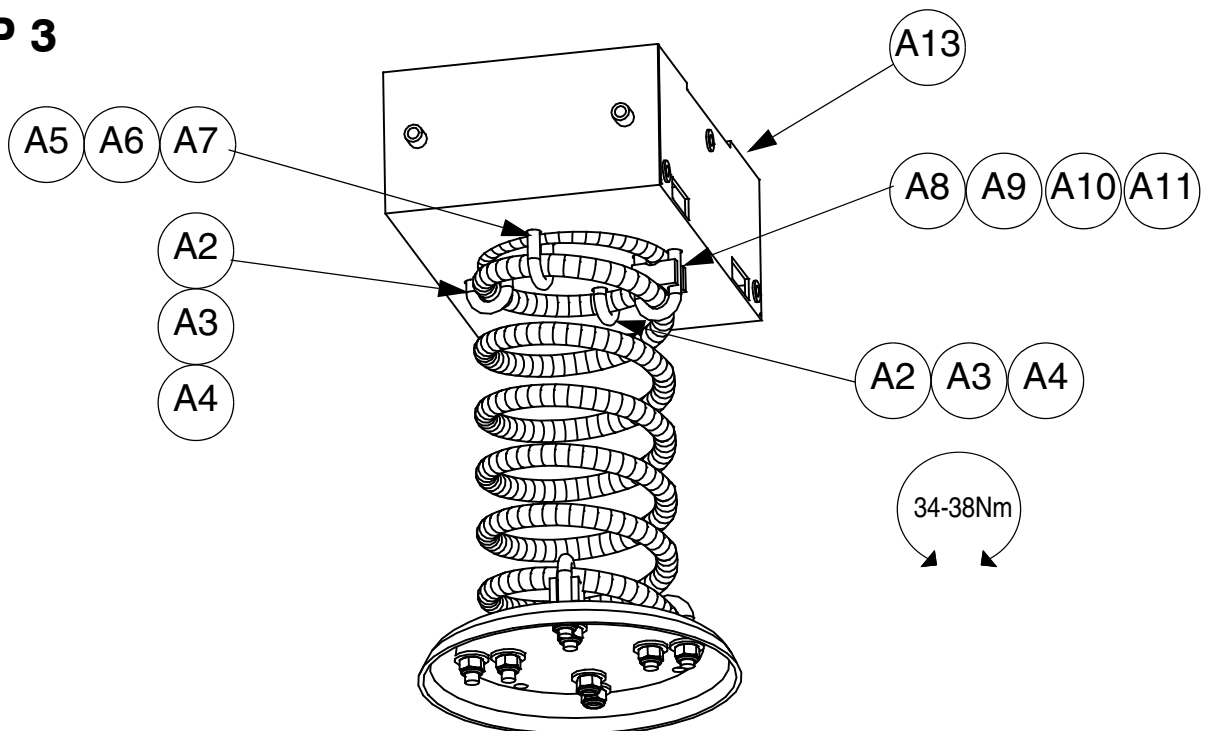

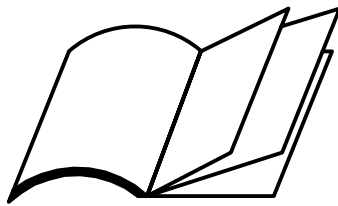

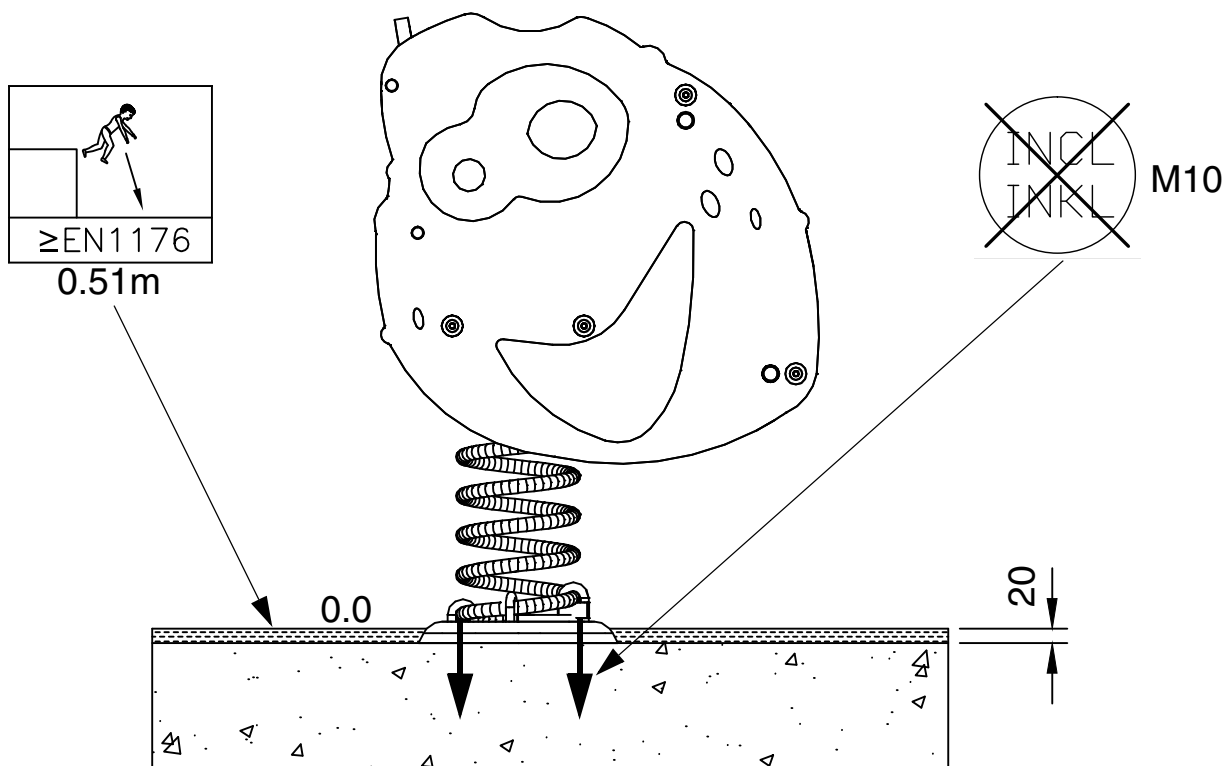

Appendix B: X-YOYOD

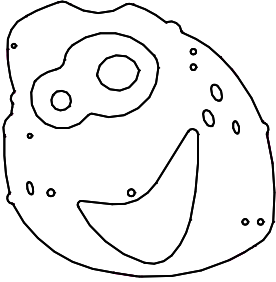
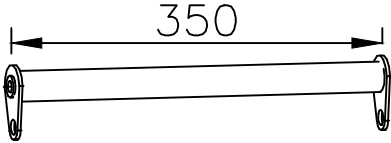
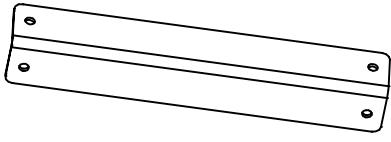

| ITEM | REF | | QTY | Kg. |
|------|----------|--|-----|-------|
| 1 | 86519999 | | 1 | 24.00 |
| 4A | 86520000 | | 1 | 1.72 |
| 4B | | | 1 | 2.06 |
| 4C | | | 2 | 0.86 |

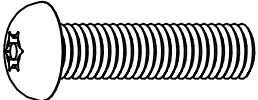
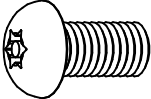
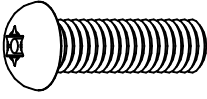
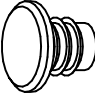
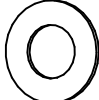
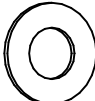
| ITEM | REF | | QTY | Kg. |
|------|----------|--|-----|-------|
| 5 | 56010010 |  | 1 | 5.90 |
| 6 | 86529001 |  | 2 | 0.70 |
| 7 | 86529002 |  | 2 | 0.03 |
| 8 | 19028651 |  | 10 | 0.002 |
| 9 | 10121040 |  <p data-bbox="576 1084 815 1122">M10 X 40</p> | 8 | 0.037 |
| 11 | 10121020 |  <p data-bbox="576 1265 815 1303">M10 X 20</p> | 14 | 0.020 |
| 12 | 10120620 |  <p data-bbox="576 1451 786 1489">M6 X 20</p> | 8 | 0.009 |
| 13 | 10930600 |  <p data-bbox="647 1635 711 1673">M6</p> | 8 | 0.006 |
| 14 | 10291000 |  <p data-bbox="555 1803 799 1841">M10 11X21X1</p> | 14 | 0.002 |
| 15 | 10290600 |  <p data-bbox="555 1980 815 2018">M6 6.4X12.6X1</p> | 8 | 0.001 |

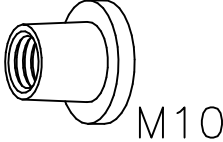
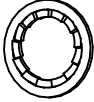
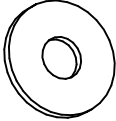
| ITEM | REF | | QTY | Kg. |
|------|----------|--|-----|-------|
| 16 | 10931000 |  M10 | 4 | 0.020 |
| 17 | 10301200 |  M12 13X20X1 | 4 | 0.002 |
| 18 | 10309999 |  M10 11X30X2.5 | 8 | 0.011 |

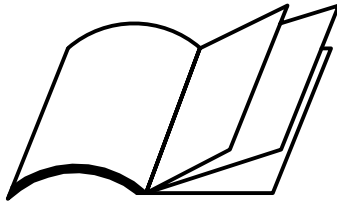

Appendix C:

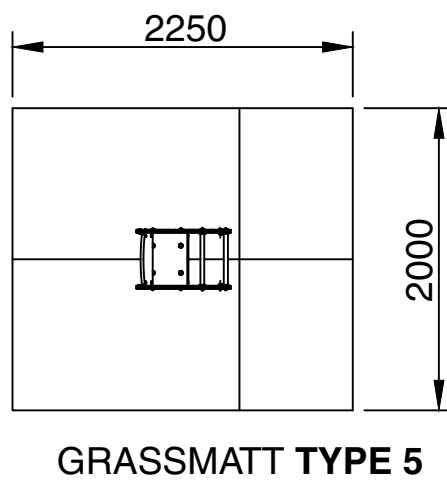
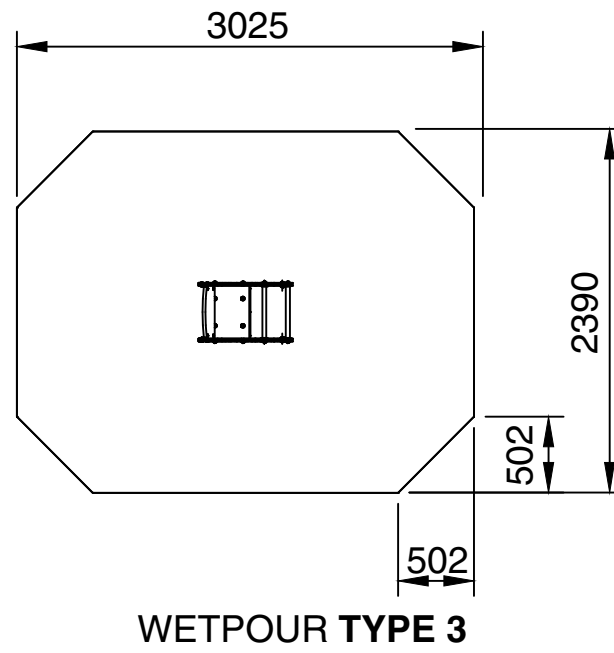
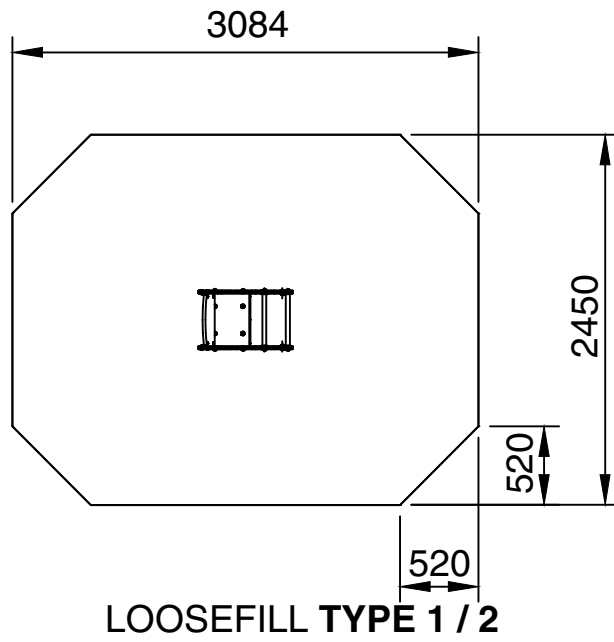

1 SAFE WORKING PRACTISE

A full risk assessment should be carried out prior to commencing the installation, which will be specific to the site selected. The major risks associated with purely the assembly of this product are highlighted below, which can form part of this overall assessment.

1.1 RISKS:

- i) Large parts which could be difficult to lift or handle.
- ii) Structure unstable until concrete footings have fully cured.
- iii) Parts at height that may require working overhead.

1.2 CONTROL MEASURES:

- i) Warn the public of the risk of injury, by placing signs and fencing the surrounding area, before commencing installation.
- ii) All staff working on installation to wear suitable PPE including Toe Protective Shoes, Hard hat and Gloves.
- iii) Any staff or other persons on site, not working directly on the installation, to be kept away from the installation.
- iv) Ensure adequate personal and equipment are on site to handle and support the structure whilst it is being assembled.

2 SPECIFICATIONS

SMP Playgrounds Ltd recommends an effective *Impact Absorbing Surface tested to EN1177 & BS7188* beneath this play equipment. Refer to manufacturers instructions for details of installation. The surface should have a Critical Fall Height greater than the Maximum Free Fall Height of the equipment.

Constructional Space is the approximate working area required to lay out and assemble the equipment.

For the safe operation of this equipment it must be installed on horizontal ground with the required minimum space.

The concrete foundations indicated are for average ground. Care should be taken concerning abnormal conditions.

If a loose fill surface is selected for this item it will require a very high level of maintenance to ensure a sufficient thickness is in place at all times to provide 'critical fall height' protection.

3 PREPARATION

All equipment assembly and fixing must conform to EN1176.

Tools / ancillary equipment: 10m tape measure, Spirit level, Torx tools (Supplied with unit), Torque wrench

3.1 ESTABLISH ORIENTATION

- i) See Specifications for equipments 'Minimum space'.
- ii) Measure out the site to ensure the space required fits into the allotted area, it is horizontal and free from trip points or other obstructions.
- iii) Ensure the equipment is to be provided with an effective Impact Absorbing Surface which has a tested critical fall height rating greater than the maximum Free Fall Height of the equipment.

3.2 MARK OUT HOLES

Consult SMP layout drawing for structure position on site.

See page 4 for concrete foundation size.

NOTE: This is a minimum guide only.

3.3 ESTABLISH DATUM LEVEL

- i) If a rubber tiled Impact Absorbing surface is to be laid, see separate instructions (base may incorporate up to 2% falls etc).
- ii) If equipment is to sit in loose fill or wet pour rubber surfaces allowances will need to be made for its recommended thickness. Generally it is recommended that loose fill surfaces are installed to a minimum depth of 300mm, however, with certain loose fill materials a greater depth may be required. This will need to be determined by allowing 100mm for the dispersal in addition to the thickness required for the particular Free Fall Height. The foundation illustrated will allow for a thickness up to 300mm.

PRE-INSTALLATION INSPECTION

Inspect all parts for damage (that may have occurred during transportation & storage). Finish Coatings, if found to be damaged these should be made good before erection (Refer to maintenance instructions). Any damaged or missing parts must be replaced.

4 INSTALLATION & ASSEMBLY PROCEDURES

- 1) Refer to site layout for position and orientation of product, then, mark the outline of the position of the footings with e.g. spray or chalk etc. Excavate the holes. **See Page 4**
- 2) Note if the installation is 'standard (TYPE 3)' or 'loose fill (TYPE 1 / 2)', then assemble the base supports (item 2) to the base plates (item 3) the appropriate way round using 4-off M10 x 30 Torx bolts (item 10) and washers (item 14) and fully secure. **STEP 1**
- 3) Align the base sub-assy onto the spring sub-assy (item 1) in the angular position shown. **STEP 2**
- 4) Assemble the spring sub-assy (item 1) onto the base sub-assy using 4-off M10 x 30 Torx bolts (item 10) and washers (item 14). Tighten Torx bolts to a torque setting between 20-25 Nm. **STEP 2**
- 5) Position completed assembly into the bottom of the excavation shim as required and check position and orientation. Ensure the assembly is plumb and square and at correct height.
- 6) Fill hole with concrete to the correct height, taking into account any impact absorbing surfacing requirements. Ensure full volume of concrete is used. (**See Page 4**) **STEP 3**

Concrete mix is recommended at:
 1 part cement;
 2 parts sand;
 4 parts aggregate;
 by volume with 20mm aggregate
 (20 N/mm² min compressive strength)

- 7) Keep installation off limits to the public until concrete has completely cured. (Recommended initial curing time 48hrs minimum).
- 8) Place seat panel (item 4A) onto spring & base sub-assy and secure into place using 4 off M10 x 20 Torx bolts (item 11) and plain washer (item 14). Tighten bolts to a torque setting between 20-25 Nm. **STEP 4**
- 9) Place cover panels (item 4C) onto spring & base sub-assy and secure into place using 3 off M10 x 20 Torx bolts (item 11) and plain washer (item 14). Tighten bolts to a torque setting between 20-25Nm. **STEP 4**
- 10) Tap plastic cap (item 8) into recess on seat and cover panels ensuring they finish flush with surrounding plastic surface with no sharp edges. **STEP 4**
- 11) Locate both side panels onto spring & base sub-assy Secure assembly from the outside of the side panels using M10 x 40 Torx bolts (item 9) and M10 Heavy Duty washers (item 18). **STEP 5**
- 12) Secure 2 off Tie bars into position from the inside of the side panels using M10 x 40 Torx bolts (item 9) and M10 plain washers (item 14). Locate M12 Shockproof washer (item 17) on to M10 Tee nut (item 16) and press into holes from outside of side panels, Then secure in position using M10 x 20 Torx bolts (item 11). Tighten bolts to a torque setting between 20-25 Nm. **STEP 6**
- 13) Insert tee nut (item 13) into side panel (item 5) from the outside and position support bracket (item 7) on inside of side panel and secure using 2 off M6 x 20 Torx bolts (item 12) and plain washer (item 15). **STEP 7**

-
- 14) Insert tee nut (item 13) into recessed side of back panel (item 4B) and position on support bracket (item 7) and secure using 2 off M6 x 20 Torx bolts (item 12) and plain washer (item 15). Tighten bolts to a torque setting between 3-5Nm. **STEP 8**

5 POST INSTALLATION INSPECTION

CHECK

- | CHECK | CHECK | ✓ |
|--|--------------------------|---|
| 1 The unit is installed at the correct seat height. | <input type="checkbox"/> | |
| 2 All fixings are tightened to the correct torque and have no protruding sharp edges. | <input type="checkbox"/> | |
| 3 Paint work is not damaged. | <input type="checkbox"/> | |
| 4 The polyethylene is not damaged. | <input type="checkbox"/> | |
| 5 Concrete foundations are secure. | <input type="checkbox"/> | |
| 6 Concrete has a water shed away from legs. | <input type="checkbox"/> | |
| 7 Adequate provision of impact absorbing surfacing and no obstructions or trip points within the equipments falling space. | <input type="checkbox"/> | |
| 8 Site is clear of all tools and rubbish. | <input type="checkbox"/> | |
| 9 Remove any warning signs. | <input type="checkbox"/> | |