

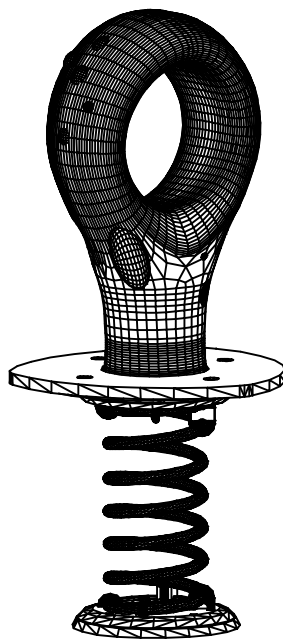





INSTALLATION INSTRUCTIONS

ZINGO BOING

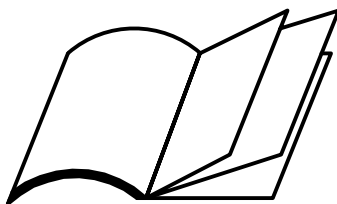
X-BSB & X-BSBD

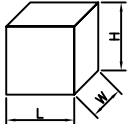
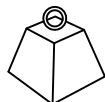

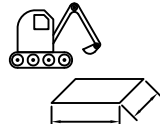
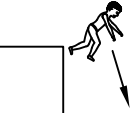



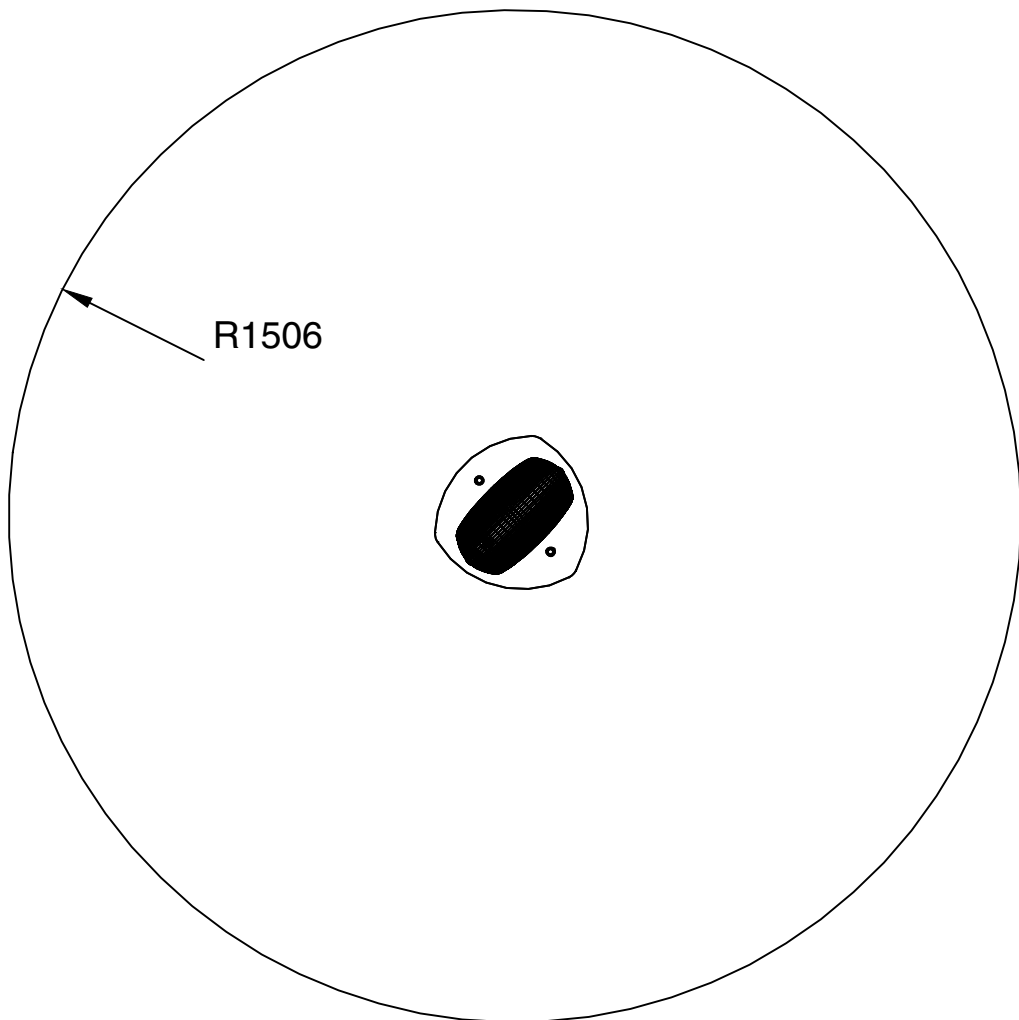

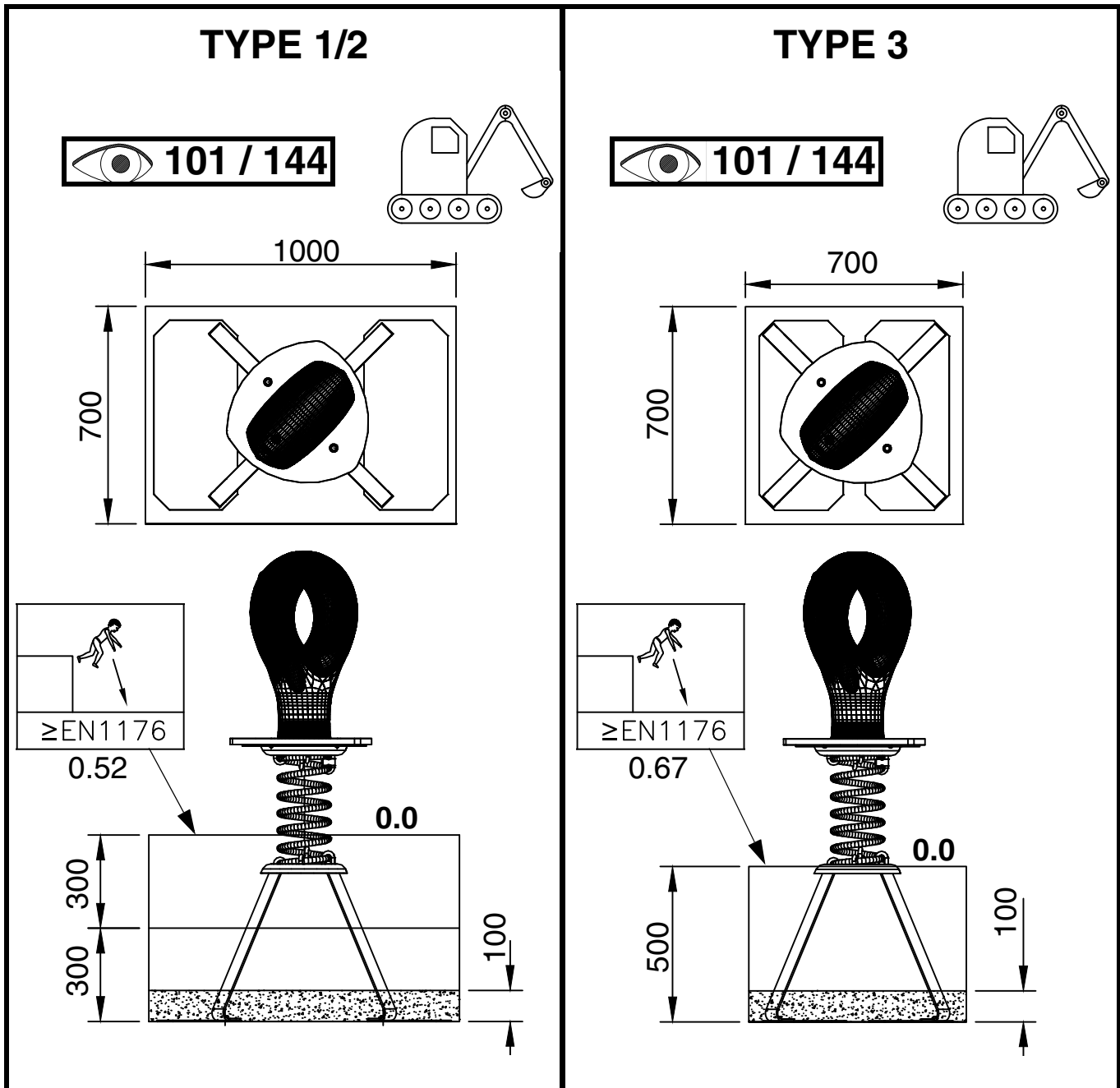
	 LxWxH (m)	 kg	 m ³	 m	 ≥EN1176	 x 2 = T
TYPE 1 / 2	Ø0.49 x 1.00	34	0.07	Ø4	0.52m	T = 2h
TYPE 3			0.05		0.67m	

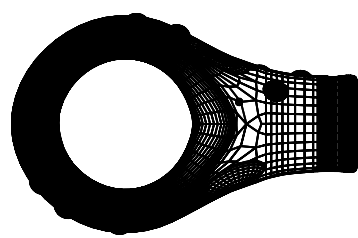
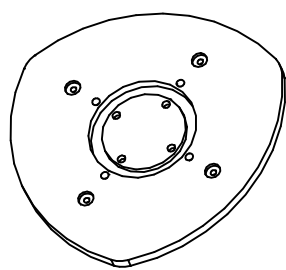

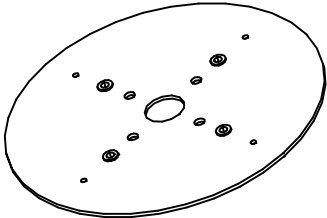
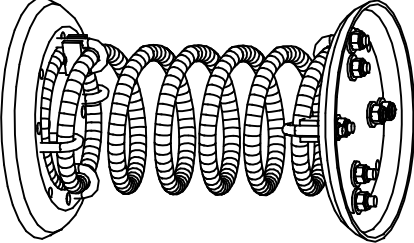
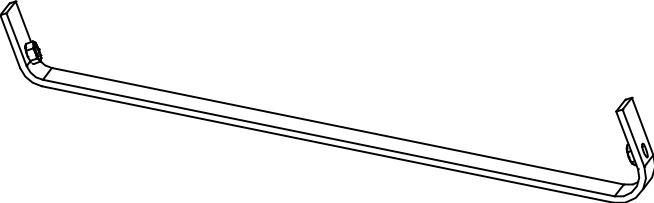
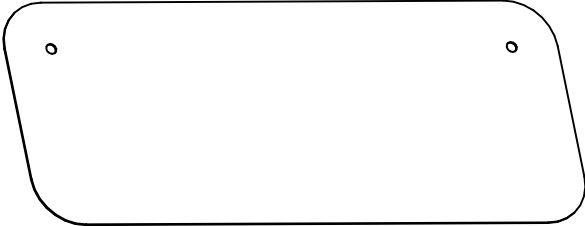
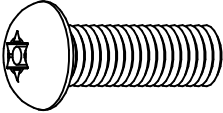
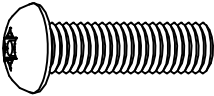
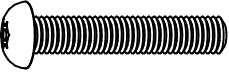
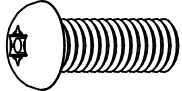

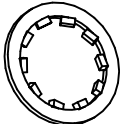
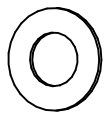
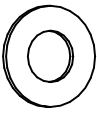
ITEM	REF		QTY.	kg.
1	55070030		1	3.00
2	56030020		1	2.50

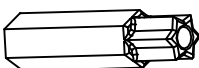
ITEM	CODE	DESCRIPTION	QTY.	WEIGHT kg.
3	56030010		1	5.00
4	56029999		1	23.0
5	86009002		4	2.50
6	86009001		2	2.50
7	10121030	 M10 X 30	8	0.028
8	10121035	 M10 X 35	4	0.032
9	10121065M	 M10 X 55	4	0.048
10	10120616	 M6 X 16	4	0.007

ITEM	CODE	DESCRIPTION	QTY.	WEIGHT kg.
11	10301000	 M10 12X18X1	4	0.002
12	10291000	 M10 11X21X1	12	0.002
13	10290600	 M6 6.4X12.6X1	4	0.001
14	10930600	 M6	4	0.006
15	10121000	 T45 M10	1	-
16	10120600	 T30 M6	1	-

STEP 1

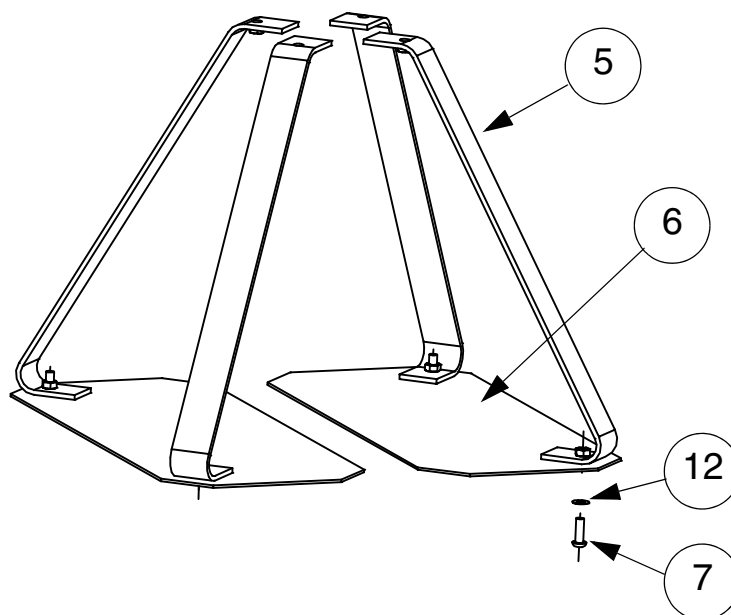

STEP 2

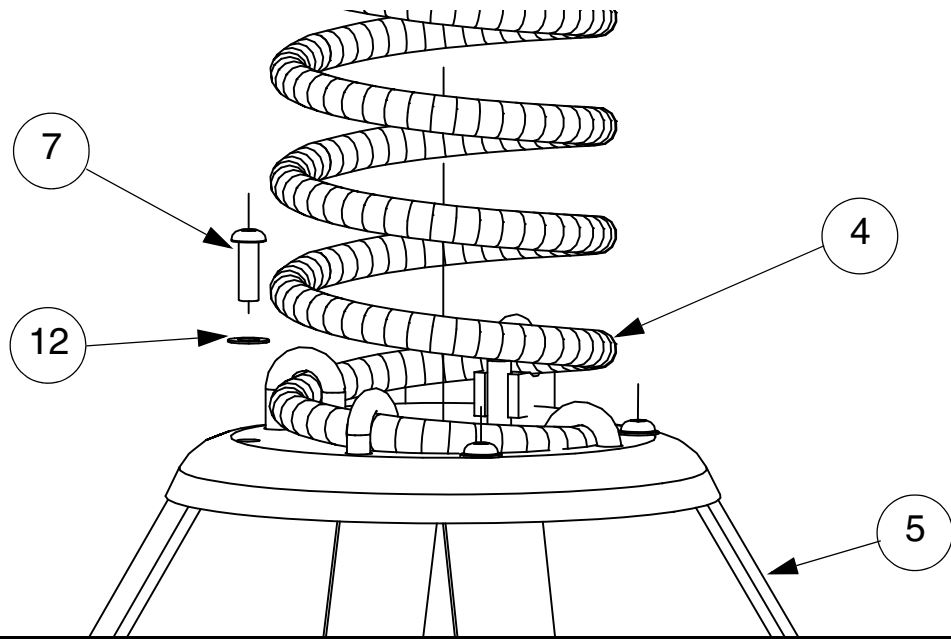

STEP 3

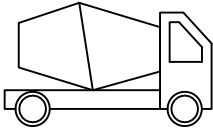
S2 (50mm)
≥C20-25
🕒 7 x 24h
👁️ 101

STEP 4

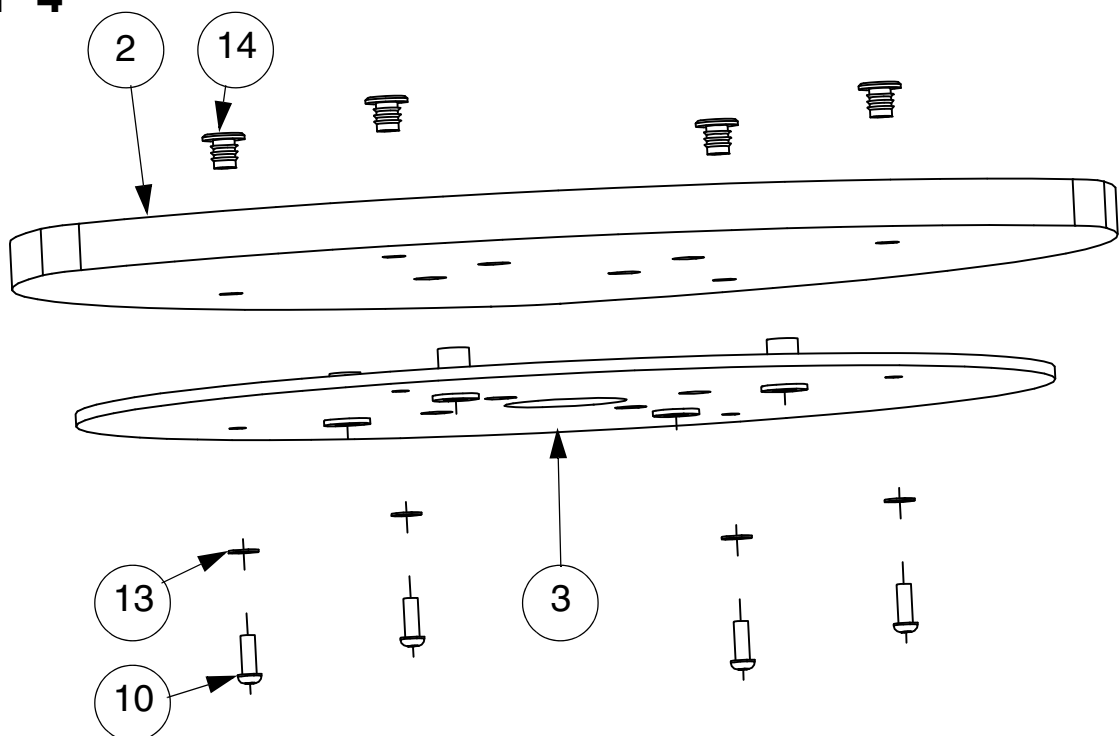

STEP 5

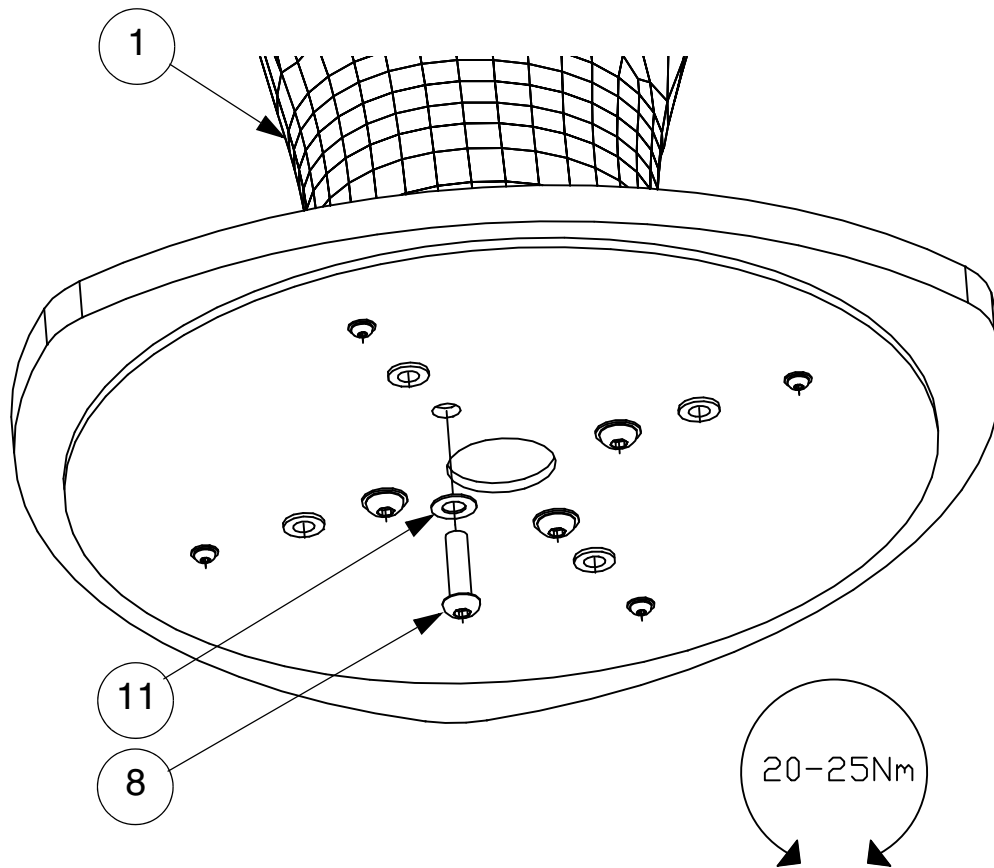



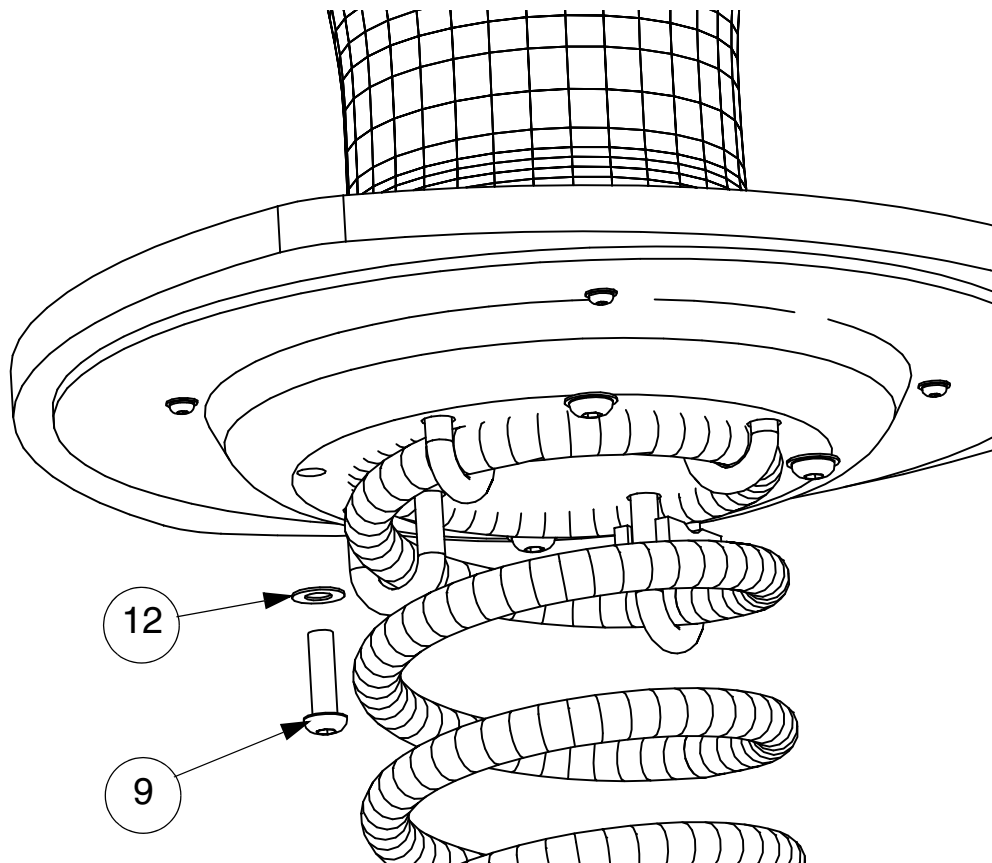



STEP 6

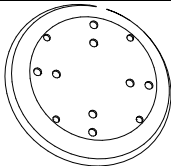
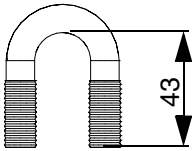
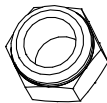

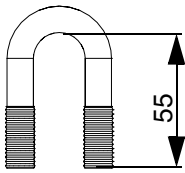
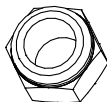
Appendix A:

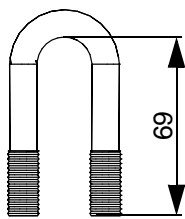
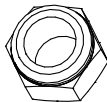
REF 56029999

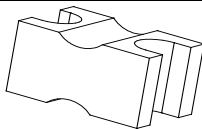
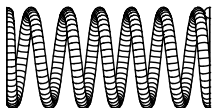
ITEM	REF		QTY.	WEIGHT Kg.
A1	86009003		2	2.500
A2	86009006A		4	0.080
A3			8	0.010
A4			8	0.003
A5	86009006B		2	0.100
A6			4	0.010
A7			4	0.003
A8	86009006C		2	0.120
A9			4	0.010
A10			4	0.003
A11	86009007		2	0.001
A12	86009005		1	8.000

STEP 1

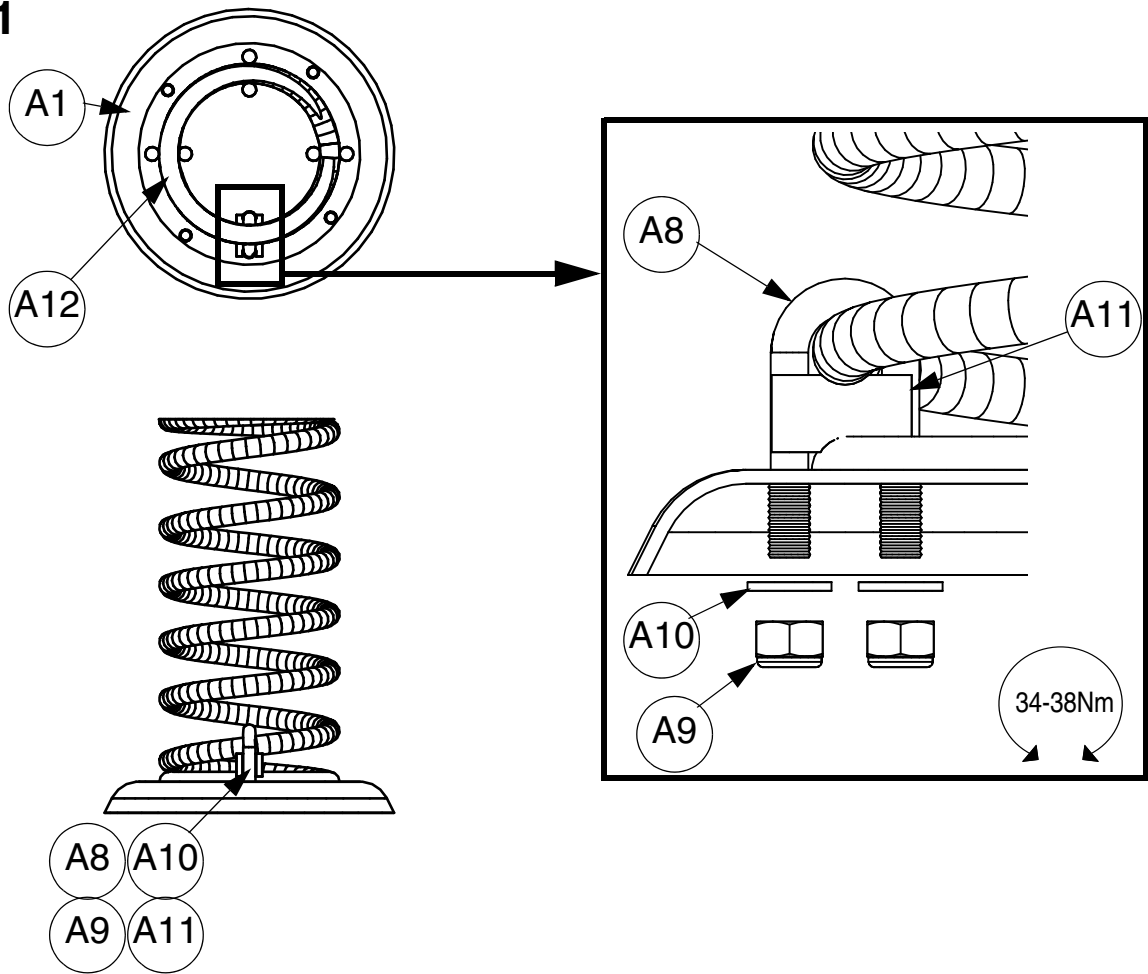

STEP 2

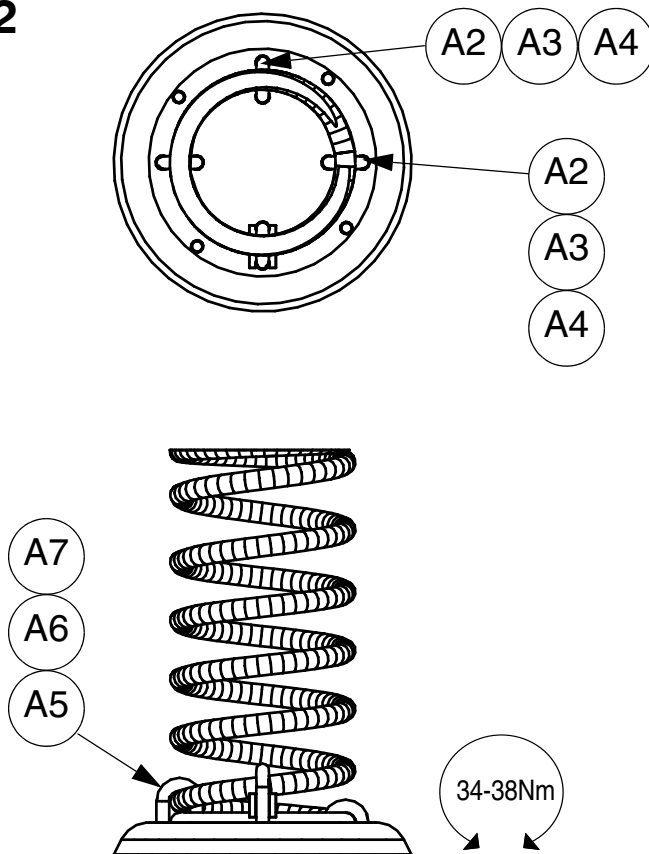

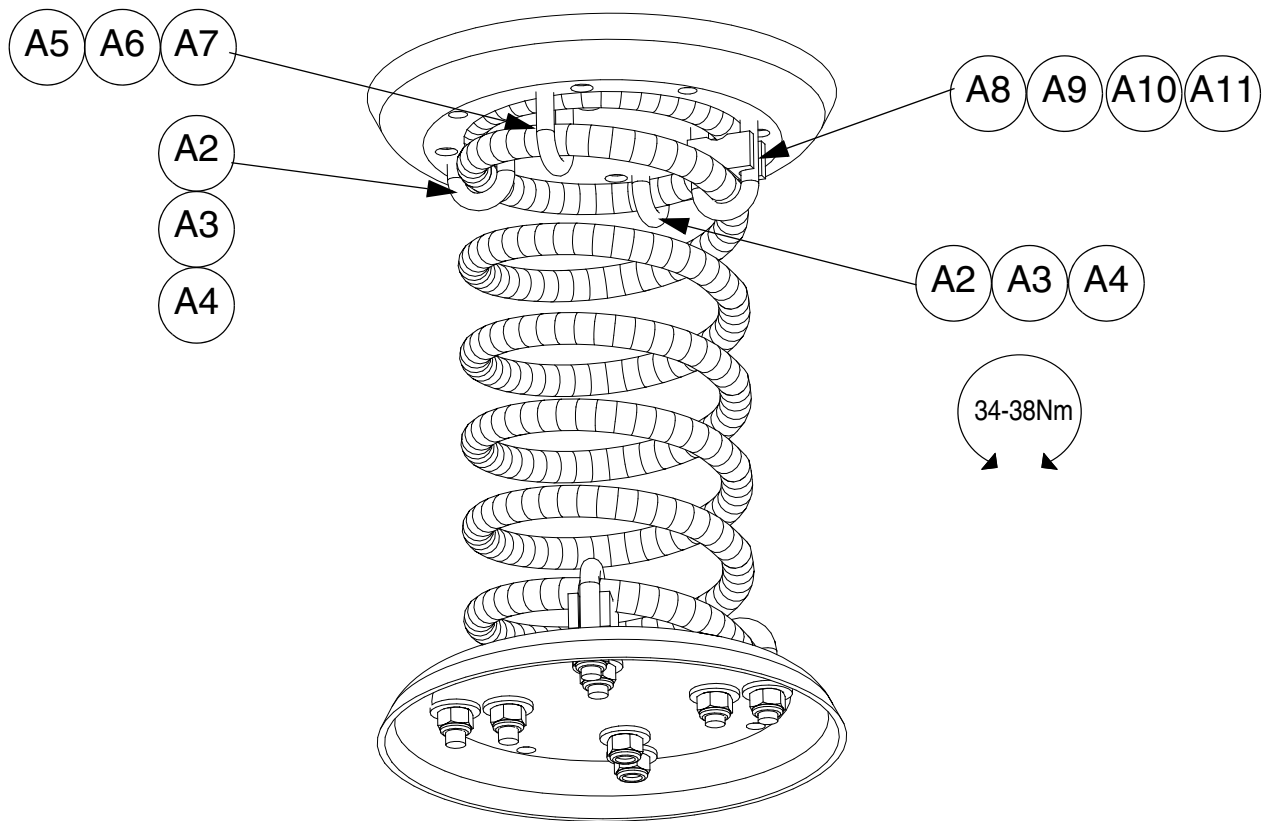

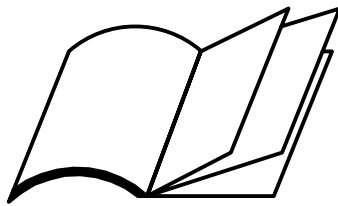

STEP 3

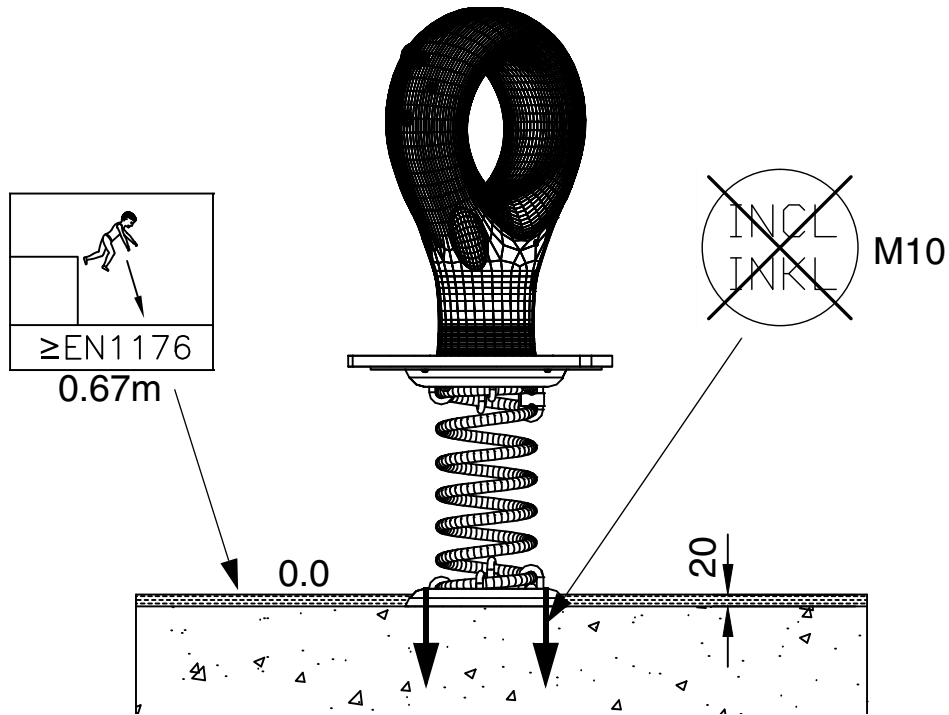

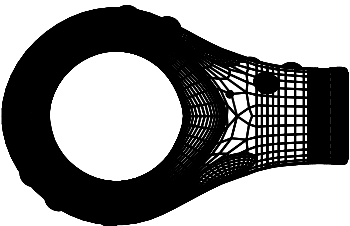
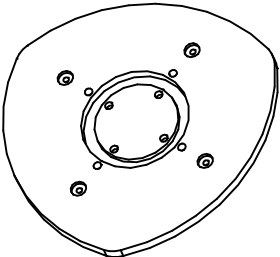
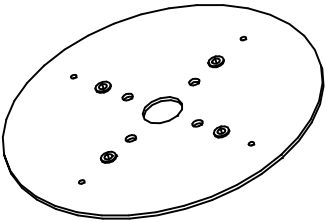
Appendix B: X-BSBD

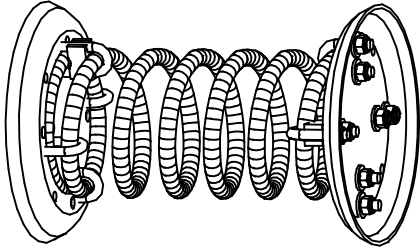
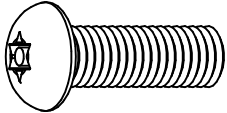
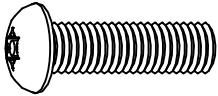

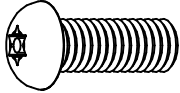
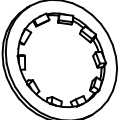
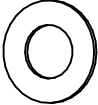
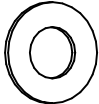
ITEM	REF		QTY.	kg.
1	55070030		1	3.00
2	56030020		1	2.50
3	56030010		1	5.00

ITEM	REF		QTY.	kg.
4	56029999		1	23.0
7	10121030	 M10 X 30	4	0.028
8	10121035	 M10 X 35	4	0.032
9	10121065M	 M10 X 55	4	0.048
10	10120616	 M6 X 16	4	0.007
11	10301000	 M10 12X18X1	4	0.002
12	10291000	 M10 11X21X1	8	0.002
13	10290600	 M6 6.4X12.6X1	4	0.001
14	10930600	 M6	4	0.006

Appendix C:

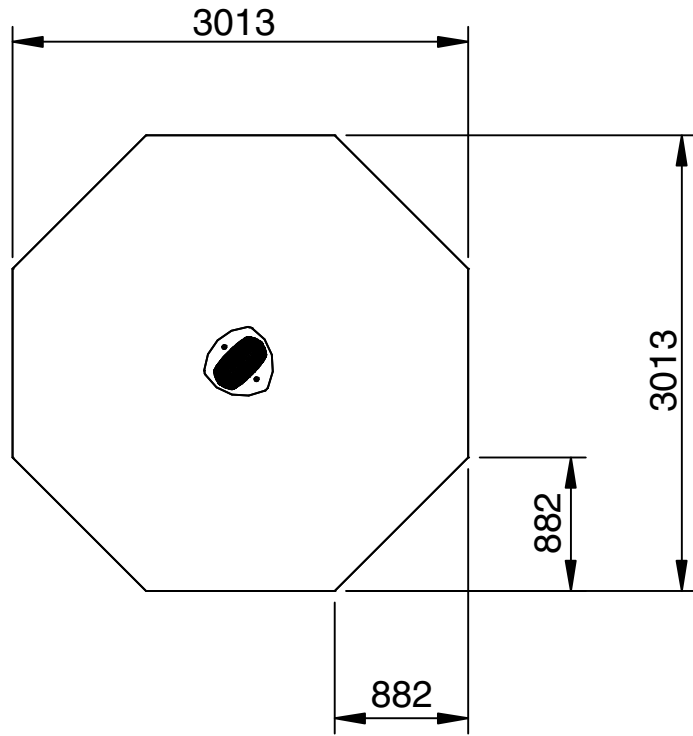

WET POUR AREA

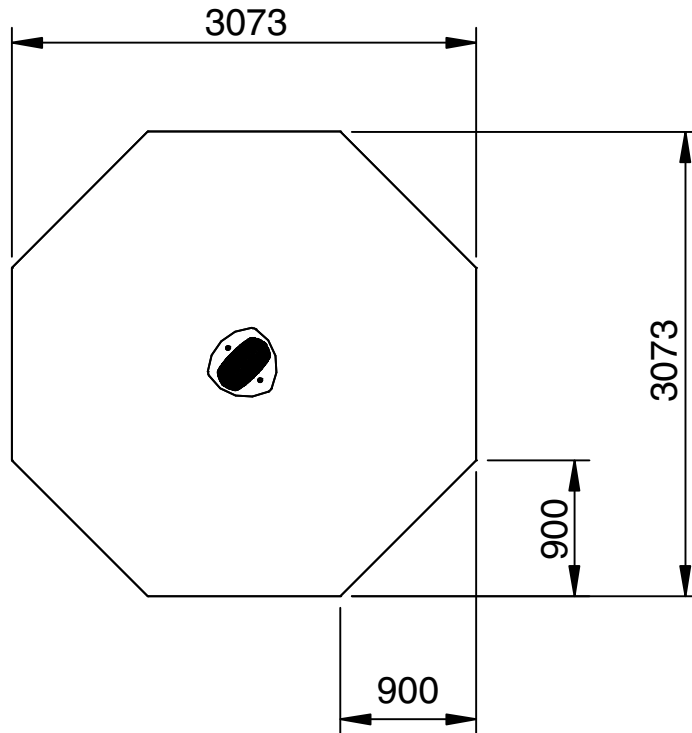

LOOSE FILL AREA

1 SAFE WORKING PRACTISE

A full risk assessment should be carried out prior to commencing the installation, which will be specific to the site selected. The major risks associated with purely the assembly of this product are highlighted below, which can form part of this overall assessment.

1.1 RISKS:

- i) Large parts which could be difficult to lift or handle.
- ii) Structure unstable until concrete footings have fully cured.
- iii) Parts at height that may require working overhead.

1.2 CONTROL MEASURES:

- i) Warn the public of the risk of injury, by placing signs and fencing the surrounding area, before commencing installation.
- ii) All staff working on installation to wear suitable PPE including Toe Protective Shoes, Hard hat and Gloves.
- iii) Any staff or other persons on site, not working directly on the installation, to be kept away from the installation.
- iv) Ensure adequate personal and equipment are on site to handle and support the structure whilst it is being assembled.

2 SPECIFICATIONS

SMP Playgrounds Ltd recommends an effective *Impact Absorbing Surface tested to EN1177 & BS7188* beneath this play equipment. Refer to manufacturers instructions for details of installation. The surface should have a Critical Fall Height greater than the Maximum Free Fall Height of the equipment.

Constructional Space is the approximate working area required to lay out and assemble the equipment.

For the safe operation of this equipment it must be installed on horizontal ground with the required minimum space.

The concrete foundations indicated are for average ground. Care should be taken concerning abnormal conditions.

If a loose fill surface is selected for this item it will require a very high level of maintenance to ensure a sufficient thickness is in place at all times to provide 'critical fall height' protection.

3 PREPARATION

All equipment assembly and fixing must conform to EN1176.

Tools / ancillary equipment: 10m tape measure, Spirit level, Torx tools (Supplied with unit), Torque wrench

3.1 ESTABLISH ORIENTATION

- i) See Specifications for equipments 'Minimum space'.
- ii) Measure out the site to ensure the space required fits into the allotted area, it is horizontal and free from trip points or other obstructions.
- iii) Ensure the equipment is to be provided with an effective Impact Absorbing Surface which has a tested critical fall height rating greater than the maximum Free Fall Height of the equipment.

3.2 MARK OUT HOLES

Consult SMP layout drawing for structure position on site.

See **page 4** for concrete foundation size.

NOTE: This is a minimum guide only.

3.3 ESTABLISH DATUM LEVEL

- i) If a rubber tiled Impact Absorbing surface is to be laid, see separate instructions (base may incorporate up to 2% falls etc).
- ii) If equipment is to sit in loose fill or wet pour rubber surfaces allowances will need to be made for its recommended thickness. Generally it is recommended that loose fill surfaces are installed to a minimum depth of 300mm, however, with certain loose fill materials a greater depth may be required. This will need to be determined by allowing 100mm for the dispersal in addition to the thickness required for the particular Free Fall Height. The foundation illustrated will allow for a thickness up to 300mm.

PRE-INSTALLATION INSPECTION

Inspect all parts for damage (that may have occurred during transportation & storage). Finish Coatings, if found to be damaged these should be made good before erection (Refer to maintenance instructions). Any damaged or missing parts must be replaced.

4 INSTALLATION & ASSEMBLY PROCEDURES

- i) Refer to site layout for position and orientation of product, then, mark the outline of the position of the footings with e.g. spray or chalk etc. Excavate the holes. See **Page 4**
- ii) Assemble the base supports (item 5) to the base plates (item 6), the appropriate way round, using 4 off M10 x 30 Resistorx bolts (item 7) and M10 washers (item 12) and fully secure. **STEP 1**
- iii) Secure base support (item 5) onto the Spring Assembly (item 4) and secure using 4 off M10 x 30 Resistorx bolts (item 7) and M10 washers (item 12). **STEP 2**
- iv) Position completed assembly into the bottom of the excavation shim as required and check position and orientation. Ensure the assembly is plumb and square and at correct height. See **Page 4**
- v) Fill hole with concrete to the height, taking into account any impact absorbing surfacing requirements. Ensure full volume of concrete is used.

Concrete mix is recommended at:
 1 part cement;
 2 parts sand;
 4 parts aggregate;
 by volume with 20mm aggregate
 (20 N/mm² min. compressive strength)

- vi) Keep installation off limits to the public until concrete has completely cured. (Recommended initial curing time 48hrs minimum). **STEP 3**
- vii) Insert 4 off Tee Nut (item 14) into the Boing Platform (item 2) and attach to the Spring Mounting Plate (item 3) using 4 off M6 x 16 Resistorx bolts (item 9) and washers (item 13). The recess in the Boing Platform should be on the opposite face to the Spring Mounting Plate and tighten the Resistorx bolts to a torque setting between 3-5 Nm. **STEP 4**
- viii) Assemble the Small Moulding Fixed (item 1) to the assembled platform using 4 off M10 x 35 Resistorx bolts (item 8) and shockproof washers (item 11). **Ensure that the moulding has a metal insert set inside at the mounting end before completing assembly.** Tighten the Resistorx bolts to a torque setting between 20-25 Nm. **STEP 5**
- ix) Attach the assembled platform to the ground mounting using 4 off M10 x 55 Resistorx bolts (item 9) and shockproof washers (item 11). **STEP 6**
- x) Check that all parts are assembled correctly and tighten the Resistorx bolts to a torque setting between 20-25 Nm.

5 POST INSTALLATION INSPECTION

CHECK	CHECK
1 The unit is installed at the correct seat height.	<input checked="" type="checkbox"/>
2 All fixings are tightened to the correct torque and have no protruding sharp edges.	<input type="checkbox"/>
3 Paint work and Polyethylene is not damaged. (Any making good should be carried out using the procedure in the Inspection and Maintenance instructions).	<input type="checkbox"/>
4 Concrete foundations are secure.	<input type="checkbox"/>
5 Concrete has a water shed away from legs.	<input type="checkbox"/>
6 Adequate provision of impact absorbing surfacing.	<input type="checkbox"/>
7 Site is clear of all tools and rubbish.	<input type="checkbox"/>
8 No trip points or other obstructions within the minimum space.	<input type="checkbox"/>
9 Remove any warning signs.	<input type="checkbox"/>