

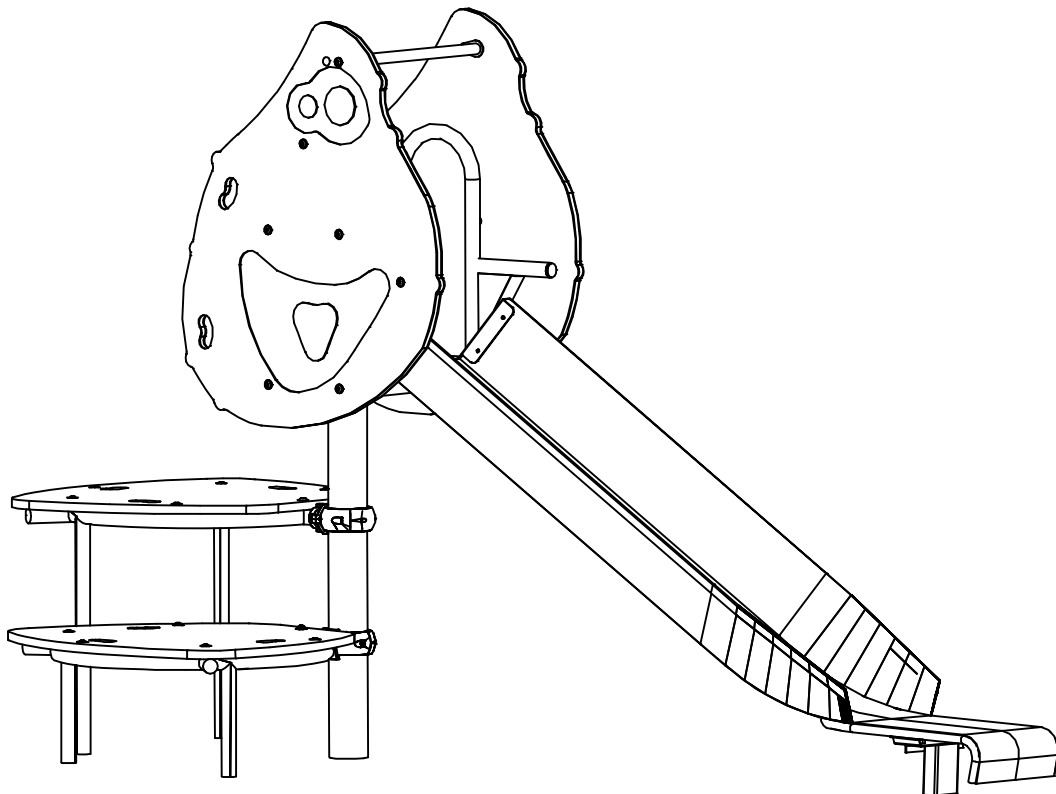

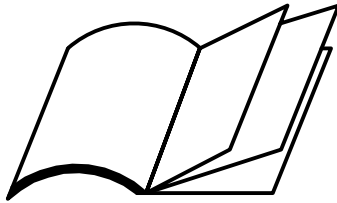



**INSTALLATION INSTRUCTIONS**  
**LITTLE ZINGO SLIDE**

**X-0900/S**

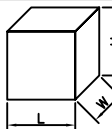
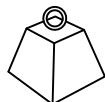

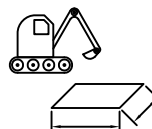
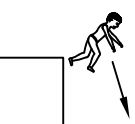

						
	LxWxH (m)	kg	m <sup>3</sup>	m	≥EN1176	x 2= T
X-0900/S	2.75 x 1.18 x 1.69	130	0.28	7.50 x 6.50	1.0m	T= 4h

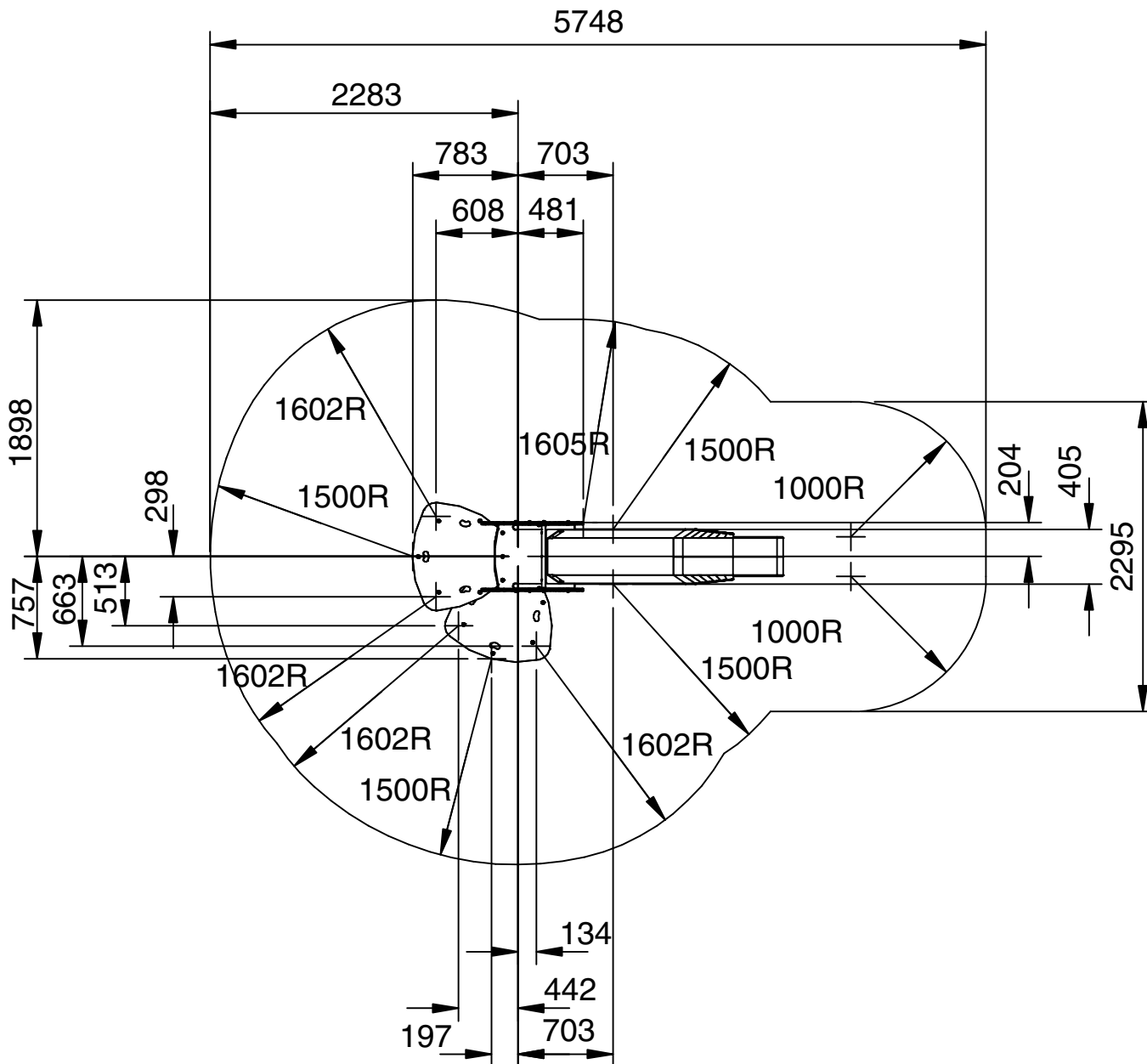

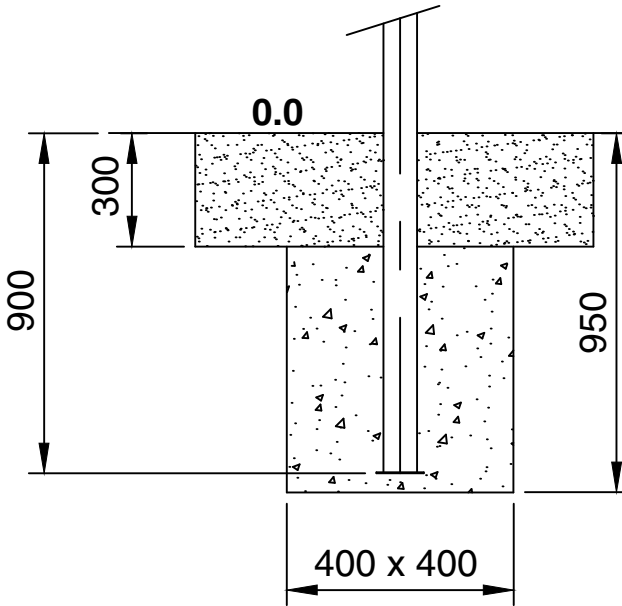

# X-0900/S



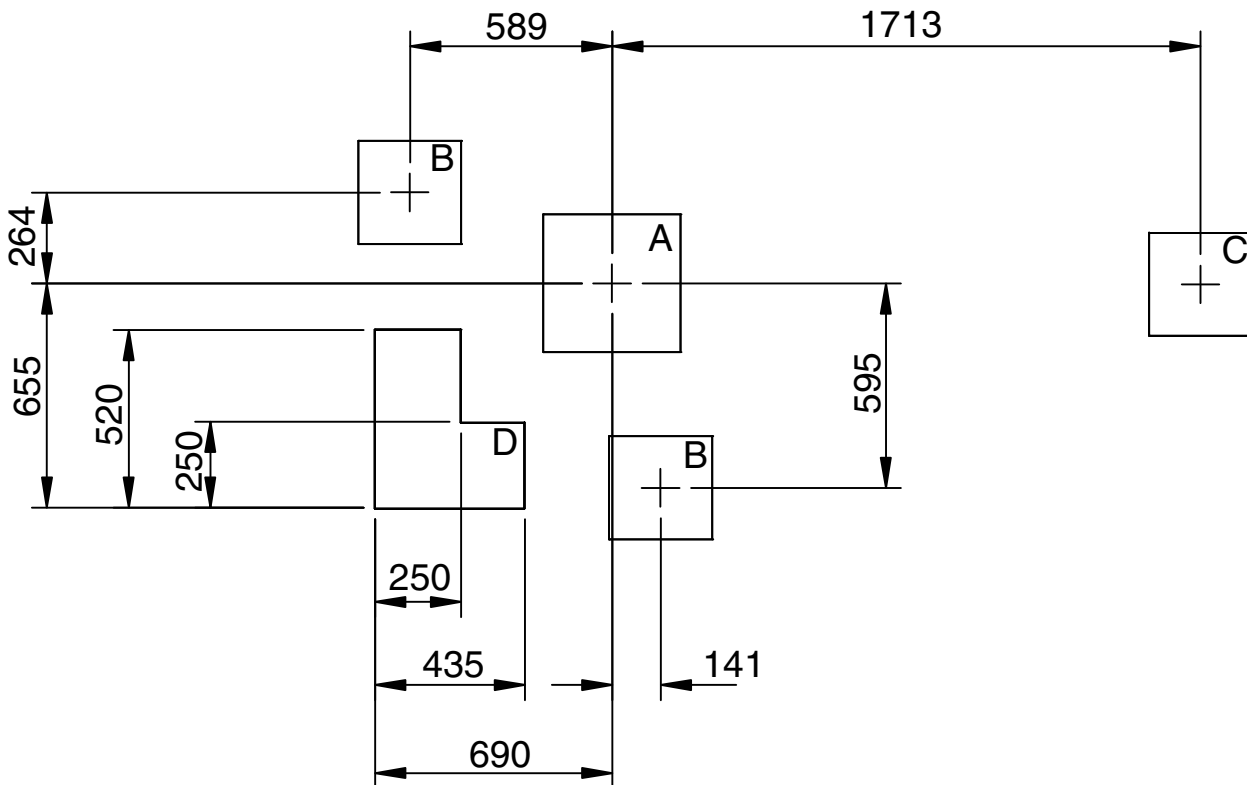

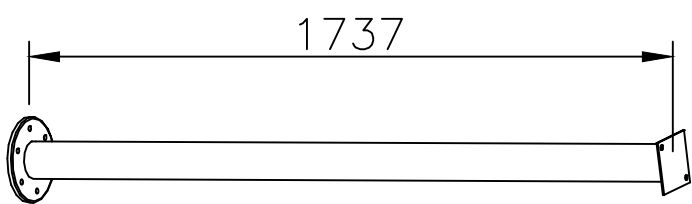
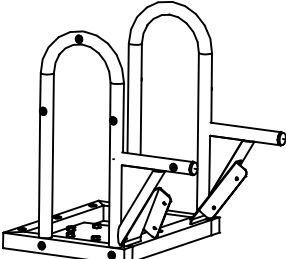
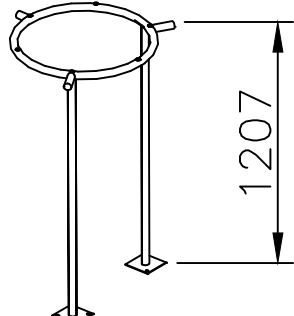
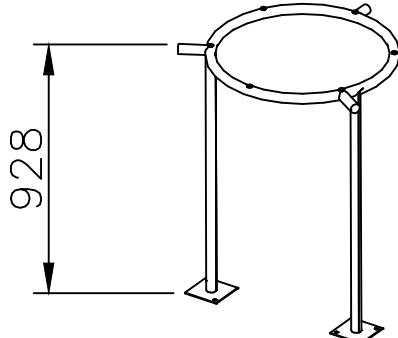
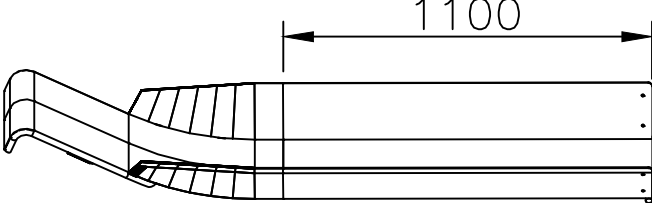
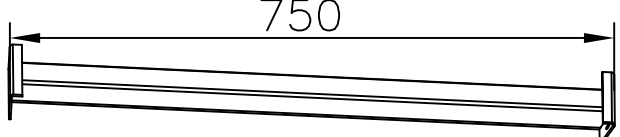

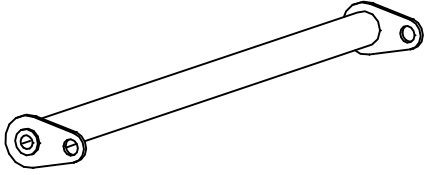
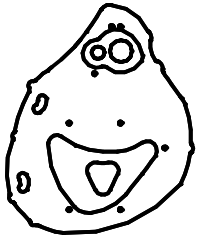
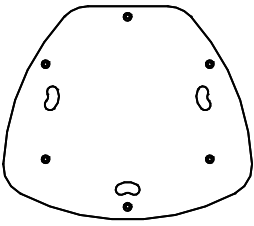
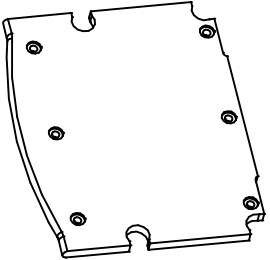
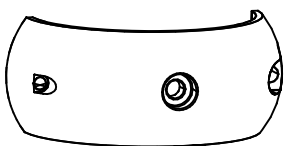
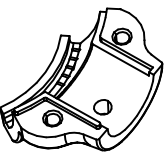
REF		L x W x D (m)
'A'	m	0.40 x 0.40 x 0.95
'B'	m	0.30 x 0.30 x 0.70
'C'	m	0.30 x 0.30 x 0.65
'D'	m	0.52 x 0.435 x 0.70

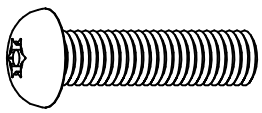
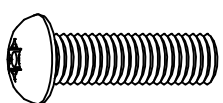

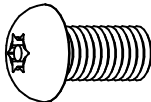
ITEM	REF		X-0900/S	kg
1	55202001		1	21.00
2	55201001		1	18.00
3	55041190		1	12.00
4	55040911		1	10.00
5	45030900		1	21.00
6	70032701		1	4.50

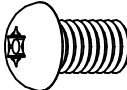
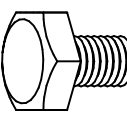
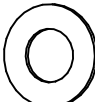
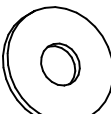
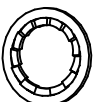
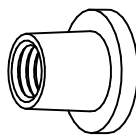
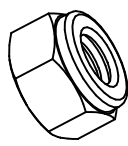
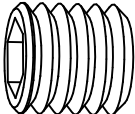
ITEM	REF		X-0900/S	kg
7	55203001		1	1.50
8	55205001		1 PR	16.00
9	55090020		2	8.00
10	55204001		1	3.00
11	55030799		4	0.20
12	55030399		2	0.10
13	55030499		2	0.10
14	10121040	 M10 X 40	14	0.037
15	10121035	 M10 X 35	24	0.032

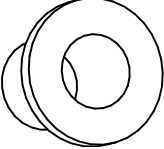
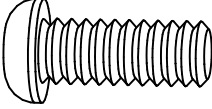
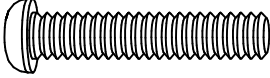
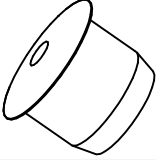
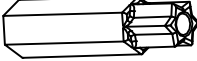
ITEM	REF		X-0900/S	kg
16	10121020	 M10 X 20	2	0.020
17	10120625	 M6 X 25	2	0.011
18	10120610	 M6 X 10	4	0.005
19	10251016	 M10 X 16	2	0.020
20	10291000	 M10 11X21X1	40	0.002
21	10309999	 M10 11X30X2.5	2	0.011
22	10301200	 M12 13X20X1	2	0.002
23	10931000	 M10	2	0.020
24	10260600	 M6	4	0.002
25	14104285	 3/8"UNC X3/8"	2	0.003

ITEM	REF		X-0900/S	kg
26	14104942		2	0.001
27	14104750	 1/4"UNC X5/8"	4	0.005
28	14104749	 1/4"UNC X 1-1/4"	4	0.007
29	19055030		2	0.001
30	10121000	 T45 M10	1	-
31	10120600	 T30 M6	1	-
32	10120500	 T27 1/4"UNC	1	-

# STEP 1

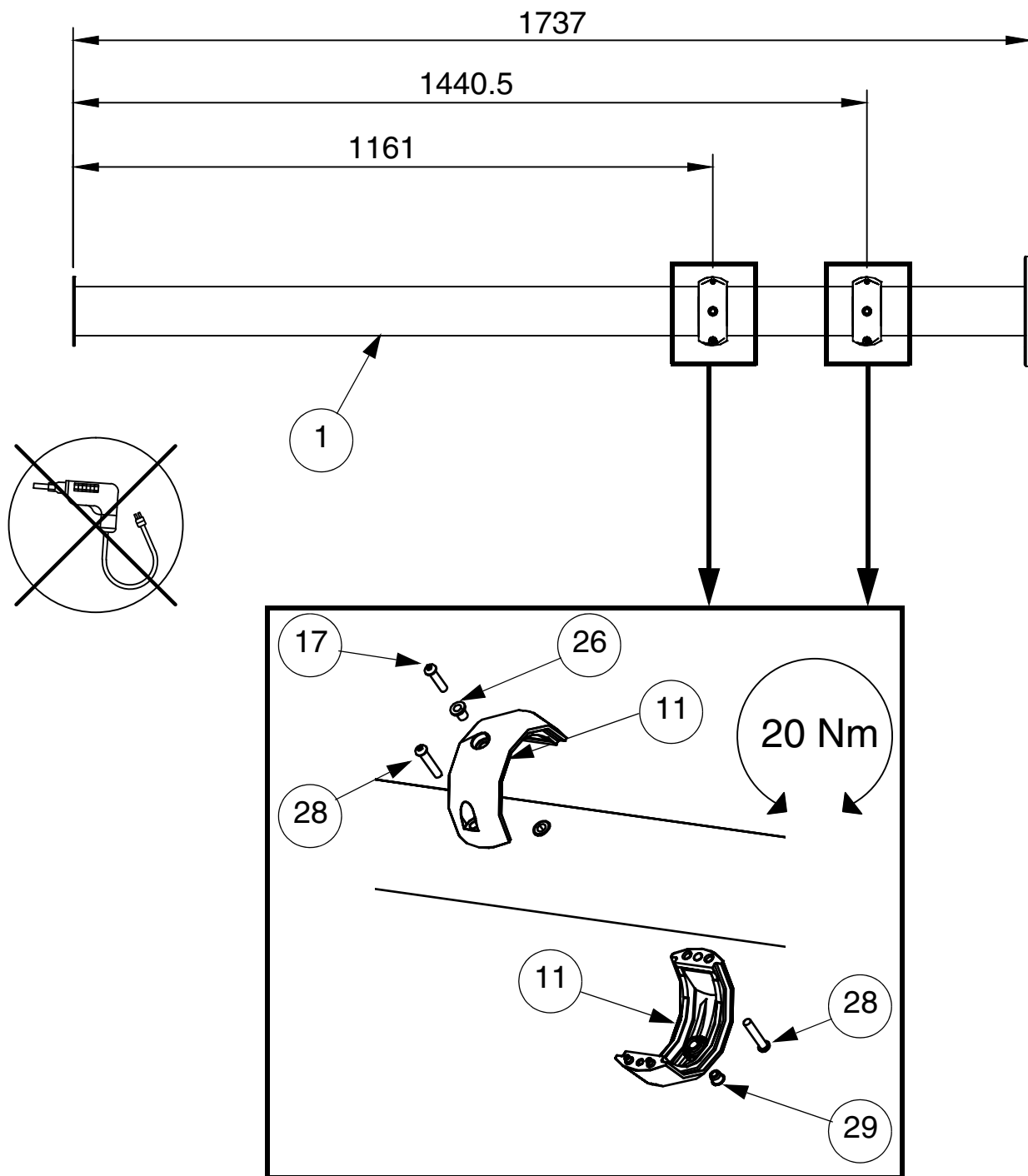

## STEP 2

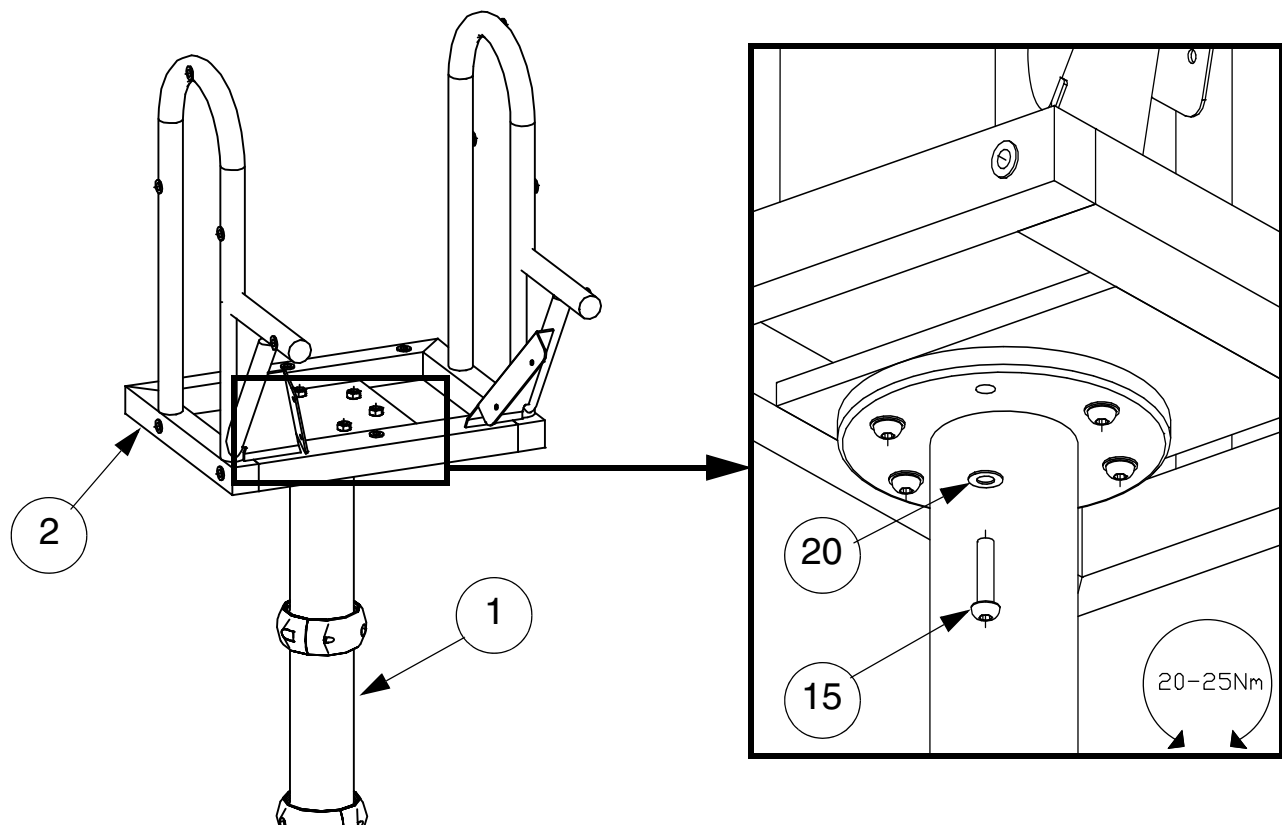

## STEP 3

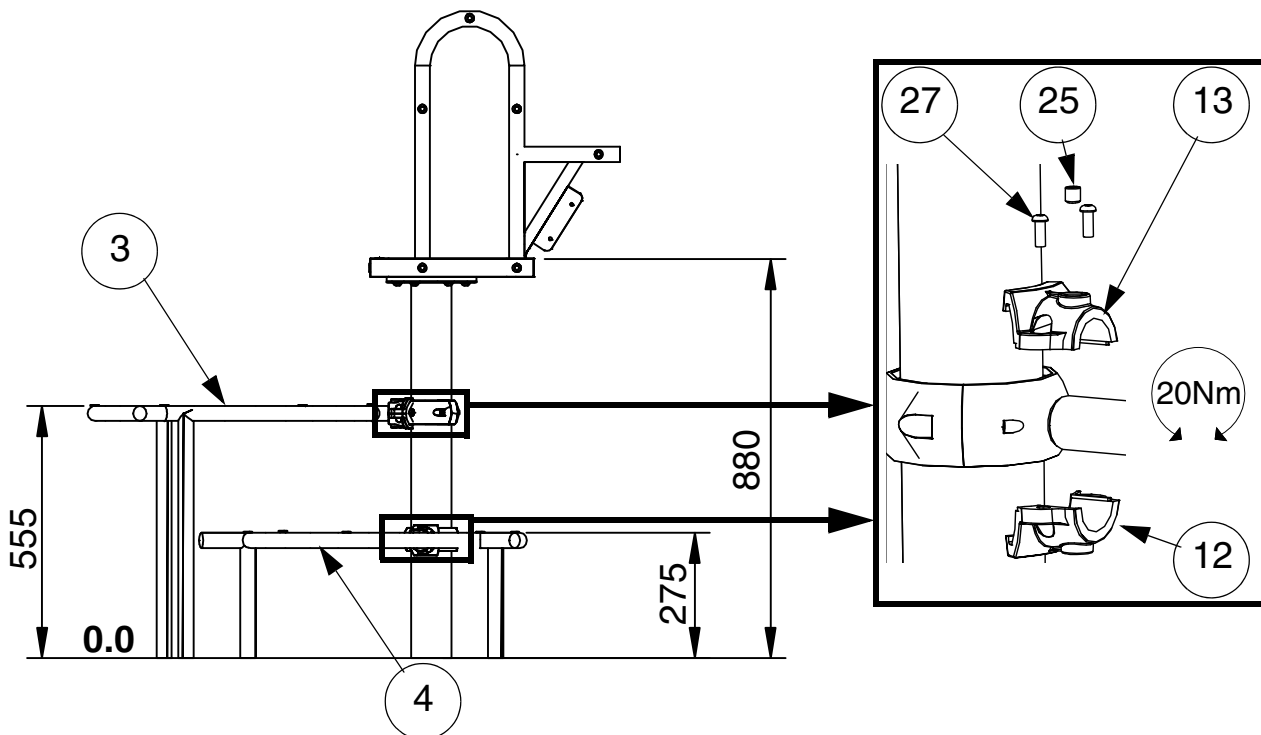

### STEP 4

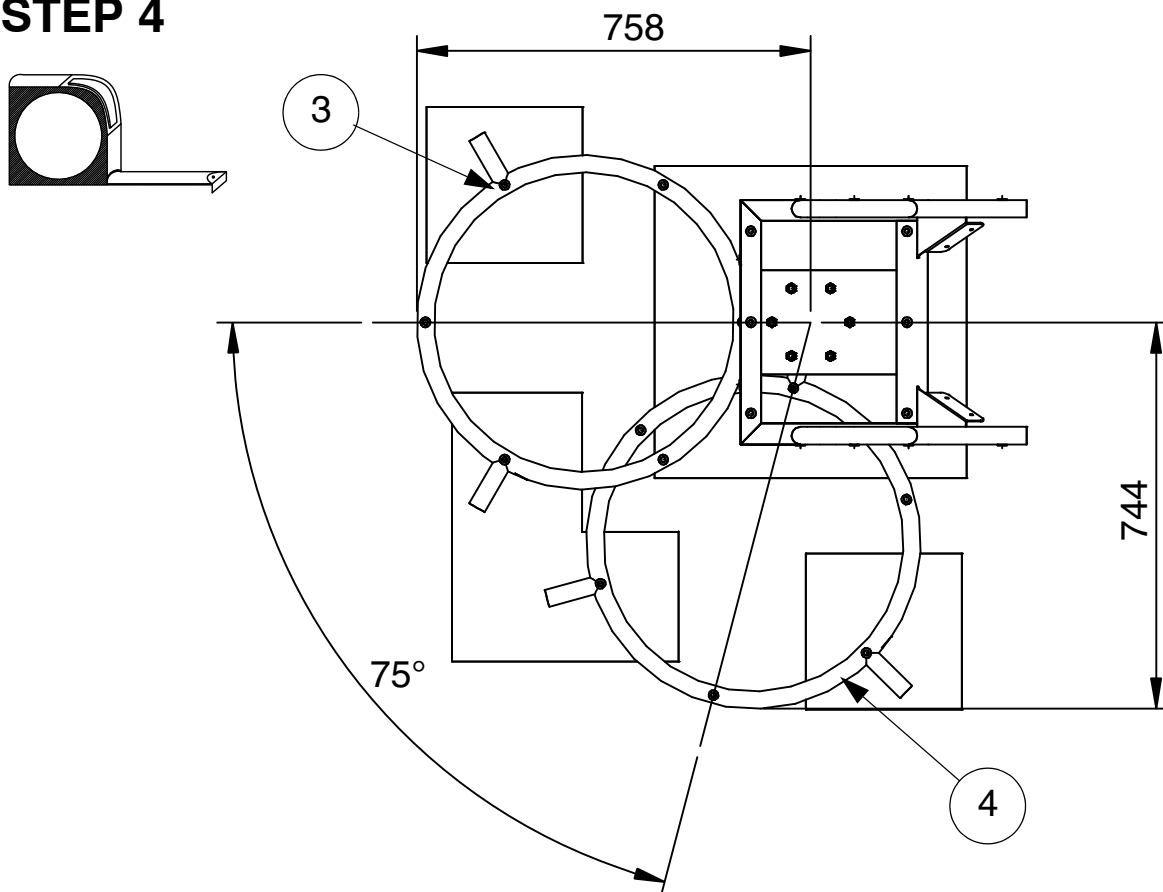

### STEP 5

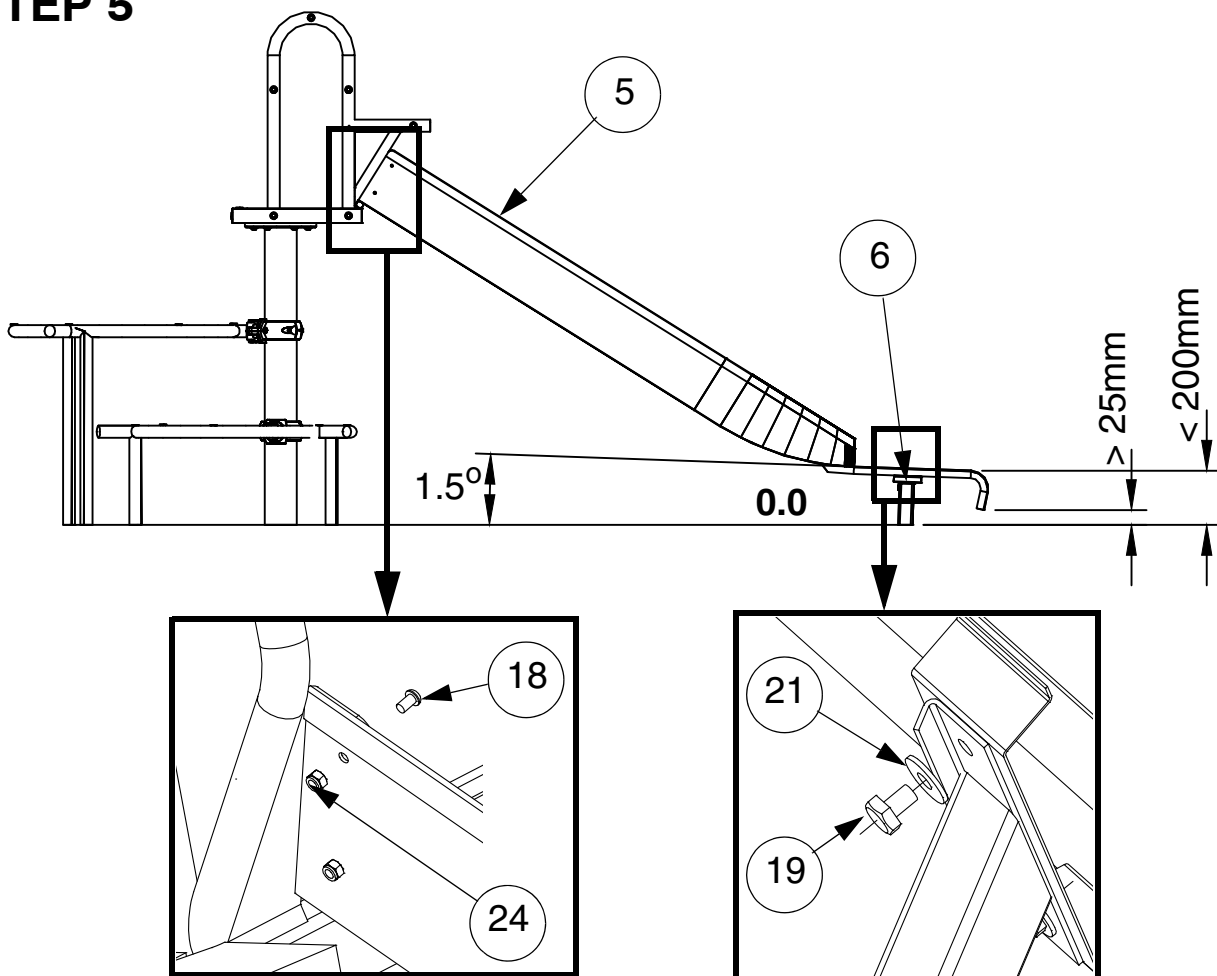

# STEP 6

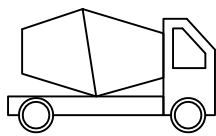
S2 (50mm)
≥C20-25
🕒 7 x 24h
👁️ 101

# STEP 7

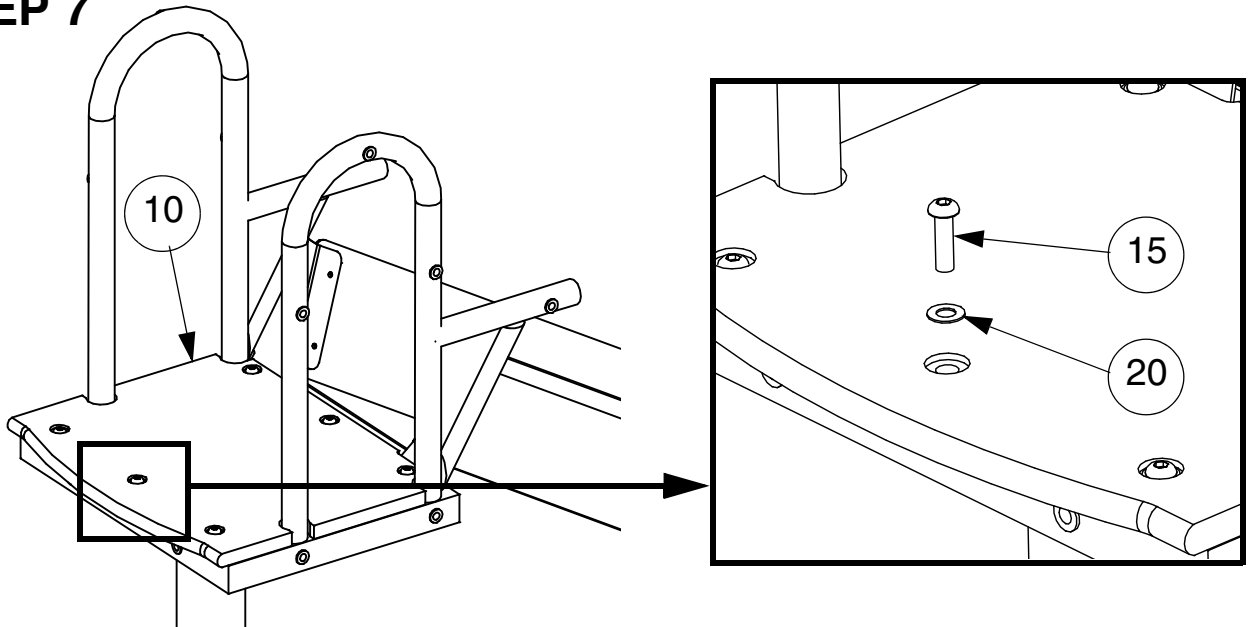

# STEP 8

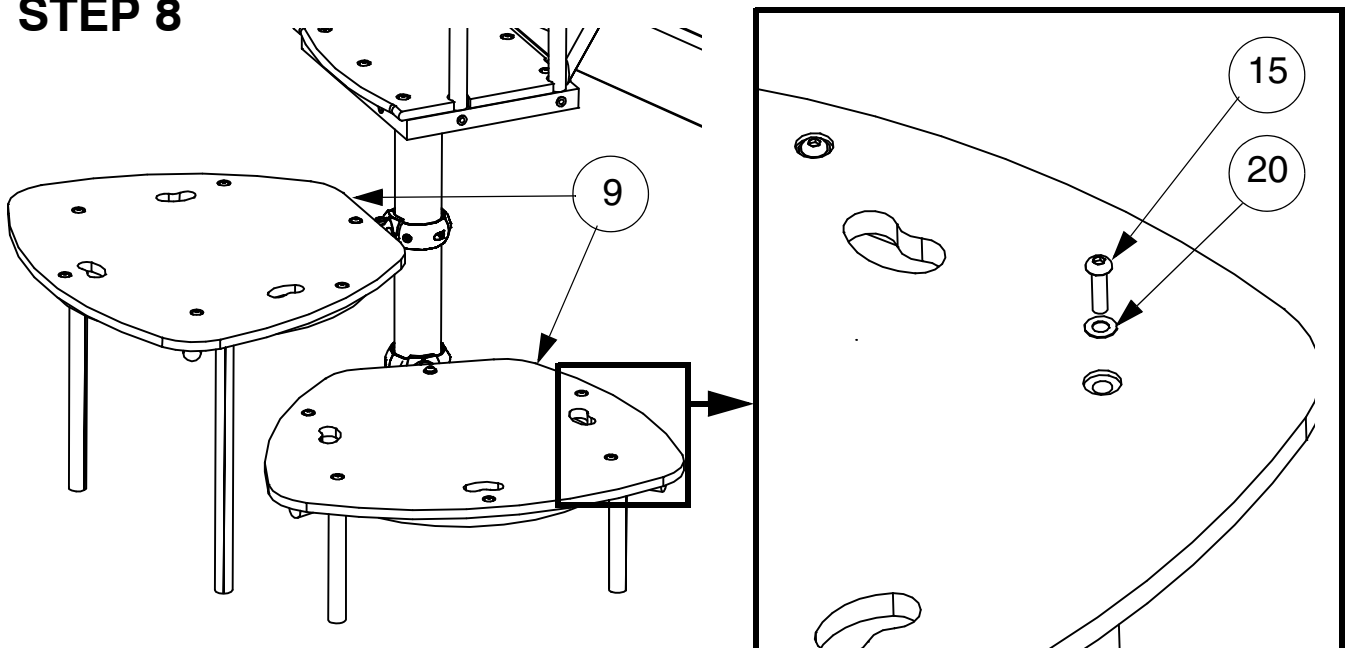

# STEP 9

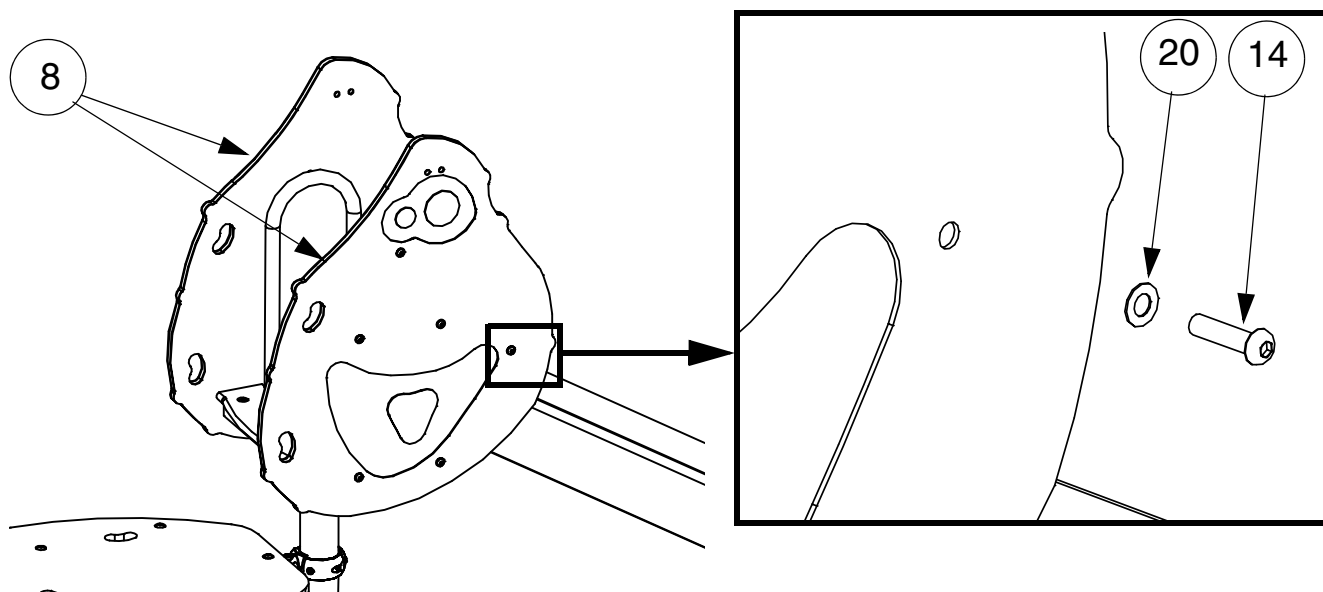

# STEP 10

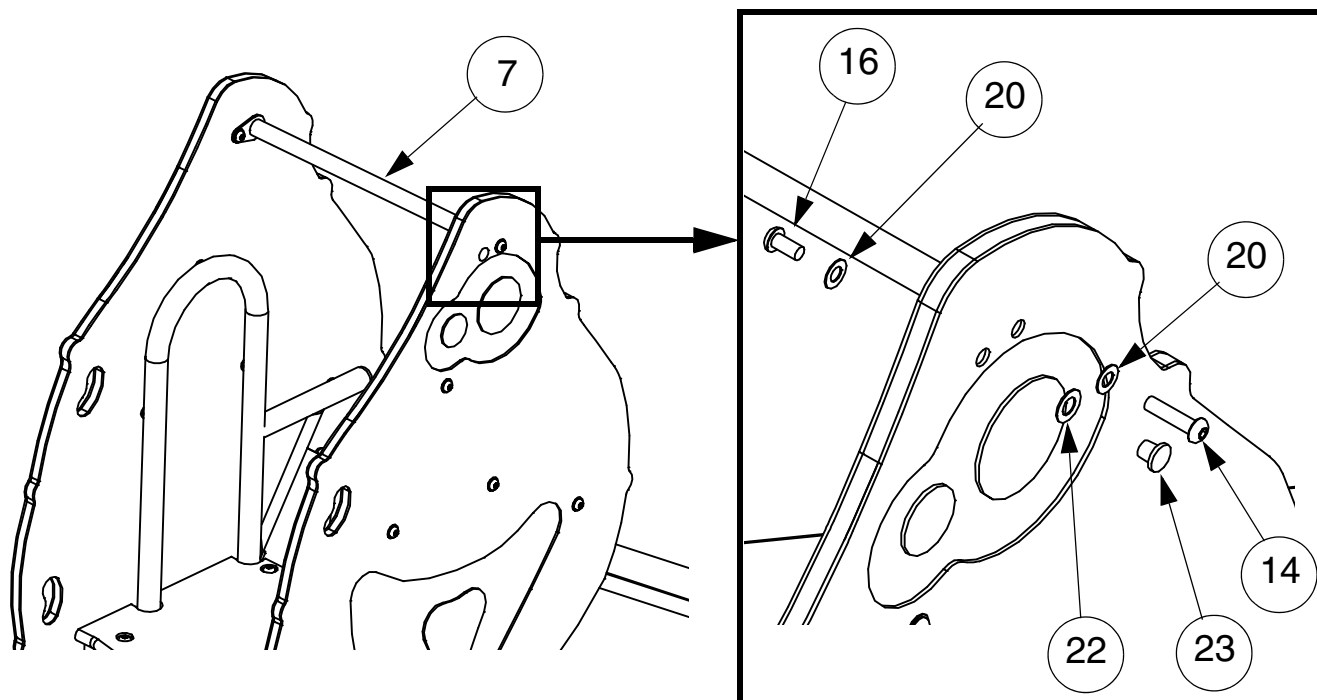

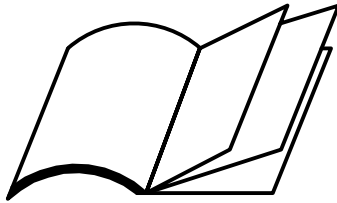

Appendix A:

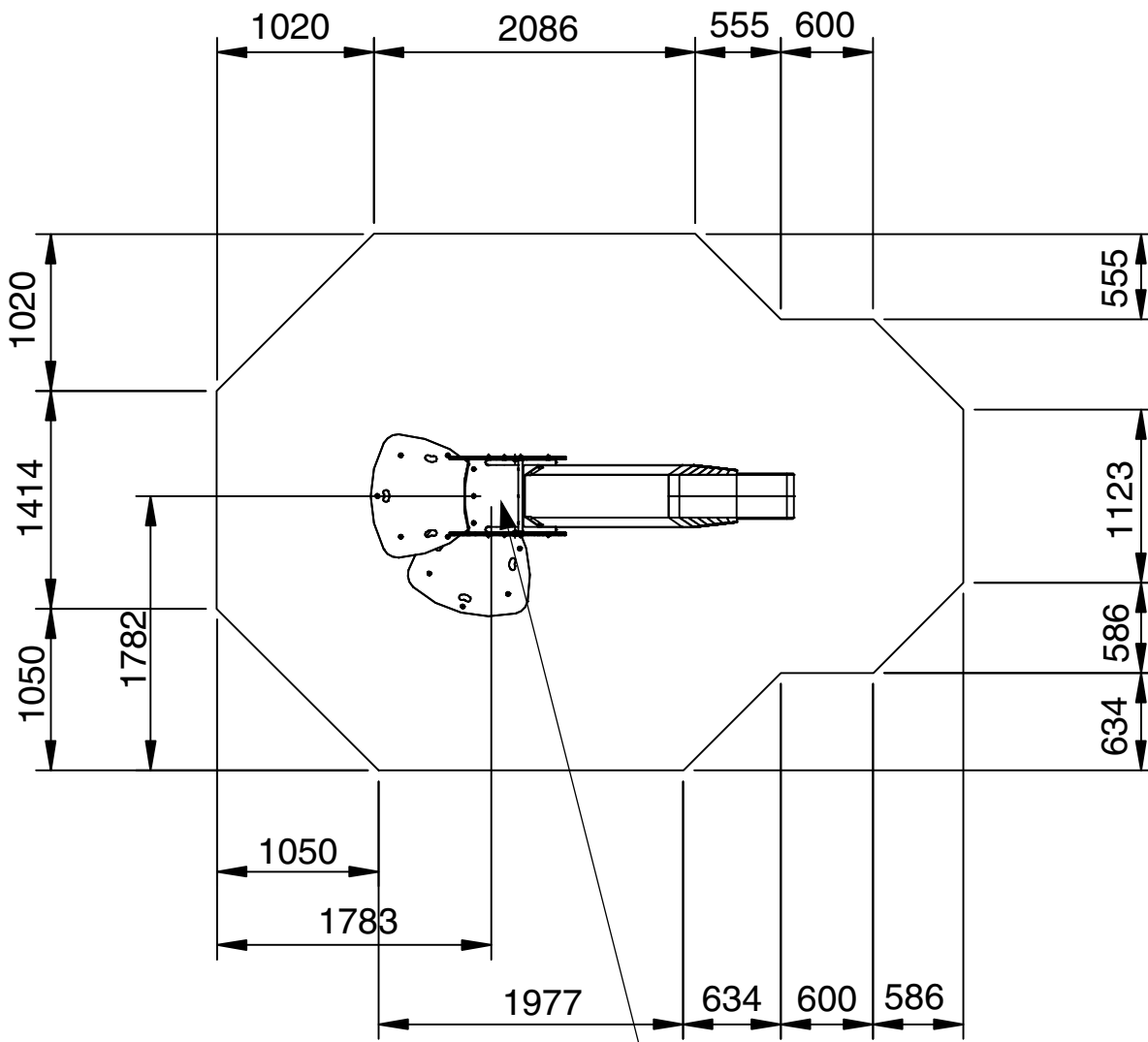

C/L ZINGO SLIDE COLUMN (ITEM 1)

WET POUR AREA

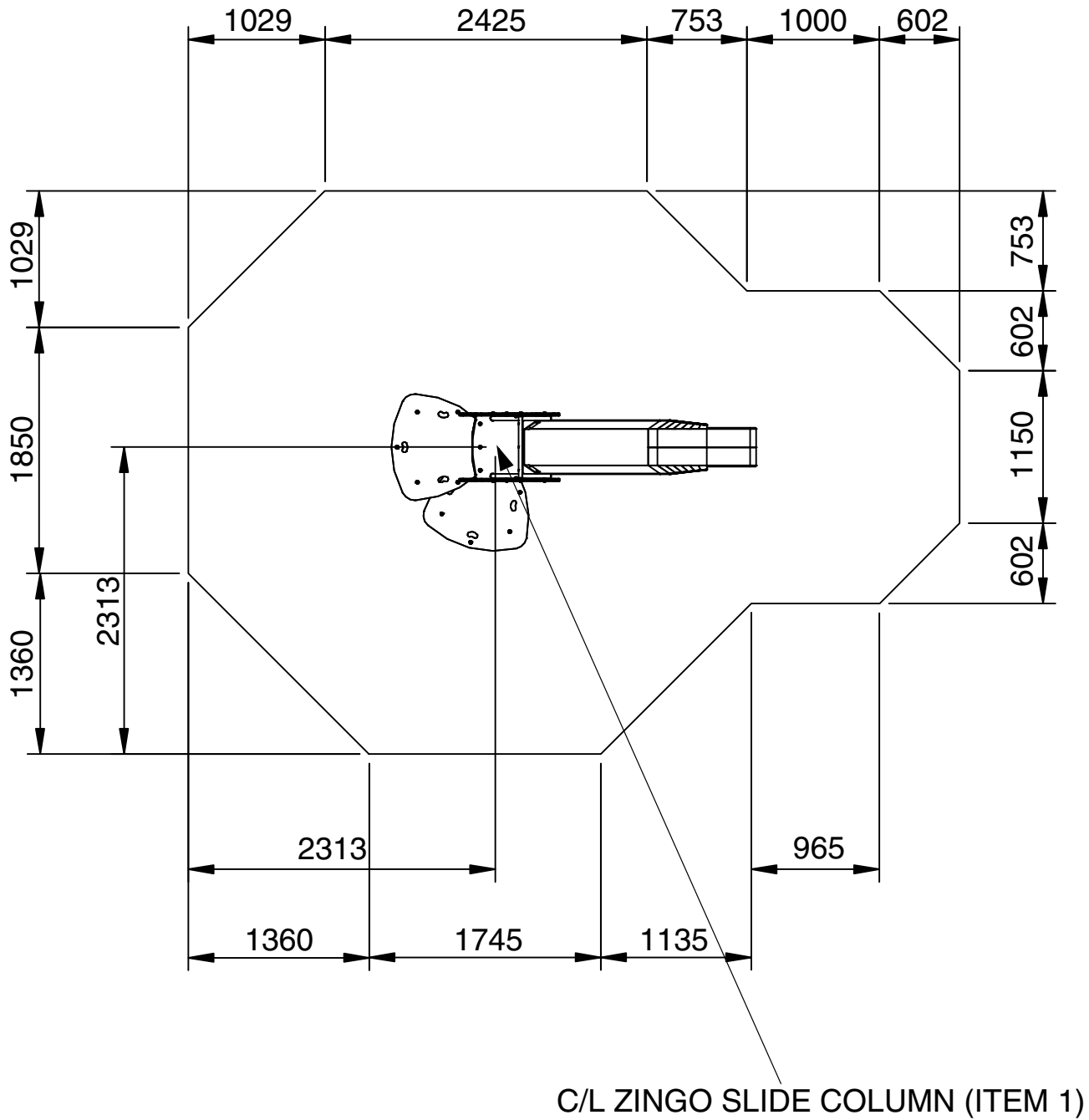

LOOSE FILL AREA

---

## 1 SAFE WORKING PRACTISE

A full risk assessment should be carried out prior to commencing the installation, which will be specific to the site selected. The major risks associated with purely the assembly of this product are highlighted below, which can form part of this overall assessment.

### 1.1 RISKS:

- i) Large parts which could be difficult to lift or handle.
- ii) Structure unstable until concrete footings have fully cured.
- iii) Parts at height that may require working overhead.

### 1.2 CONTROL MEASURES:

- i) Warn the public of the risk of injury, by placing signs and fencing the surrounding area, before commencing installation.
- ii) All staff working on installation to wear suitable PPE including Toe Protective Shoes, Hard hat and Gloves.
- iii) Any staff or other persons on site, not working directly on the installation, to be kept away from the installation.
- iv) Ensure adequate personal and equipment are on site to handle and support the structure whilst it is being assembled.

## 2 SPECIFICATIONS

SMP Playgrounds Ltd recommends an effective *Impact Absorbing Surface tested to EN1177 & BS7188* beneath this play equipment. Refer to manufacturers instructions for details of installation. The surface should have a Critical Fall Height greater than the Maximum Free Fall Height of the equipment.

Constructional Space is the approximate working area required to lay out and assemble the equipment.

For the safe operation of this equipment it must be installed on horizontal ground with the required minimum space.

The concrete foundations indicated are for average ground. Care should be taken concerning abnormal conditions.

If a loose fill surface is selected for this item it will require a very high level of maintenance to ensure a sufficient thickness is in place at all times to provide 'critical fall height' protection.

## 3 PREPARATION

All equipment assembly and fixing must conform to EN1176.

**Tools / ancillary equipment:** 10m tape measure, Spirit level, Torx tools (Supplied with unit), Adjustable set square, 3/16" Allen key, Torque wrench

### 3.1 ESTABLISH ORIENTATION

- i) See Specifications for equipments 'Minimum space'.
- ii) Measure out the site to ensure the space required fits into the allotted area, it is horizontal and free from trip points or other obstructions.
- iii) Ensure the equipment is to be provided with an effective Impact Absorbing Surface which has a tested critical fall height rating greater than the maximum Free Fall Height of the equipment.

### 3.2 MARK OUT HOLES

Consult SMP layout drawing for structure position on site.

See **page 4** for concrete foundation size.

**NOTE:** This is a minimum guide only.

### 3.3 ESTABLISH DATUM LEVEL

- i) If a rubber tiled Impact Absorbing surface is to be laid, see separate instructions (base may incorporate up to 2% falls etc).
- ii) If equipment is to sit in loose fill or wet pour rubber surfaces allowances will need to be made for its recommended thickness. Generally it is recommended that loose fill surfaces are installed to a minimum depth of 300mm, however, with certain loose fill materials a greater depth may be required. This will need to be determined by allowing 100mm for the dispersal in addition to the thickness required for the particular Free Fall Height. The foundation illustrated will allow for a thickness up to 300mm.

### PRE-INSTALLATION INSPECTION

Inspect all parts for damage (that may have occurred during transportation & storage). Finish Coatings, if found to be damaged these should be made good before erection (Refer to maintenance instructions). Any damaged or missing parts must be replaced.

## 4 INSTALLATION

- 1) Refer to site layout for position and orientation of product, then mark the outline of the position of the footings with e.g. spray or chalk. Excavate the holes.
- 2) Assemble to Zingo Slide Column (item 1), 2 off Clamp Rings (half) (item 11) at the pre-inserted hole position for the 300 & 600 Deck Clamp Height. **STEP 1.**
  - i) Position Clamp Ring (half) (item 11) on to leg with fixing hole aligned with appropriate M6 insert.
  - ii) Place 1/4" Screw Insulator (item 26) into hole and then screw the Resistorx bolt M6 x 25 (item 17) into M6 insert to retain and locate the Clamp Ring (half). (Do not over tighten).
  - i) Position the other Clamp Ring (half) (item 11) and assemble to leg using 2 off 1/4" x 1-1/4" BHCS fixings (item 28). Fully tighten bolts to a maximum torque setting of 20Nm.
  - ii) Into unused fixing hole insert white plastic plug (item 29).
- 3) Attach Deck Frame (item 2) to the flange of the Zingo Slide Column (item 1) using 6 off M10 x 35 Resistorx bolts (item 15) with M10 Washers (item 20). Fully tighten bolts to a torque setting of 20-25Nm. **STEP 2.**
- 4) Assemble Platform Mounting Frame - Low (item 4) and Platform Mounting Frame - High (item 3) to Clamp Rings (half) (item 11) at 300 Deck Clamp Height and 600 Deck Clamp Height radially positioned as shown. Each frame is held between a Bar Socket Top (item 13) and a Bar Socket Bottom (item 12) using BHCS Fixings (item 27). **STEP 3**
  - i) Align the tapped hole in the Bar Socket Top with the hole in the top of the unit fixing rail and secure the sockets together using the 1/4" x 5/8" BHCS fixings (item 27).
  - ii) Tighten the BHCS fixings up equally to ensure that the Top & Bottom Bar Sockets pull up square and grip the unit fixing rail evenly.
  - iii) When the unit fixing rail is in the correct position with the legs square and plumb tighten fastenings to a maximum torque setting of 20Nm.
  - iv) Once clamp is fully tightened lock each Bar Socket Top to unit fixing rail by screwing into the tapped hole a 3/8" x 3/8" Set Screw (item 25) for Bar Socket Top (item 13).
  - v) Shim under legs of frames ensuring that they are plumb and square and orientated correctly with the welded F.S.L. mark at the correct level.
- 5) Assemble Slide Foot 750 (item 6) to underside of Slide (item 5) and secure using 2 off M10 x 16 Hex. Bolt (item 19) and Heavy Duty Washers (item 21). **STEP 5.**
- 6) Offer Slide (item 5) up to Deck Frame (item 2) ensuring the top of the slide rests on the cross member. The walls of the slide must be positioned outside of the gussets on the entry frame. Secure the slide to the gussets using 2 off M6 x 10 Resistorx bolts (item 18) and M6 Nyloc nuts (item 24). The Resistorx bolts heads must be on the inside of the slide. **STEP 5.**
- 7) Shim under the slide legs to set the slide plumb and square adjust the slide exit to the required height.

**NOTE:** The slide runout should taper towards the ground at a angle of 1.5° max. to allow a watershed.

**NOTE:** It is very important to check the slide run out section does **not** hold water after installation. It is recommended that an actual test be carried out, on site, prior to concreting the slide into its final position. Should any deformation to the run out section have occurred during transportation and storage this must be corrected prior to final installation.

**NOTE:** Check that the completed structure has been positioned in the correct place, that it is plumb and square and all the fasteners are fully tightened to the correct torque settings. Also ensure that the structure is propped safely so that it may be left for the concrete foundations to cure.

- 8) Fill the holes with concrete to the required level, taking into account any Impact Absorbing Surfacing requirements. Ensure that a full volume of concrete is used. The top of the concrete should gradually (1:100) slope down & outwards locally from the equipment upstand to the required level to form a watershed. **STEP 6**

Concrete mix is recommended at:  
1 part cement;  
2 parts sand;  
4 parts aggregate;  
by volume with 20mm aggregate  
(20 N/mm<sup>2</sup> min. compressive strength)

- 9) Keep installation off limits to the public until the concrete has completely cured. (Recommended initial curing time is 48 hours).
- 10) Position Deck Poly (item 10) onto Deck frame as shown and secure using off M10 x 35 Resistorx bolts (item 15) and M10 Washer (item 20) in positions shown. **STEP 7**
- i) Ensure that flat end in the deck for the mounting of the slide is positioned at the correct orientation.
- 11) Assemble Platforms (item 9) to Platform Mounting Frames using 6 off M10 x 35 Resistorx bolts (item 15) and M10 washers (item 20). **STEP 8**
- 12) Assemble the Slide Poly pair (item 8) to the Deck Frame (item 2) using 12 off M10 x 40 Resistorx bolts (item 14) with M10 Washers on each panel. **STEP 9**

**NOTE:** Ensure that panels are mounted with the graphics facing in the correct direction.

- 13) Attach Tie Bar (item 7) to the pair of Slide Poly Panels (item 8) in position as shown using 2 off M10 x 40 Resistorx bolts (item 14) and M10 Washers (item 20). **STEP 10**
- 14) Place 2 off M10 Tee Nut (item 23) with M12 Shockproof washer (item 22) into hole on the outer side of Slide Poly (item 8). Secure from the inner side of the Slide Poly (item 8) using 2 off M10 x 20 Resistorx bolts (item 16) and M10 Washers (item 20). **STEP 10**

---

## 5 POST INSTALLATION INSPECTION

CHECK	TICK
1 All fixings are tightened to there appropriate torque settings and have no protruding sharp edges.	<input checked="" type="checkbox"/>
2 Paint work and polyethylene panels are not damaged. (Any making good should be carried out using the procedure in the Inspection and Maintenance instructions).	<input type="checkbox"/>
3 Concrete foundations are secure.	<input type="checkbox"/>
4 Concrete has a water shed away from legs.	<input type="checkbox"/>
5 Adequate provision of impact absorbing surfacing and no trip points within the minimum space.	<input type="checkbox"/>
6 Ensure all unused fixing holes in clamps have the correct plastic plug fitted.	<input type="checkbox"/>
7 Site is clear of all tools and rubbish.	<input type="checkbox"/>
8 Remove any warning signs.	<input type="checkbox"/>