



Bringing together leading brands in the play industry

## INSTALLATION INSTRUCTIONS

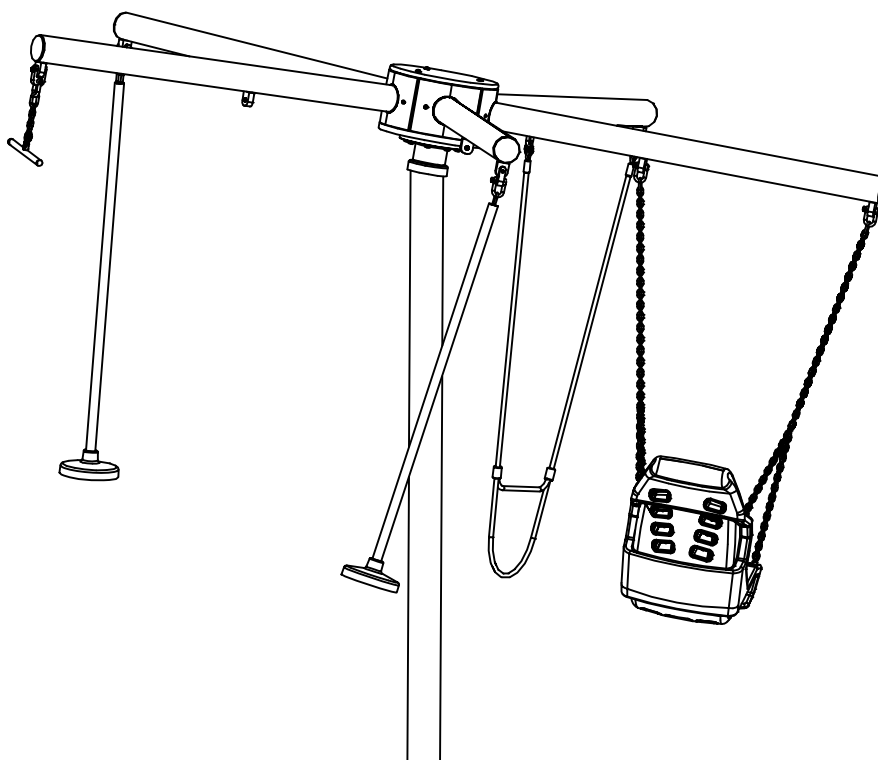

### TITAN CAROUSEL

### CAR-TAN, CAR-TAN(N)

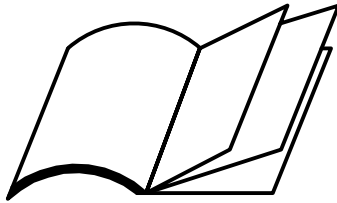

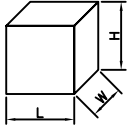
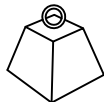
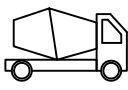
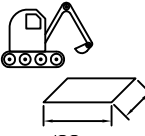
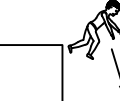

**Section 1:**

	 LxWxH (m)	 kg	 m <sup>3</sup>	 m	 ≥EN1176	 x 2 = T
<b>CAR-TAN</b>	Ø3.900 x 3.12	397.0	2.05	12.00 x 12.00	1.50m	T = 32h

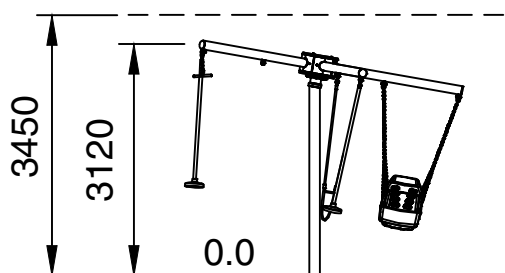
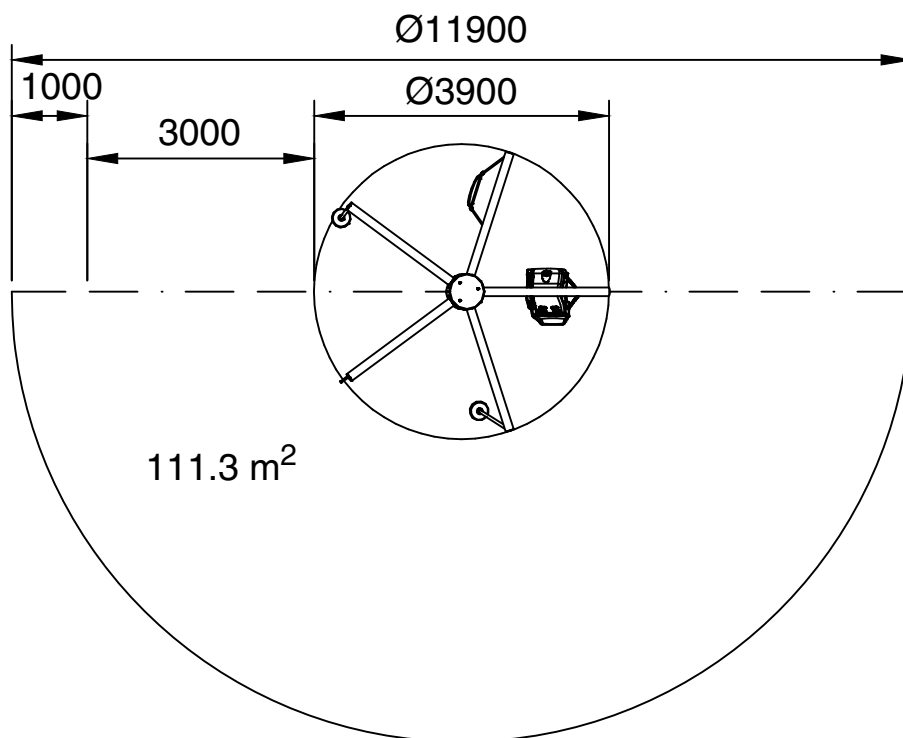

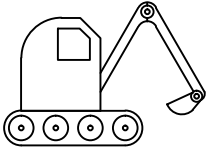

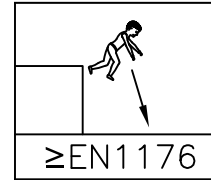

 101/144



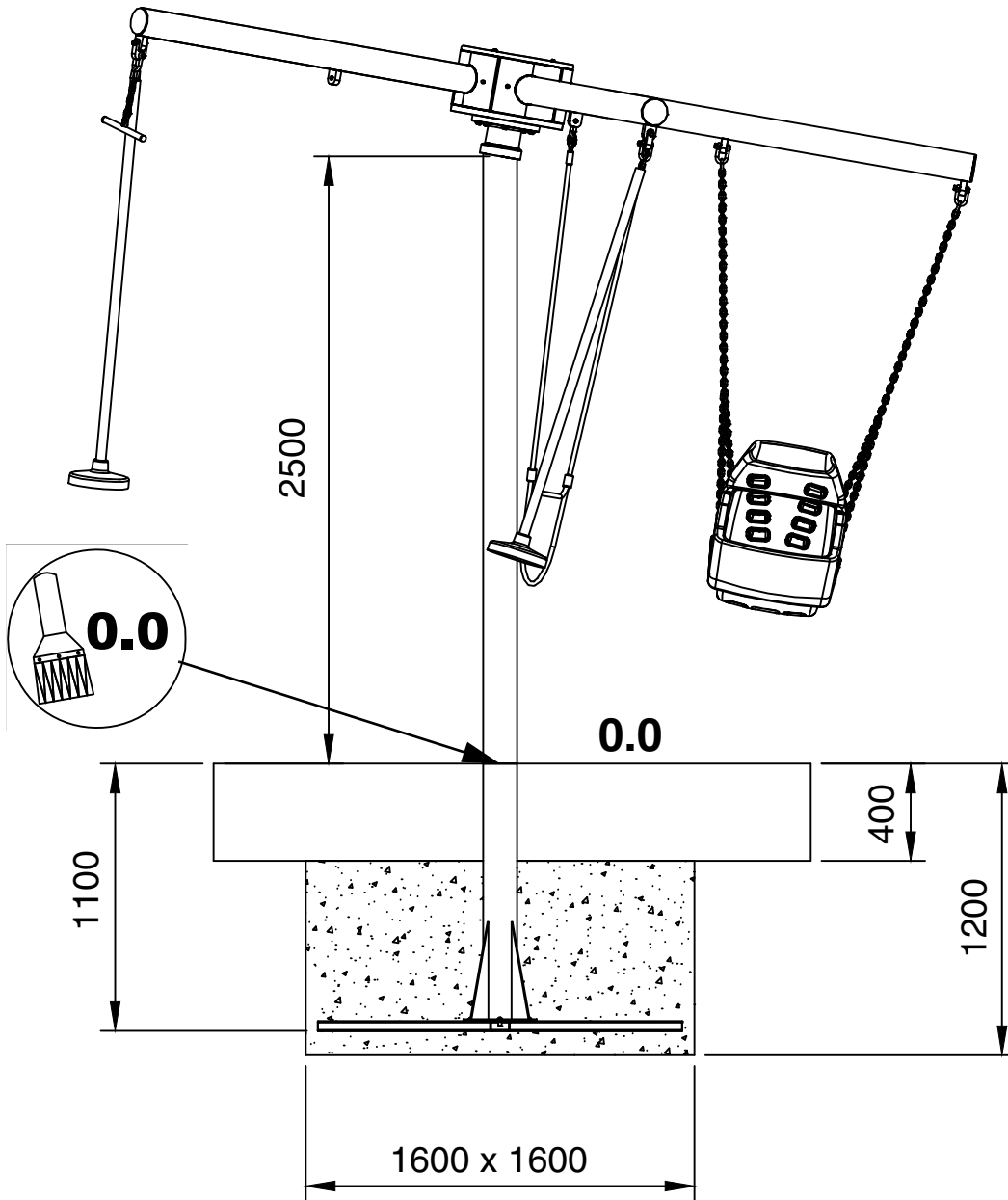

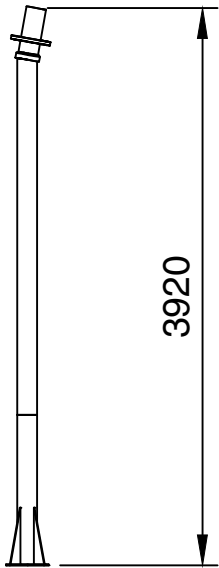
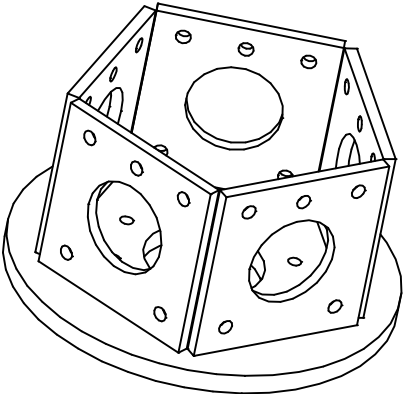
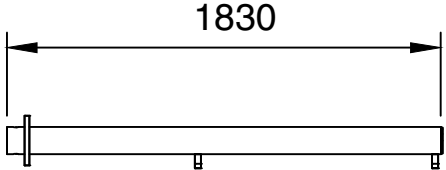
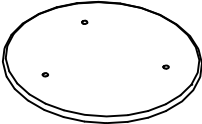
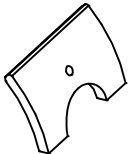
1.5 m

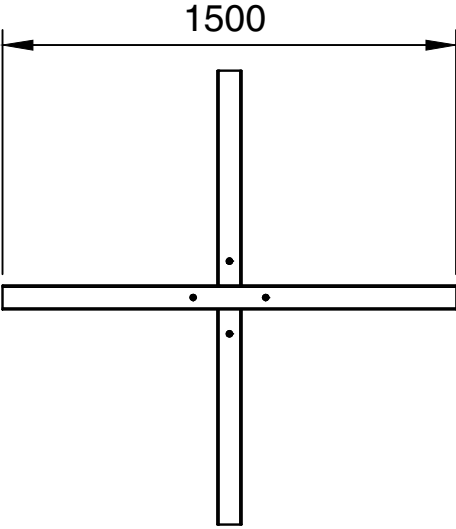
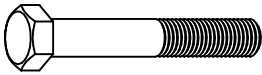
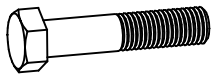
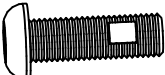

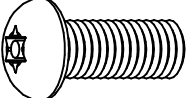
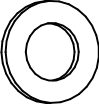
ITEM	REF	CAR-TAN/CAR-TAN(N)	QTY	kg
1.1	71200100		1	139.00
1.2	71200320		1	52.00
1.3	71200110		5	30.00
1.4	71200500		1	3.50
1.5	71200530		10	0.20

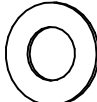
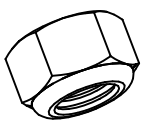
ITEM	REF	CAR-TAN/CAR-TAN(N)	QTY	kg
1.6	71200315		1	16.00
1.7	10252130	 <p data-bbox="724 913 986 965">M20 X 130</p>	5	0.362
1.8	10251675	 <p data-bbox="735 1104 975 1155">M16 X 75</p>	25	0.146
1.9	10141650	 <p data-bbox="735 1290 975 1341">M16 X 50</p>	8	0.060
1.10	10121035	 <p data-bbox="746 1491 986 1543">M10 X 35</p>	3	0.032
1.11	10121025	 <p data-bbox="746 1686 986 1738">M10 X 25</p>	4	0.024
1.12	10291600	 <p data-bbox="724 1888 970 1939">M16 17X30X3</p>	58	0.004

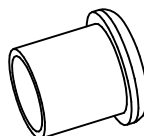
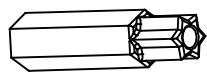
ITEM	REF	CAR-TAN/CAR-TAN(N)	QTY	kg
1.13	10291000	 M10 11X21X1	7	0.002
1.14	10321600	 M16	25	0.030
1.15	10050540	 TECH 5 X 40	10	0.007
1.16	19055090		10	0.032
1.17	10121000	 T45 M10	1	-

# STEP 1

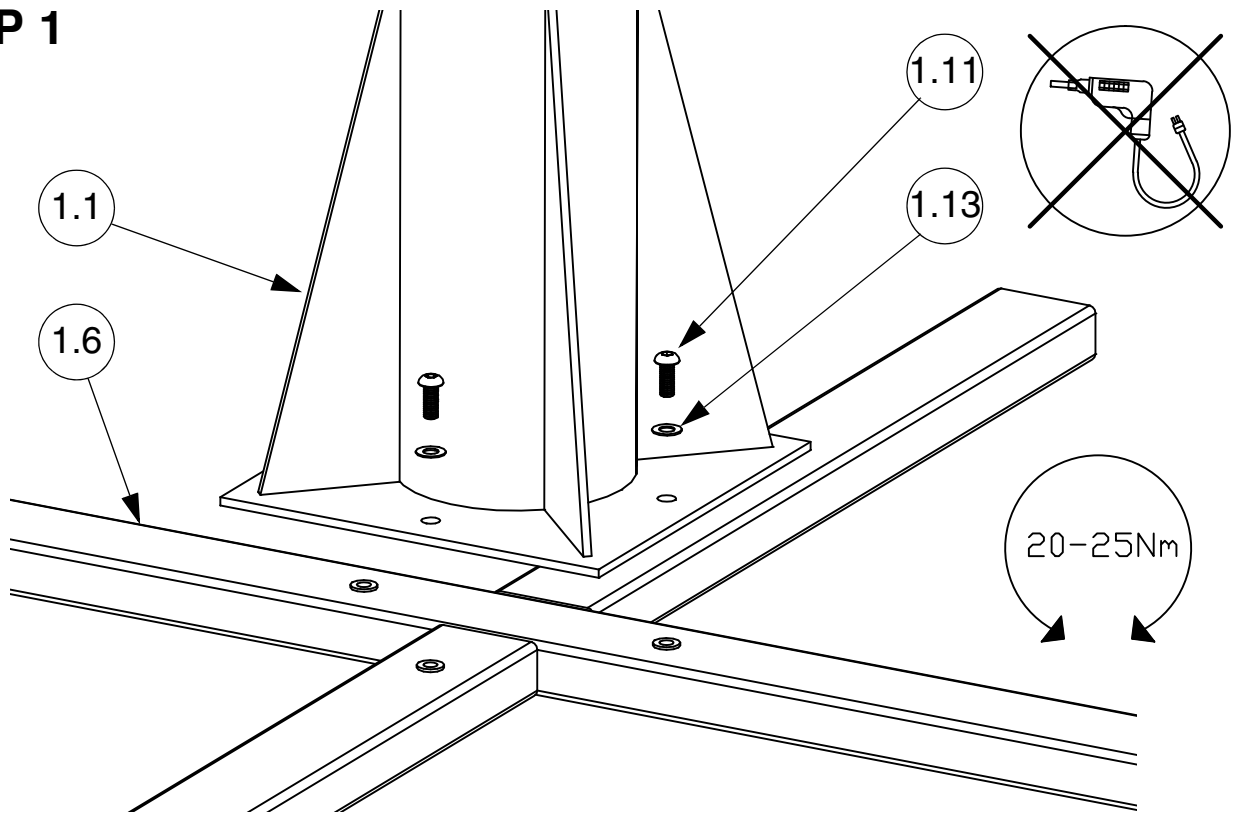

# STEP 2

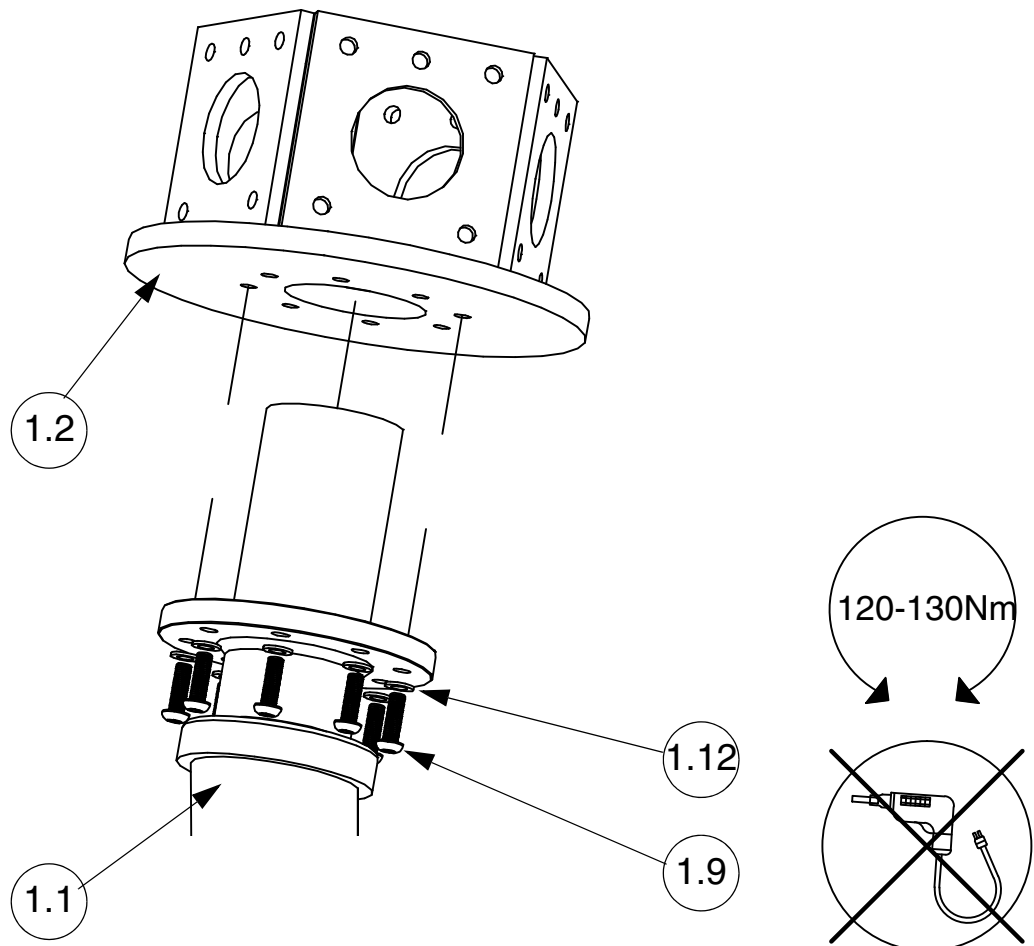

### STEP 3A

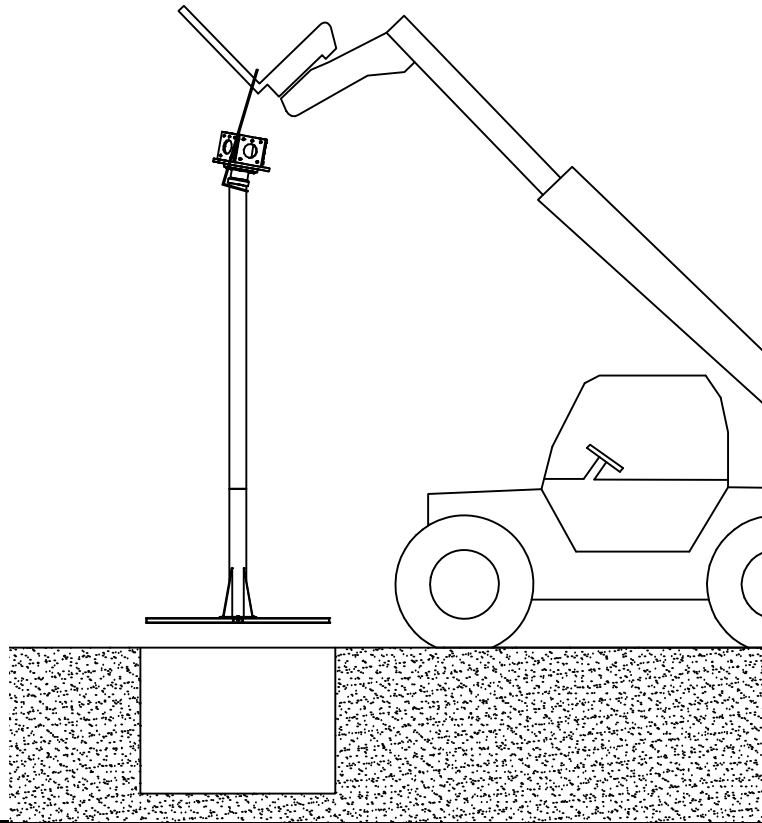

### STEP 3B

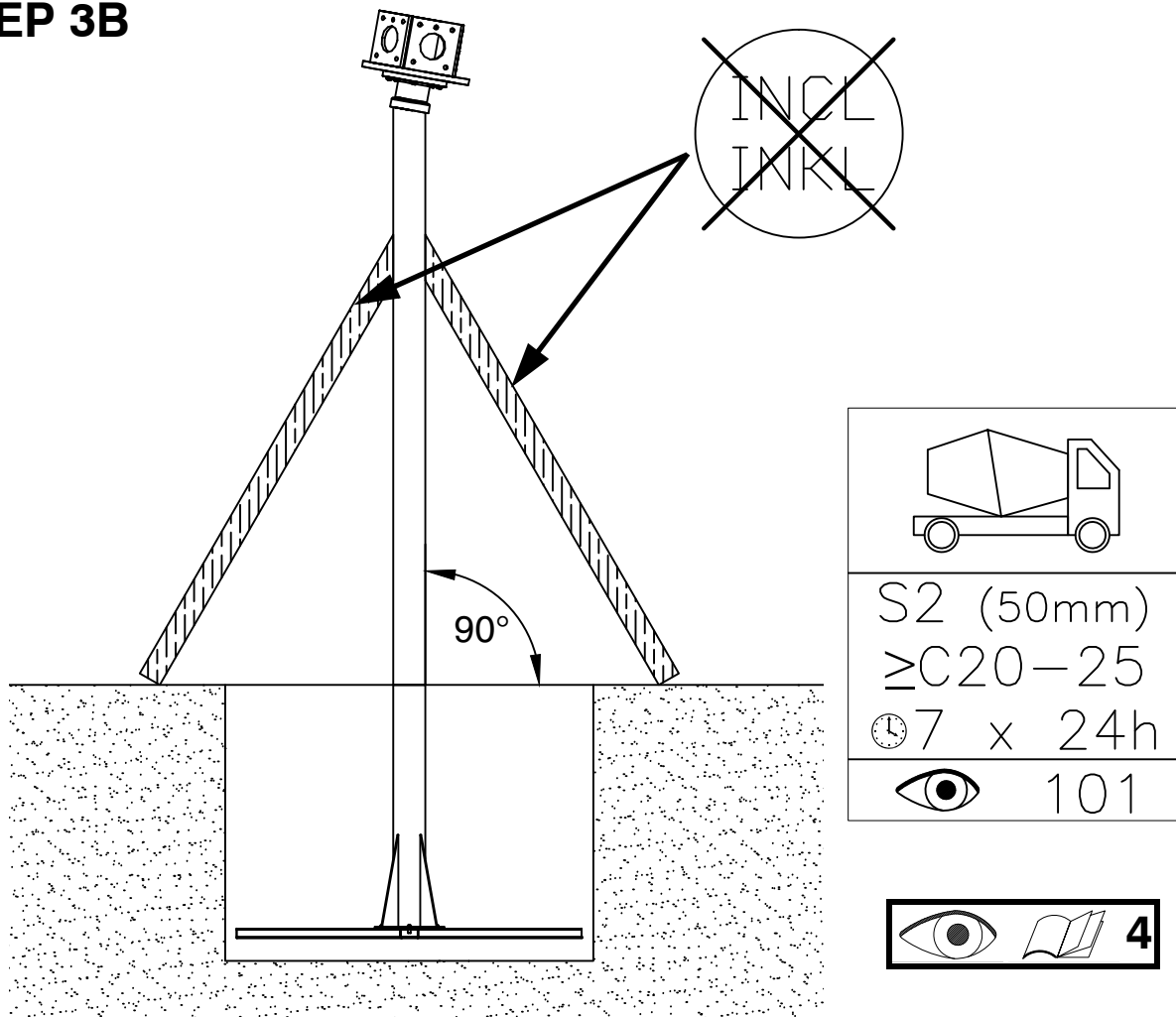

# STEP 4

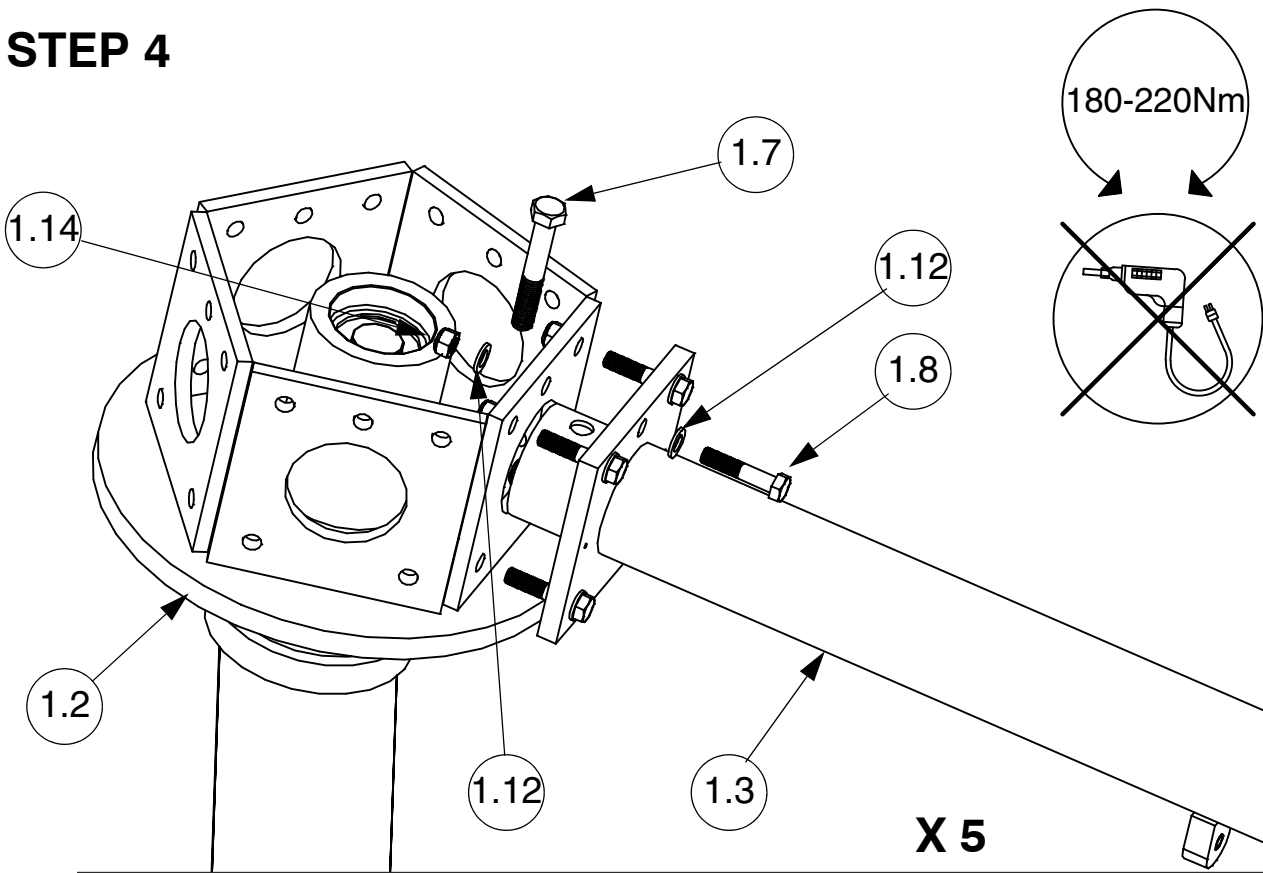

# STEP 5

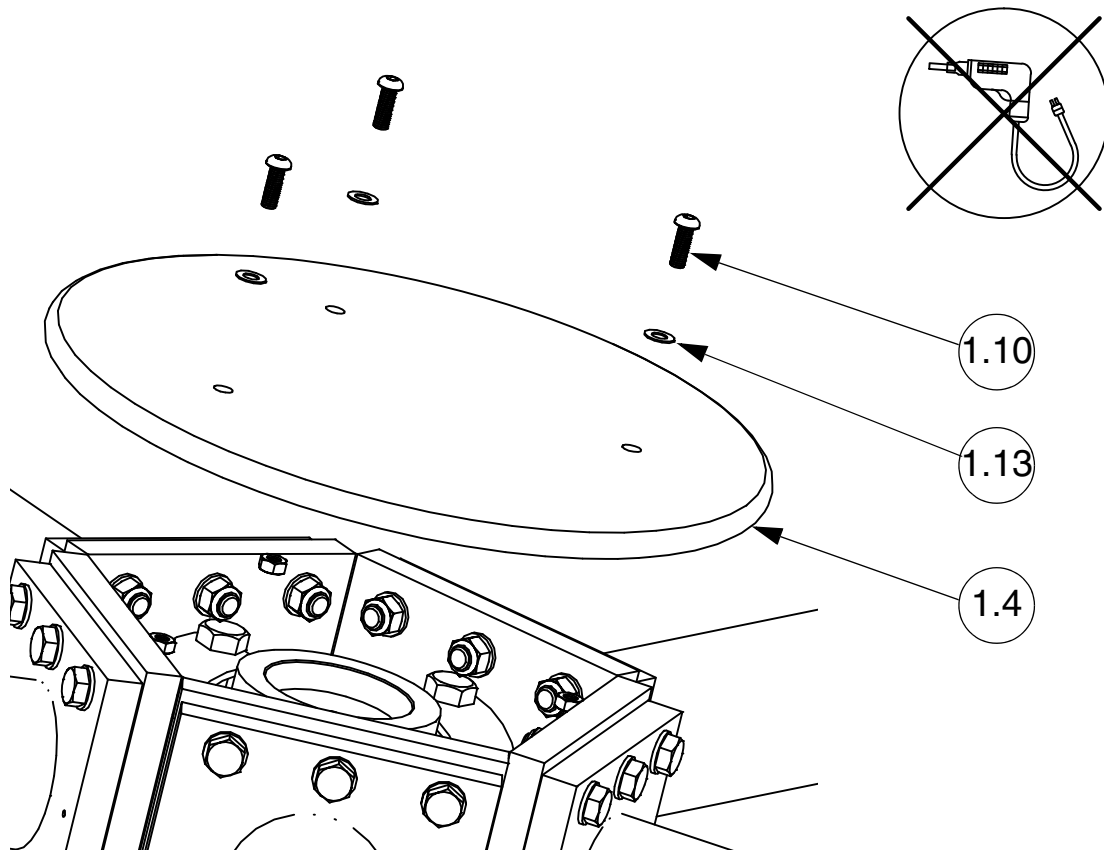

# STEP 6

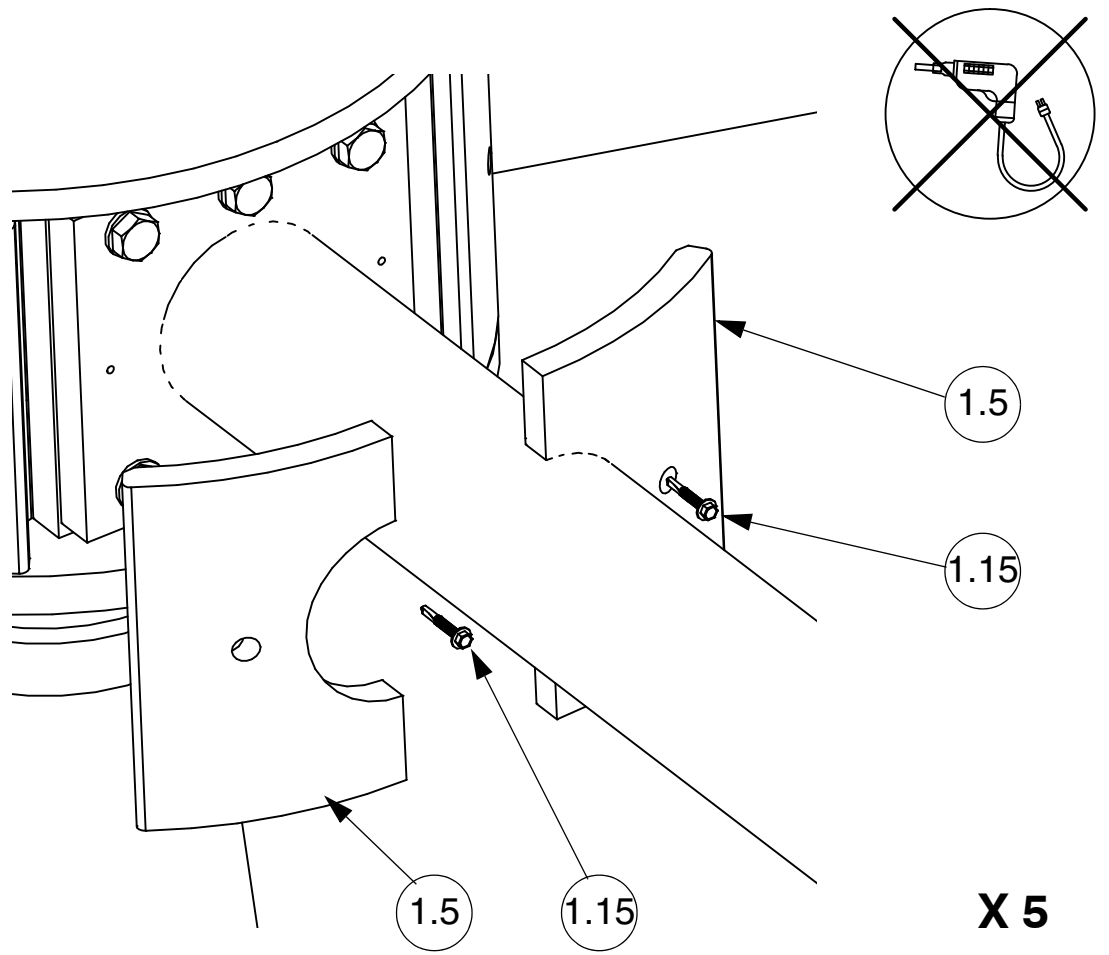

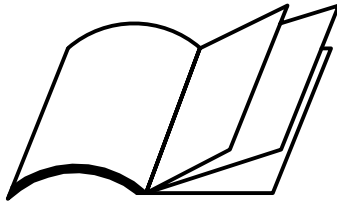

Section 2:

88020801

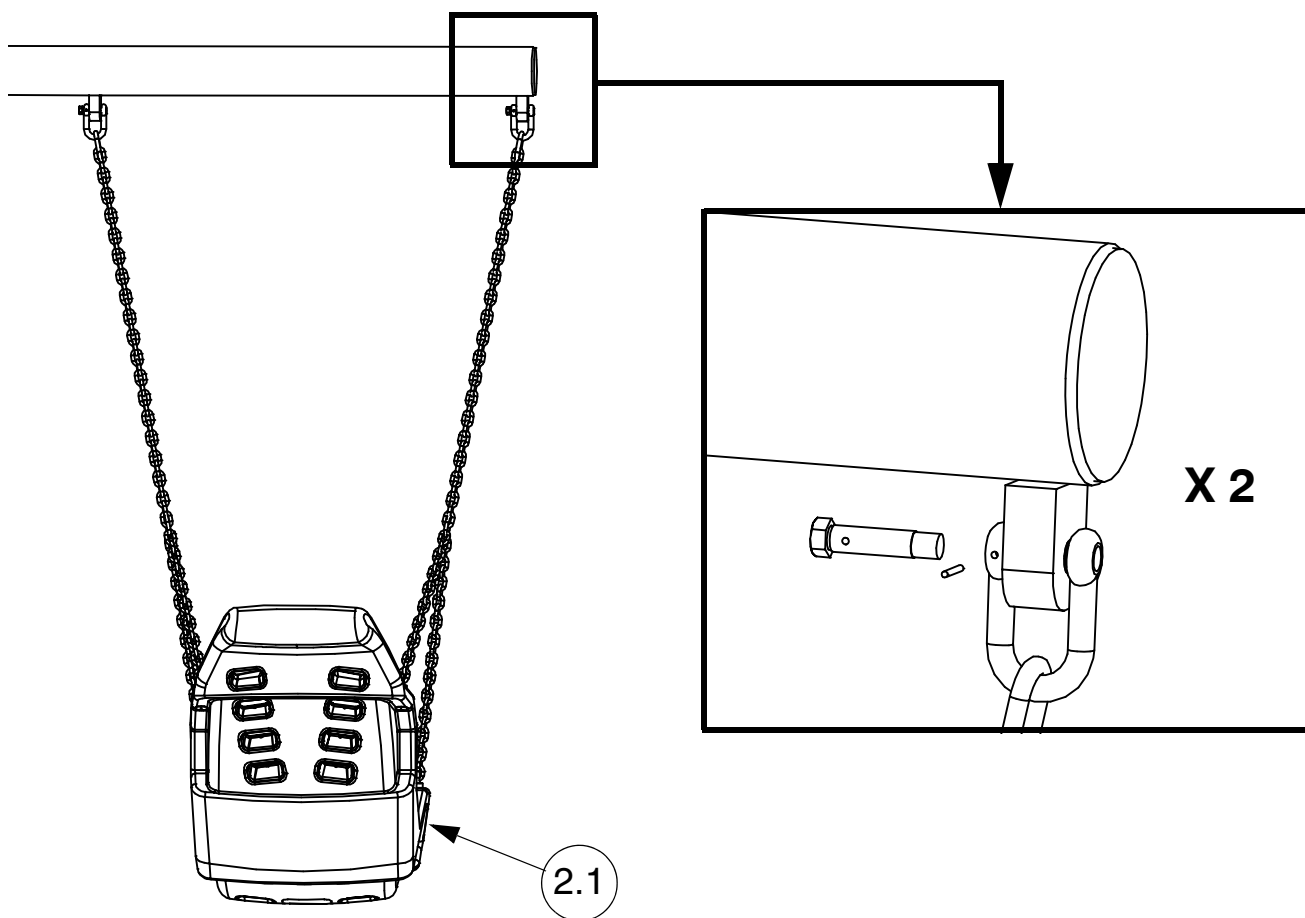

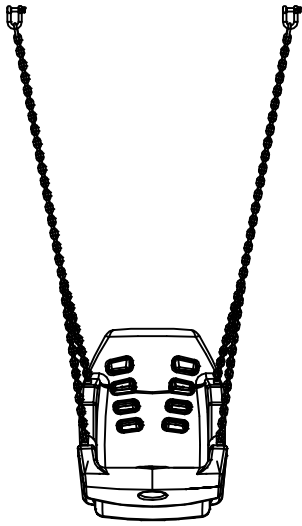
ITEM	REF		QTY	kg
2.1	88020801		1	13.50

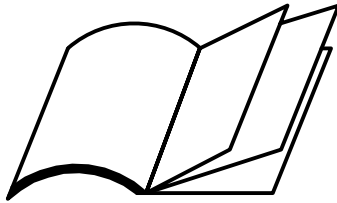

**Section 3:**

71240801

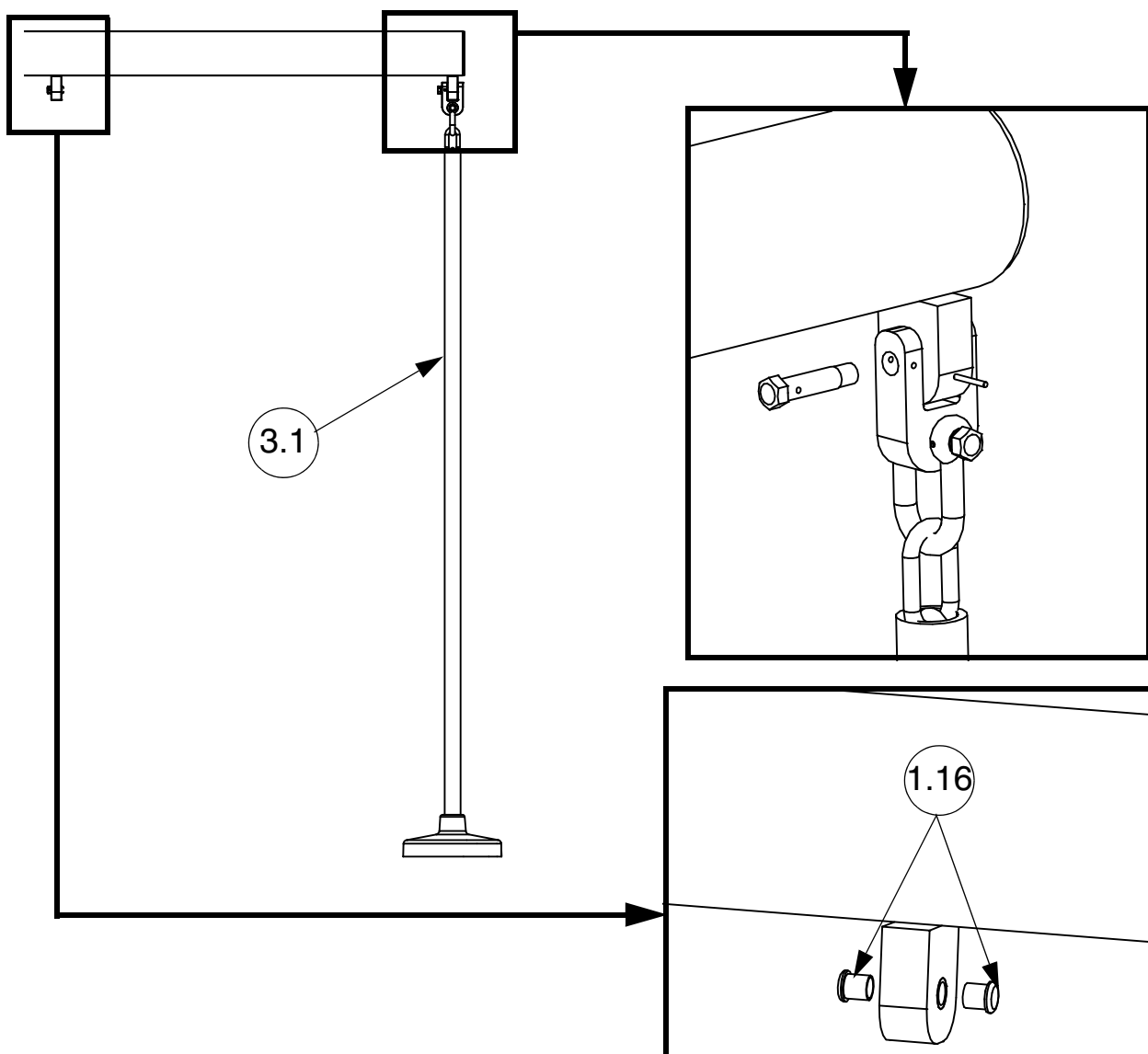

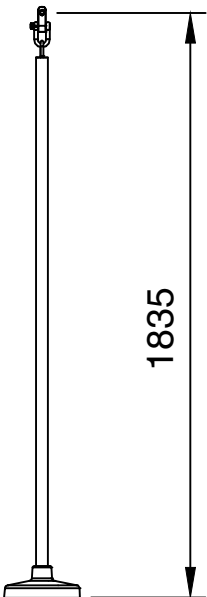
ITEM	REF		QTY	kg
3.1	71240801		1	5.25

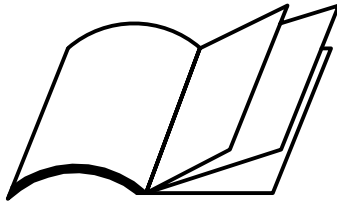

**Section 4:**

71240802

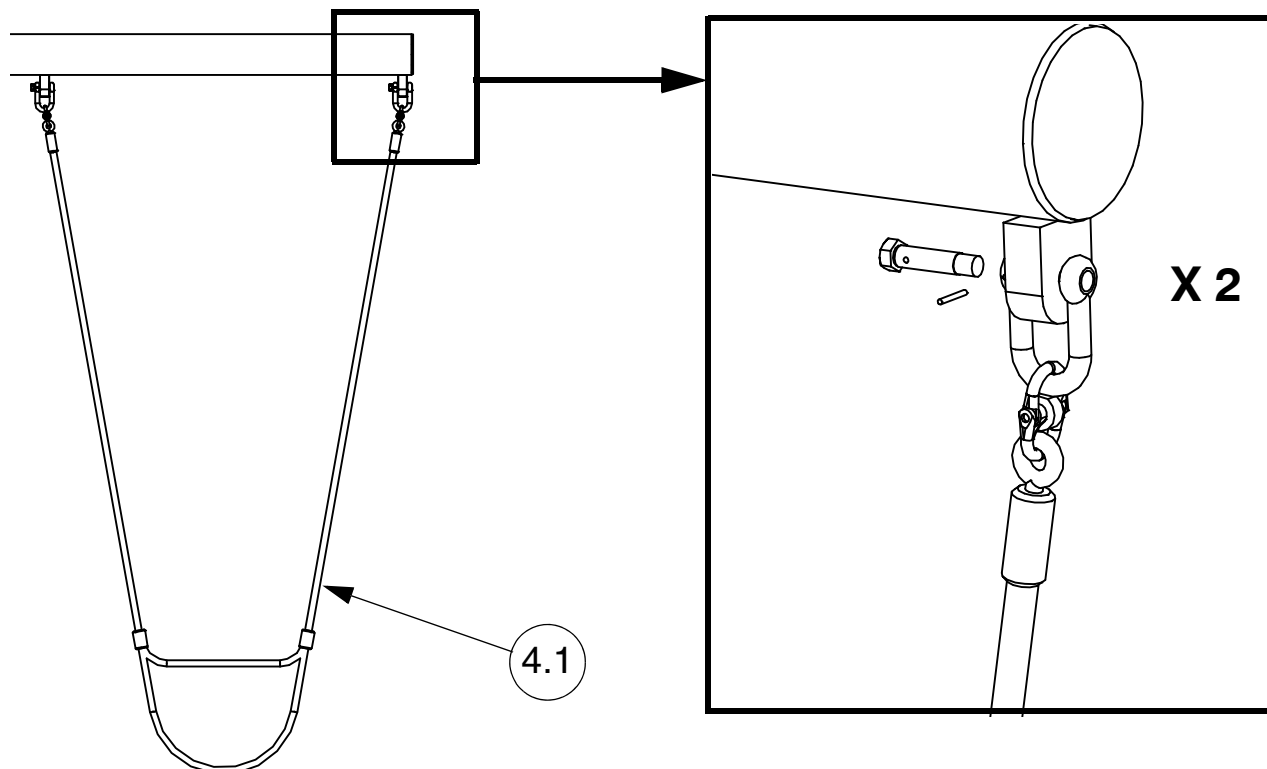

ITEM	REF		QTY	kg
4.1	71240802	<p>The drawing shows the same U-shaped lifting device as in the previous image. A vertical dimension line is drawn to the right of the device, spanning from the top of the two vertical arms to the bottom of the U-shaped frame. The number '1910' is written vertically along this dimension line.</p>	1	3.30

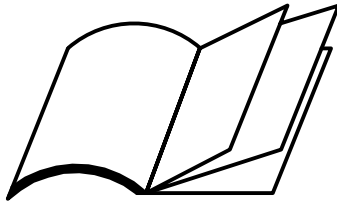

Section 5:

71240803

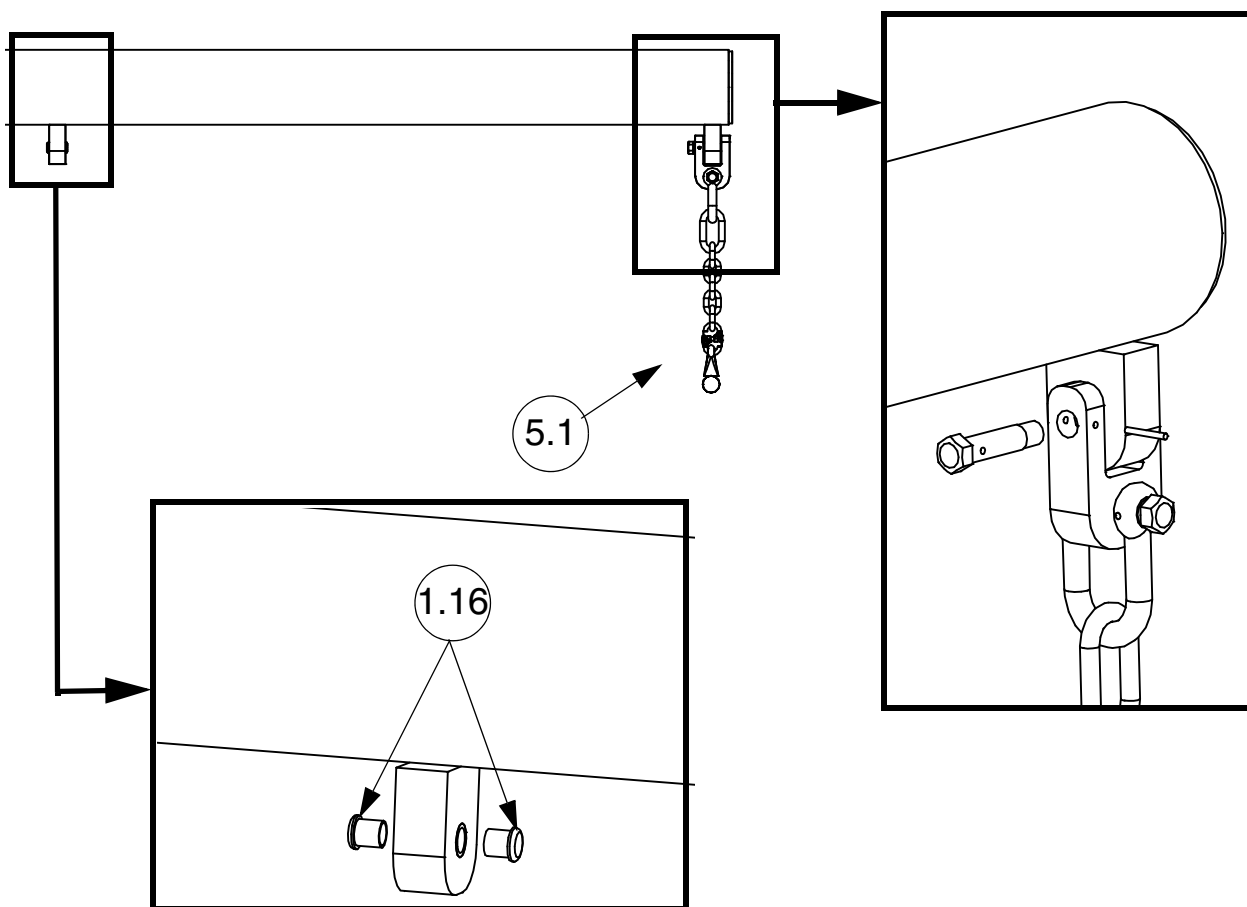

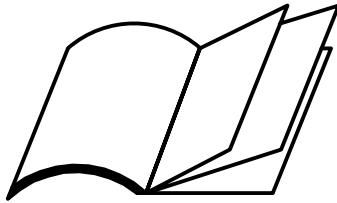

ITEM	REF		QTY	kg
5.1	71240803		1	1.25

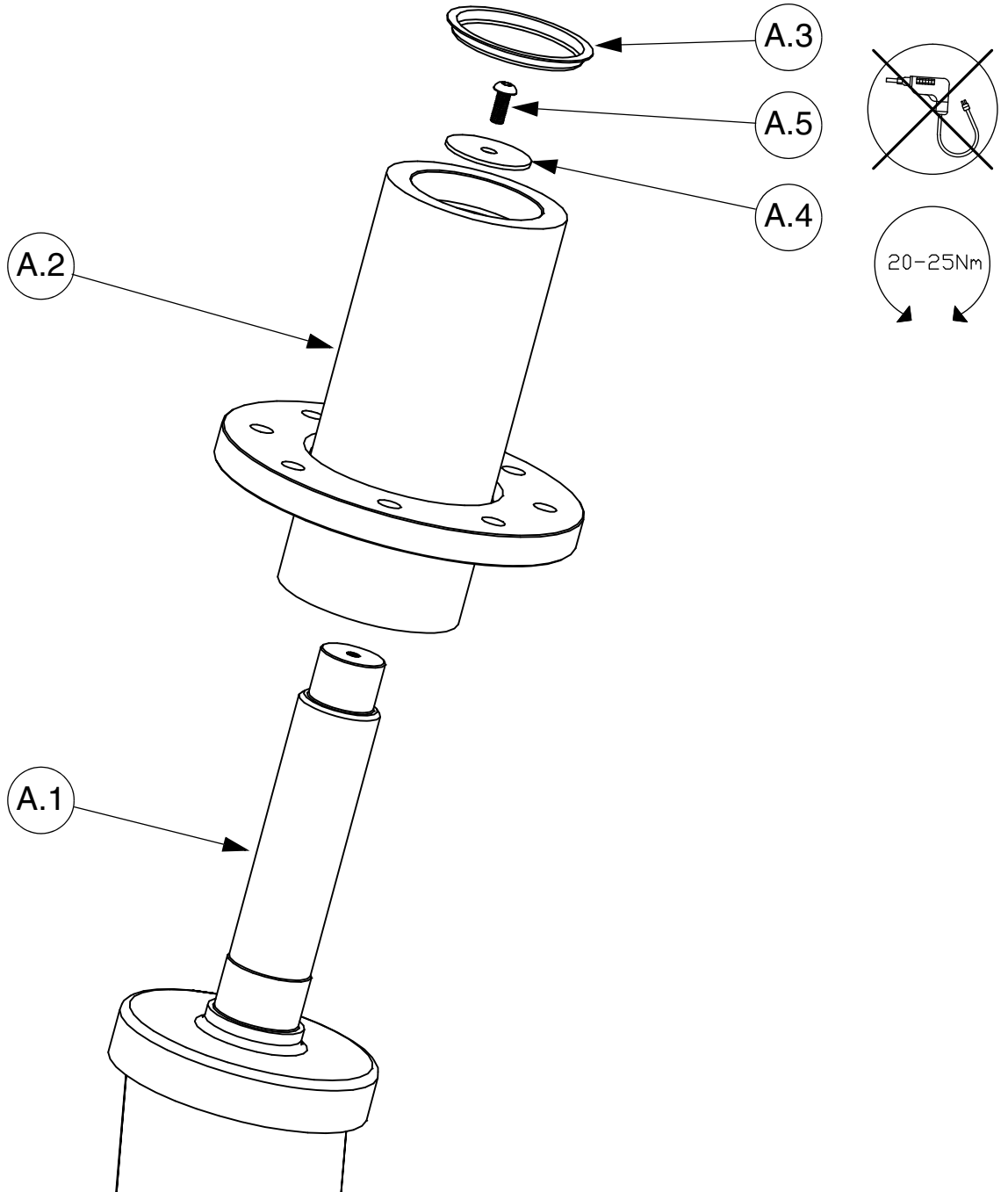

Appendix A:

71200100

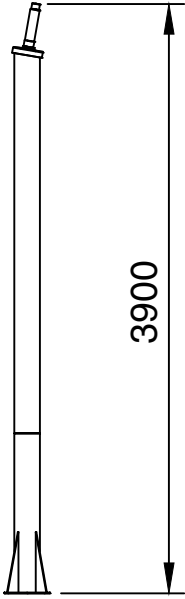
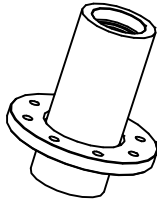

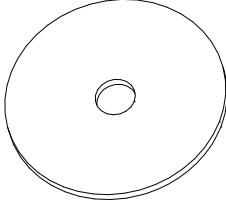
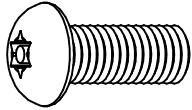
ITEM	REF	71200100	QTY	kg
A.1	71200300		1	116.00
A2	71200105		1	23.00
A.3	19055080		1	0.013
A4	71000109		1	0.08
A5	10121025	 M10 X 25	1	0.011

## Appendix B:

71200105

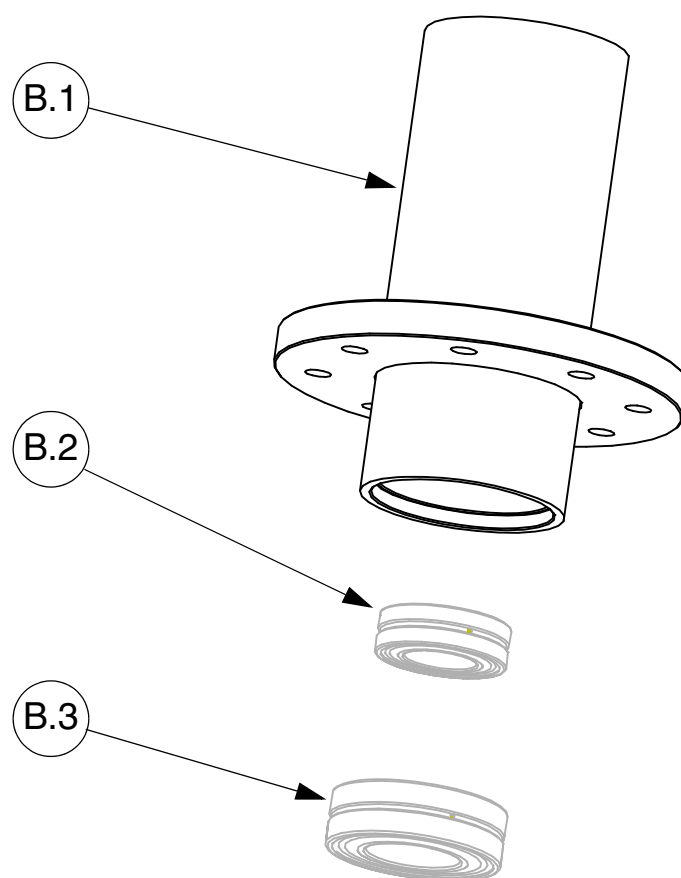

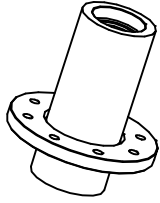
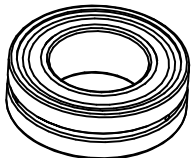
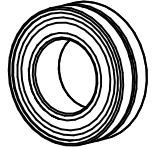
ITEM	REF	71200105	QTY	kg
B.1	71200310		1	21.00
B.2	71022210		1	0.70
B.3	71022213		1	1.60

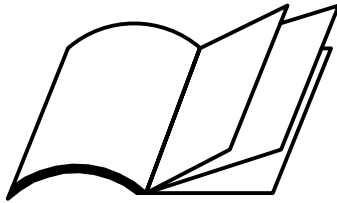

Appendix C:

71200110

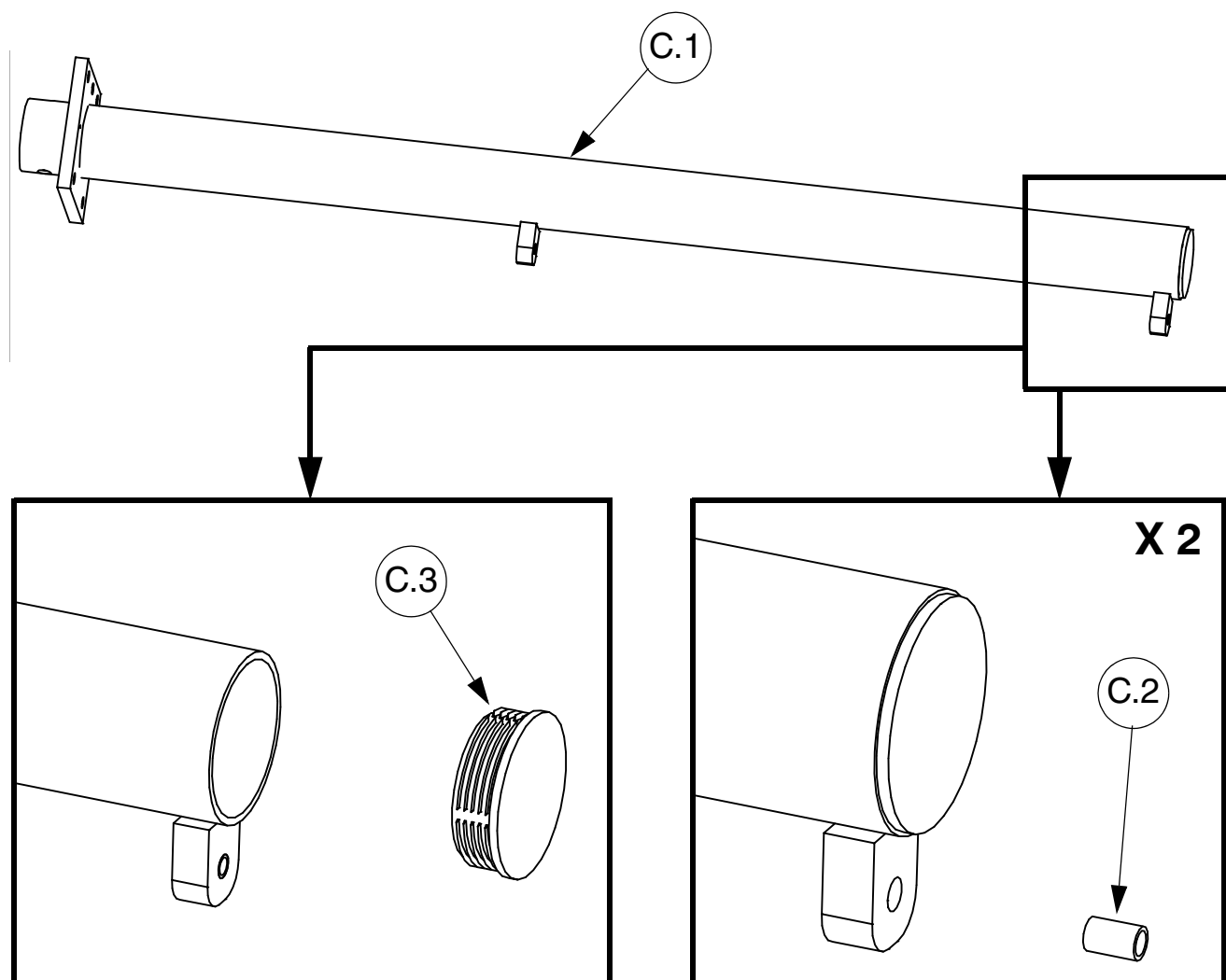



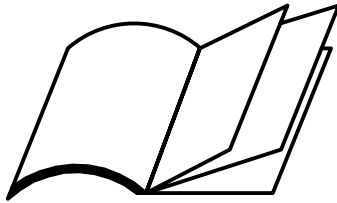

ITEM	REF	71200110	QTY	kg
C.1	71200325		1	30.00
C.2	15011612		3	0.002
C.3	19055100		1	0.052

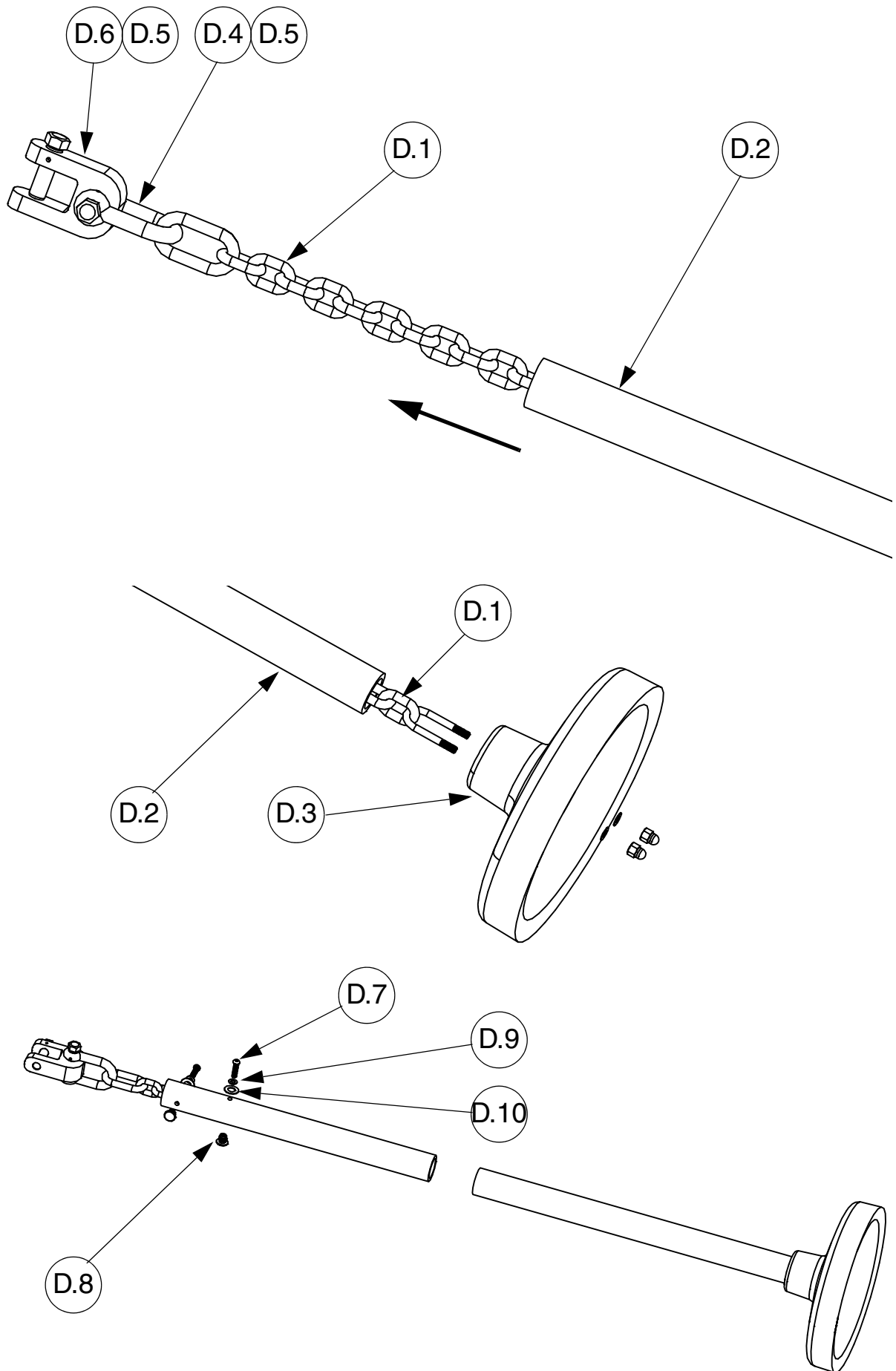

Appendix D:

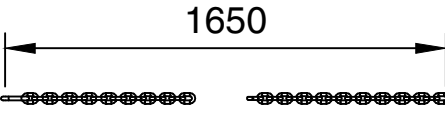
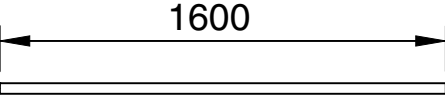
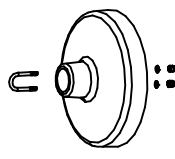
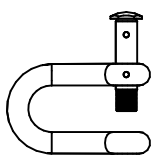
71240801

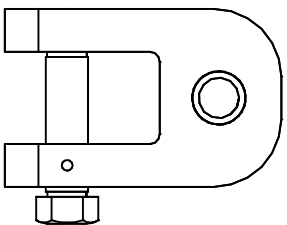
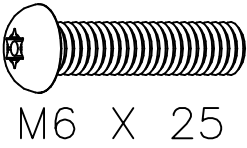

ITEM	REF	71240801	QTY	kg
D.1	71200510		1	3.75
D.2	71200515		1	1.00
D.3	109906		1	0.25
D.4	88096003		1	0.25
D.5	10310325		2	0.002
D6	71200115		1	0.50
D7	10120625		2	0.011
D8	10930600		2	0.006
D9	10290600		2	0.001

---

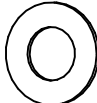

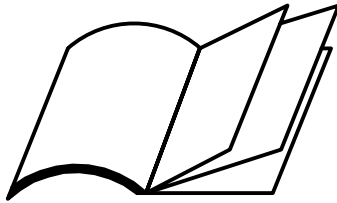
ITEM	REF	71240801	QTY	kg
D10	10291000	 M10 11X21X1	2	0.002

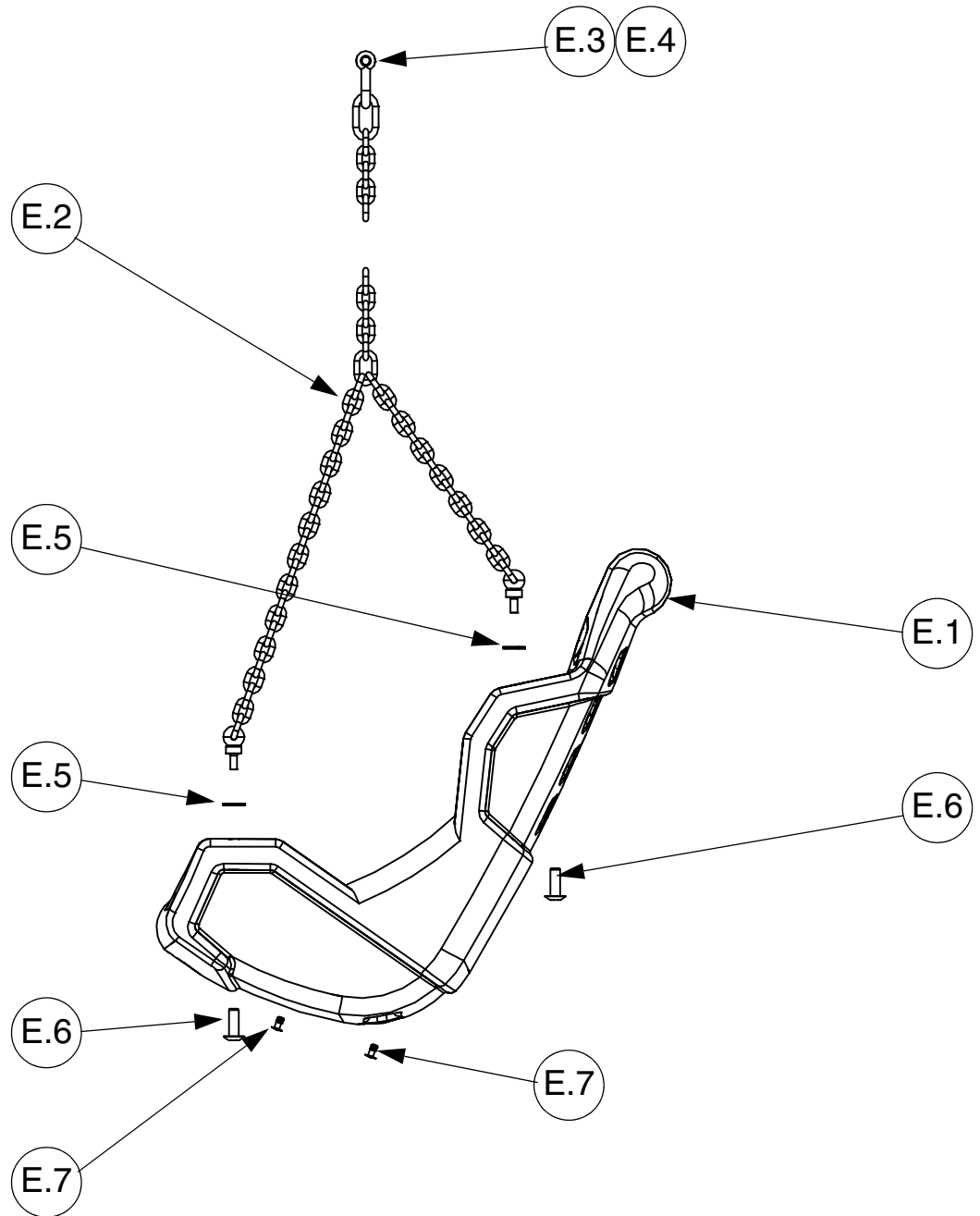

Appendix E:

88020801

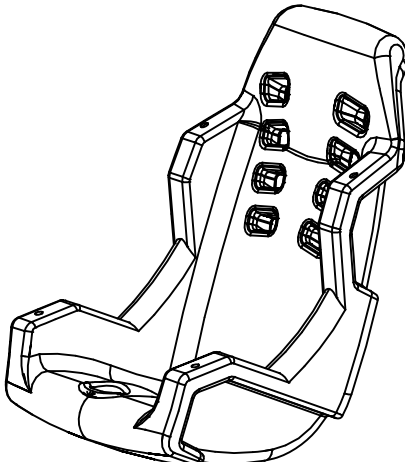
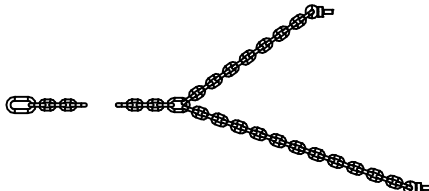
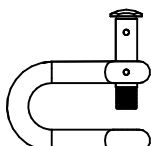

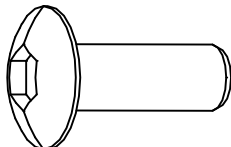
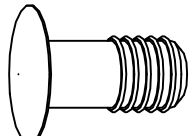
ITEM	REF	88020801	QTY	kg
E.1	88020801		1	6.70
E.2	88020802		1 PAIR	6.00
E.3	88096003		2	0.25
E.4	10310325		2	0.002
E.5	10303212	 T5 13X32X2.6	4	0.011
E.6	88020902		4	0.054
E.7	19024501		4	0.001

## Appendix F:

71240802

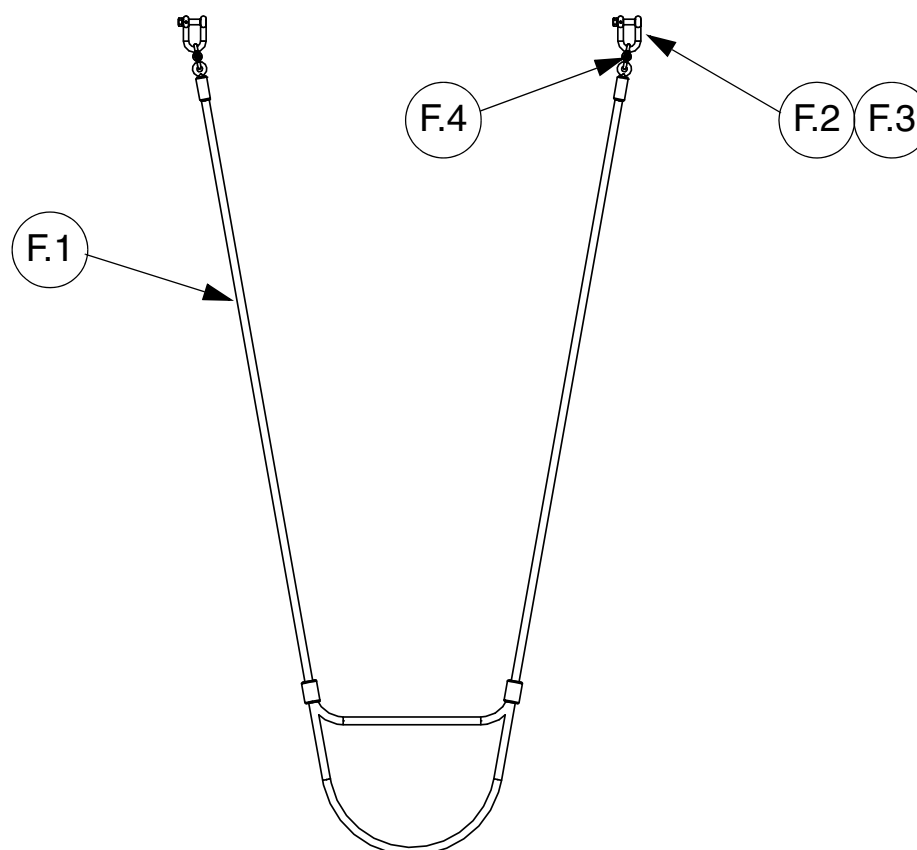



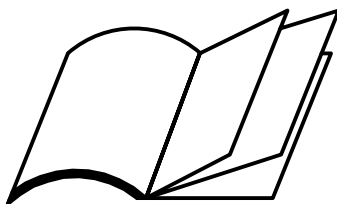

ITEM	REF	71240802	QTY	kg
F.1	71200540		1	2.50
F.2	88096003		2	0.25
F.3	10310325		2	0.002
F.4	15716000		2	0.100

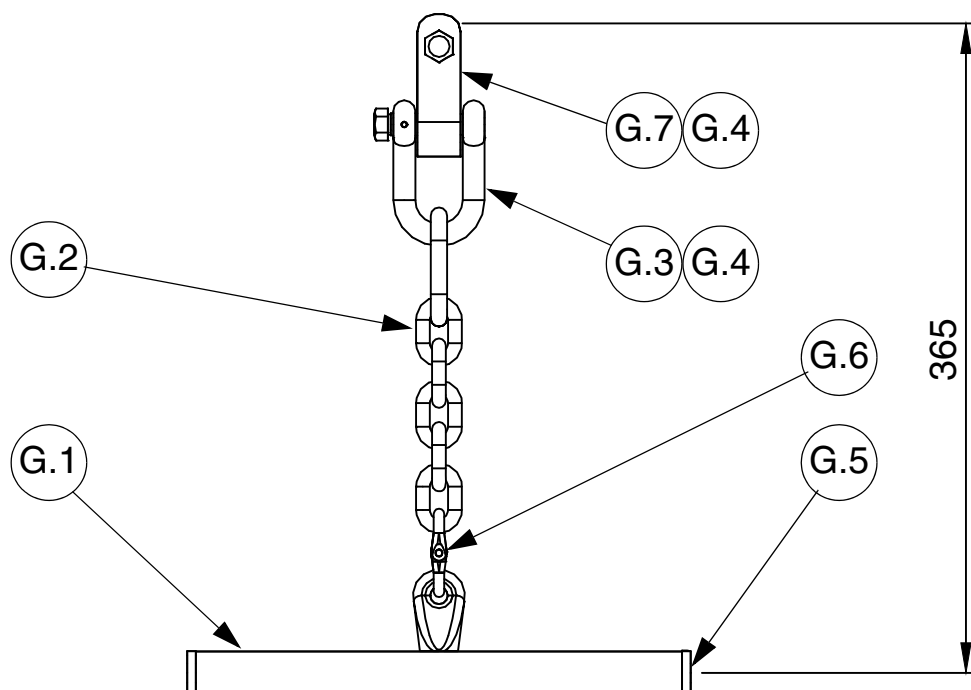

## Appendix G:

71240803

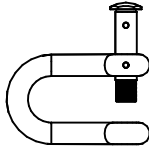

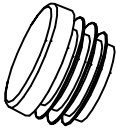
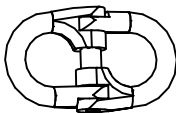
ITEM	REF	71240803	QTY	kg
G.1	71200330		1	0.40
G.2	71200520		1	0.60
G.3	88096003		1	0.25
G.4	10310325		2	0.002
G.5	409118		2	0.004
G.6	15715000		1	0.100

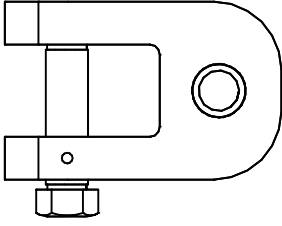
ITEM	REF	71240803	QTY	kg
G.7	71200115		1	0.50

Appendix H:

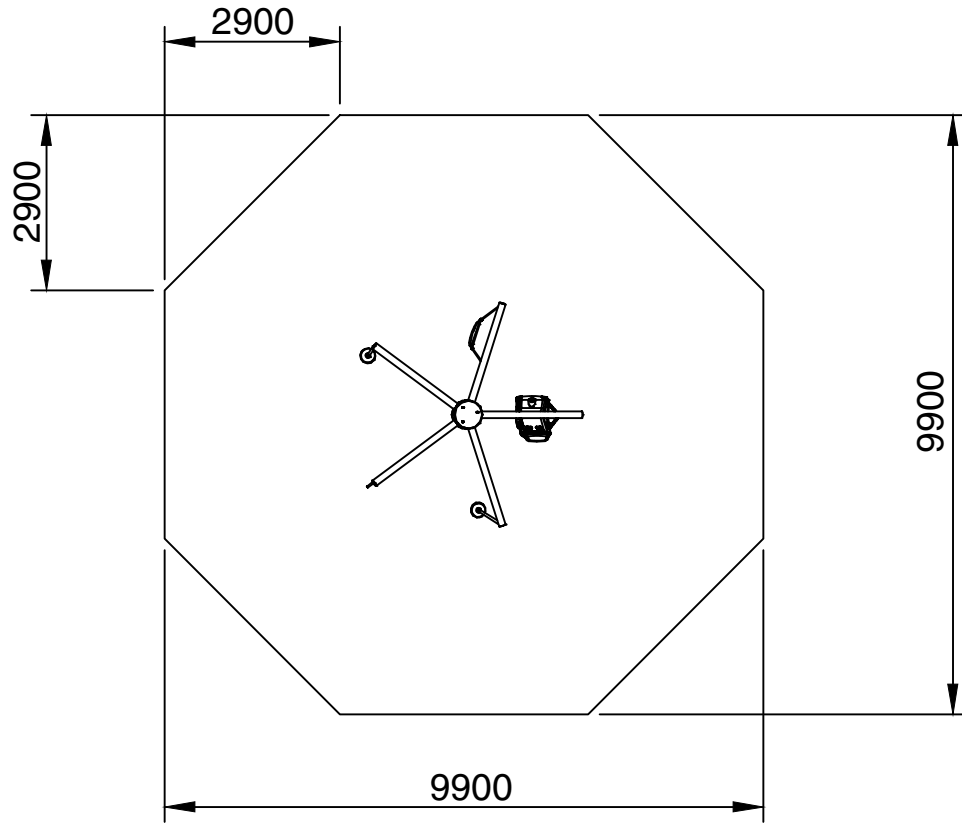

TYPE 3 SYNTHETIC

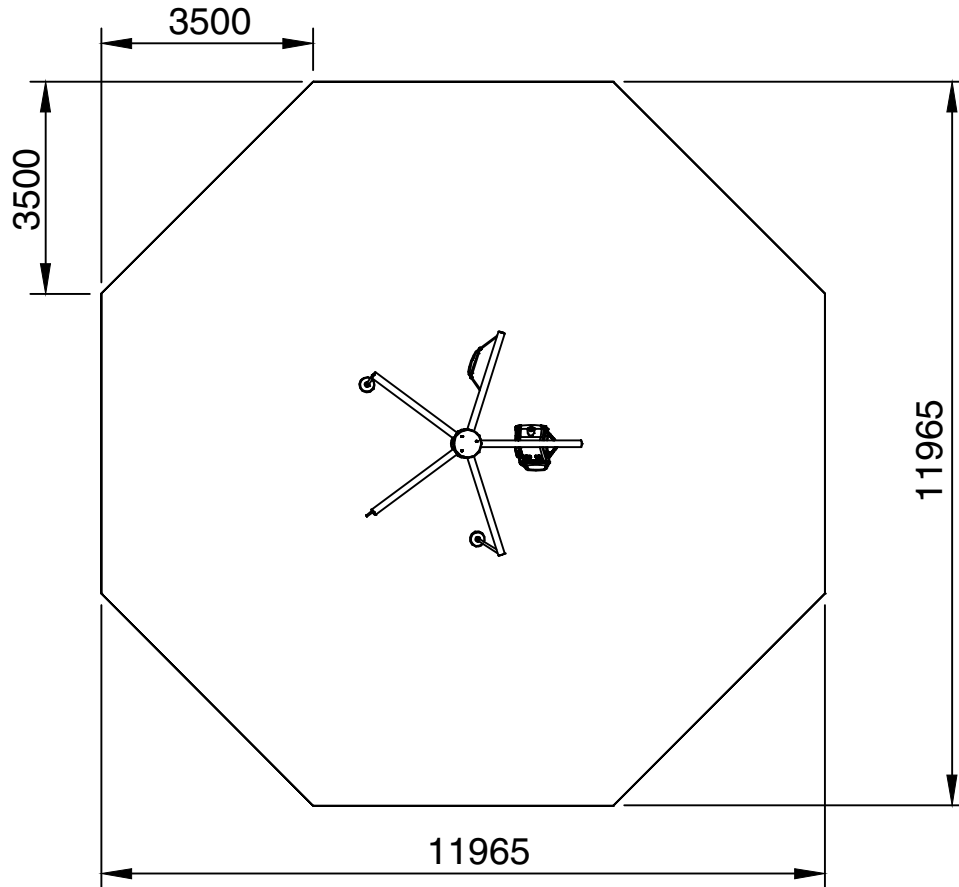



TYPE 1/2 LOOSEFILL

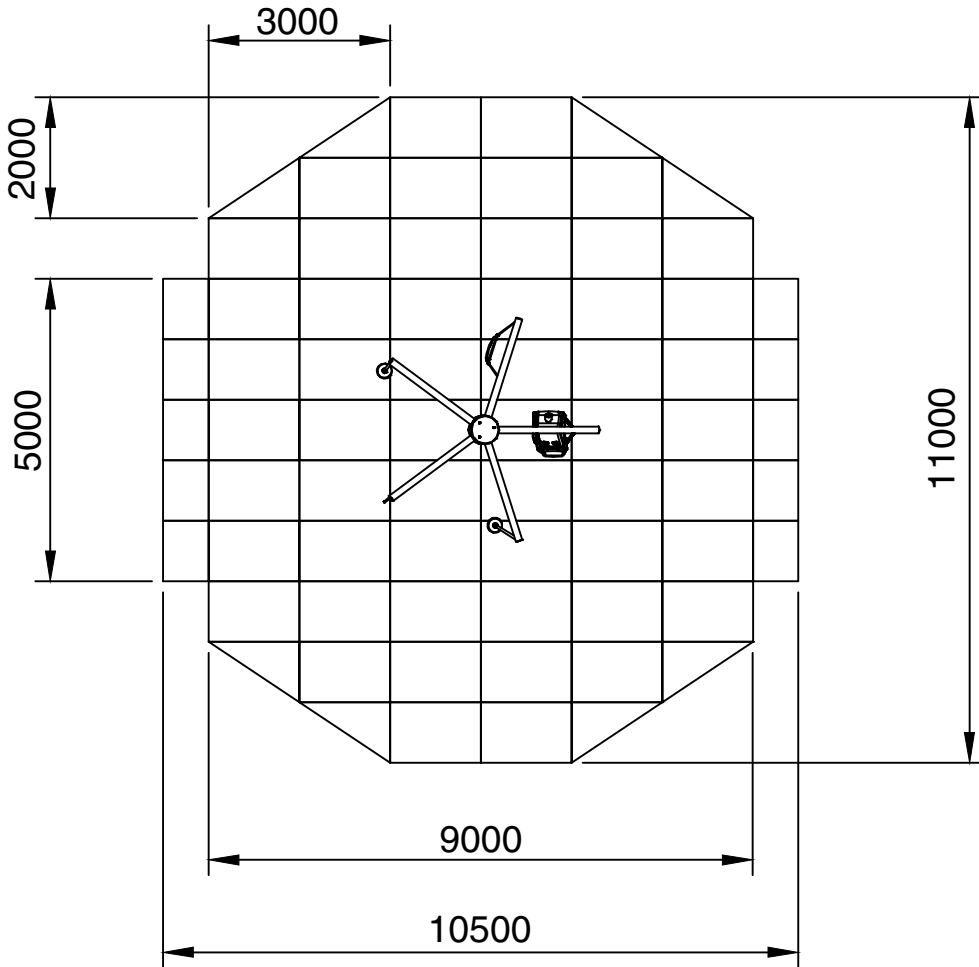

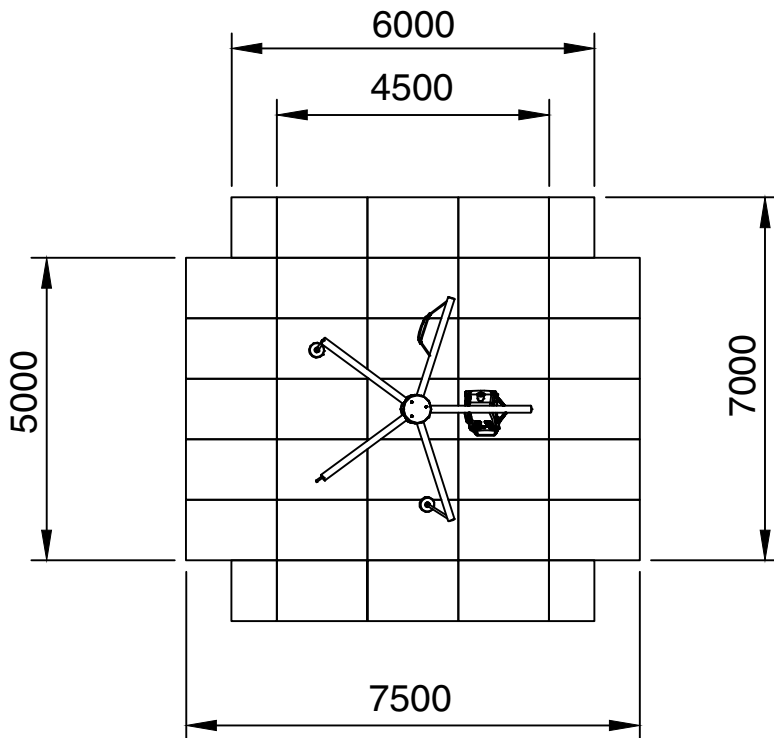

TYPE 5 GRASSMATT FR  144



TYPE 5 GRASSMATT FR - WEAR AREA  144

---

## 1 SAFE WORKING PRACTISE

A full risk assessment should be carried out prior to commencing the installation, which will be specific to the site selected. The major risks associated with purely the assembly of this product are highlighted below, which can form part of this overall assessment.

### 1.1 RISKS:

- i) Large parts which could be difficult to lift or handle.
- ii) Structure unstable until concrete footings have fully cured.
- iii) Parts at height that may require working overhead.
- iv) Heavy parts at height that require support during assembly

### 1.2 CONTROL MEASURES:

- i) Warn the public of the risk of injury, by placing signs and fencing the surrounding area, before commencing installation.
- ii) All staff working on installation to wear suitable PPE including Toe Protective Shoes, Hard hat and Gloves.
- iii) Any staff or other persons on site, not working directly on the installation, to be kept away from the installation.
- iv) Ensure adequate personal and equipment are on site to handle and support the structure whilst it is being assembled.
- v) Suitable working platform to provide secure access and provide support for parts required.

## 2 SPECIFICATIONS

SMP Playgrounds Ltd recommends an effective *Impact Absorbing Surface tested to EN1177 & BS7188* beneath this play equipment. Refer to manufacturers instructions for details of installation. The surface should have a Critical Fall Height greater than the Maximum Free Fall Height of the equipment.

Constructional Space is the approximate working area required to lay out and assemble the equipment.

For the safe operation of this equipment it must be installed on horizontal ground with the required minimum space.

The concrete foundations indicated are for average ground. Care should be taken concerning abnormal conditions.

If a loose fill surface is selected for this item it will require a very high level of maintenance to ensure a sufficient thickness is in place at all times to provide 'critical fall height' protection.

Care should be taken when siting this equipment in order to discourage users in the surrounding area from unintentionally coming into contact with the equipment. This can be achieved, for example by placing the equipment at the perimeter of the play area.

**NOTE:** In addition to the free space and the falling space, there shall be an additional area extending at least 1m free from obstacles.

## 3 PREPARATION

All equipment assembly and fixing must conform to EN1176.

**Tools / ancillary equipment:** It is recommended that suitable lifting equipment be used at all times when installing this piece of equipment.

Mobile Platform, 10m tape measure, Spirit level, M10 Torx tool (Supplied with unit), Torque wrench with metric sockets, 10mm A/F Allen Key, M16 Cranked Ring Spanner. Loose fill: Masking tape, Paint brush, Black paint.

### 3.1 ESTABLISH ORIENTATION

- i) See Specifications for equipments 'Minimum space'.
- ii) Measure out the site to ensure the space required fits into the allotted area, it is horizontal and free from trip points or other obstructions.
- iii) Ensure the equipment is to be provided with an effective Impact Absorbing Surface which has a tested critical fall height rating greater than the maximum Free Fall Height of the equipment.

### 3.2 MARK OUT HOLES

Consult SMP layout drawing for structure position on site.

See **page 4** for concrete foundation size.

**NOTE:** This is a minimum guide only.

### 3.3 ESTABLISH DATUM LEVEL

- i) If a rubber tiled Impact Absorbing surface is to be laid, see separate instructions (base may incorporate up to 2% falls etc).
- ii) If equipment is to sit in loose fill or wet pour rubber surfaces allowances will need to be made for its recommended thickness. Generally it is recommended that loose fill surfaces are installed to a depth of 400mm, however, with certain loose fill materials an alternative depth may be required. This will need to be determined by allowing 100mm for the dispersal in addition to the thickness required for the particular Free Fall Height. The foundation illustrated will allow for a thickness up to 400mm.

### PRE-INSTALLATION INSPECTION

Inspect all parts for damage (that may have occurred during transportation & storage). Finish Coatings, if found to be damaged these should be made good before erection (Refer to maintenance instructions). Any damaged or missing parts must be replaced.

## 4 INSTALLATION & ASSY PROCEDURES

- i) Refer to site layout for position and orientation of product, then, mark the outline of the position of the footings with e.g. spray or chalk etc. Excavate the holes. **See page 4.**
- ii) Attach Ground Mounting Frame (item 1.6) to Ground Mounting Assembly (item 1.1) using 4 off M10 x 25 Resistorx bolts (item 1.11) and M10 Washers (item 1.13). Fully tighten to 20-25Nm. **(STEP 1).**
- iii) Secure Top Hub (item 1.2) on to the Ground Mounting Assembly (item 1.1) and secure using 8 off M16 x 50 Button Head Screws (item 1.9) and M16 Washers (item 1.12). Fully tighten to 120-130Nm. **(STEP 2)**
- iv) Use suitable lifting equipment to position assembly into excavation. Pack up to correct height ensuring assembly is level and plumb. **(STEP 3A & B)**
- v) Brace assembly into position. **(STEP 3A & B)**
- vi) Fill the hole with concrete to the required level, taking into account any Impact Absorbing Surfacing requirements. Ensure that the full volume of concrete is used. The top of the concrete should gradually (1:100) slope down & outwards locally from the equipment upstand to the required level to form a watershed.

Concrete mix is recommended at:

1 part cement;  
2 parts sand;  
4 parts aggregate;  
by volume with 20mm aggregate  
(20 N/mm<sup>2</sup> min compressive strength)

- vii) Keep installation off limits to the public until the concrete has completely cured. (Recommended initial curing time is 48 hours).
- viii) If installation is with a loose fill type surface, the support column should be marked with 'Basic level mark' to indicate the recommended finished surface level.

- ix) Insert the end of the Arm Assembly (item 1.3) into the Top Hub (item 1.2) and insert M20 x 130 Hex. Bolt (item 1.7) through hole in end of tube. **(STEP 4)**
- x) Secure the Arm Assembly (item 1.3) using 5 off M16 x 75 Hex. Bolts (item 1.8), 10 off M16 Washers (item 1.12) and 5 off M16 Nylock Nuts (item 1.14). Fully tighten to 180-220Nm. **(STEP 4)**
- xi) Repeat ix) and x) for the remaining 4 arms. **(STEP 4)**
- xii) Place Top Cover (item 1.4) onto the Top Hub (item 1.2) and secure using 3 off M10 x 35 Resistorx Bolts (item 1.10) and 3 off M10 Washers (item 1.13). **(STEP 5)**
- xiii) Place a Plastic Cover (item 1.5) either side of the mounting plate on the Arm assembly (item 1.3) and secure using 2 off TECH 5 x 40 fixings (item 1.15). **(STEP 6)**
- xiv) Repeat xiii) for the remaining 4 arms. **(STEP 6)**
- xv) See Sections 2, 3, 4 & 5 for methods of fixing the hanging units from the rotating arms to complete the equipments assembly.
- xvi) After fixing all hanging units ensure all unused bearing blocks are fitted with Plastic plugs (item 1.17) from both sides.

## 5 POST INSTALLATION INSPECTION

<b>CHECK</b>	<b>CHECK</b>	✓
1 The unit is installed at the correct height.	<input type="checkbox"/>	<input type="checkbox"/>
2 All fixings are tightened to the correct torque and have no protruding sharp edges.	<input type="checkbox"/>	<input type="checkbox"/>
3 Paint work and polyethylene covers are not damaged (Any making good should be carried out using the procedure in the Inspection and Maintenance instructions).	<input type="checkbox"/>	<input type="checkbox"/>
4 The hanging frame rotates freely.	<input type="checkbox"/>	<input type="checkbox"/>
5 Sel-Lok-Pins are inserted.	<input type="checkbox"/>	<input type="checkbox"/>
6 Swing Shackles move freely.	<input type="checkbox"/>	<input type="checkbox"/>
7 Ensure all plastic plugs are correctly fitted.	<input type="checkbox"/>	<input type="checkbox"/>
8 Concrete foundations are secure.	<input type="checkbox"/>	<input type="checkbox"/>
9 Concrete has a water shed away from leg.	<input type="checkbox"/>	<input type="checkbox"/>
10 Adequate provision of Impact Absorbing Surfacing with no obstructions or other hazards within the equipments minimum space.	<input type="checkbox"/>	<input type="checkbox"/>
11 Site is clear of all tools and rubbish.	<input type="checkbox"/>	<input type="checkbox"/>
12 Remove any warning signs.	<input type="checkbox"/>	<input type="checkbox"/>

