



Bringing together leading brands in the play industry



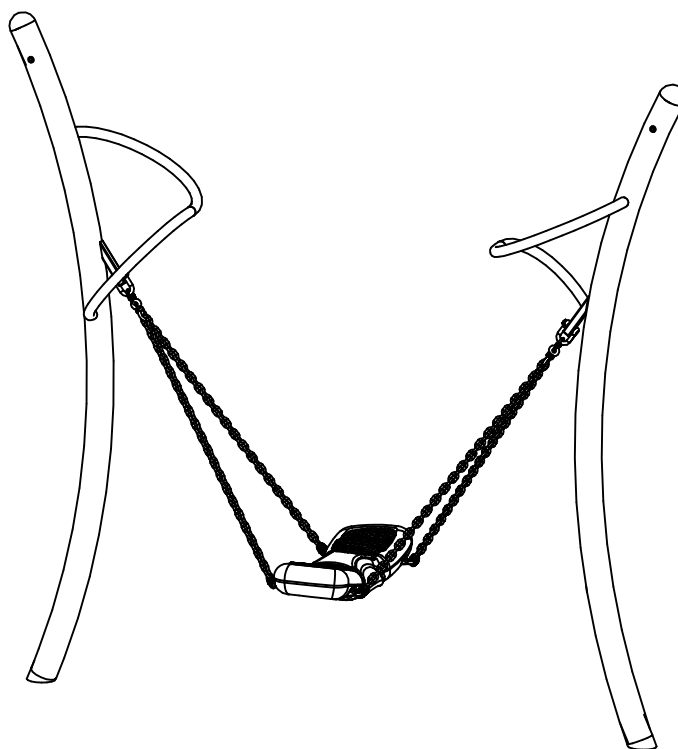

## INSTALLATION INSTRUCTIONS

# NEXUS FREERIDE

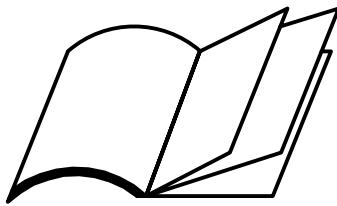
## NXFRR

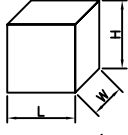
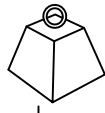

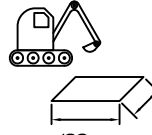
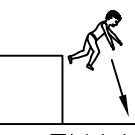

						 x 2=T
	LxWxH (m)	kg	m <sup>3</sup>	m	≥EN1176	
NXFRR	2.40 x 0.69 x 2.25	96.5	1.59	6.00 x 5.00	1.30m	T=3h

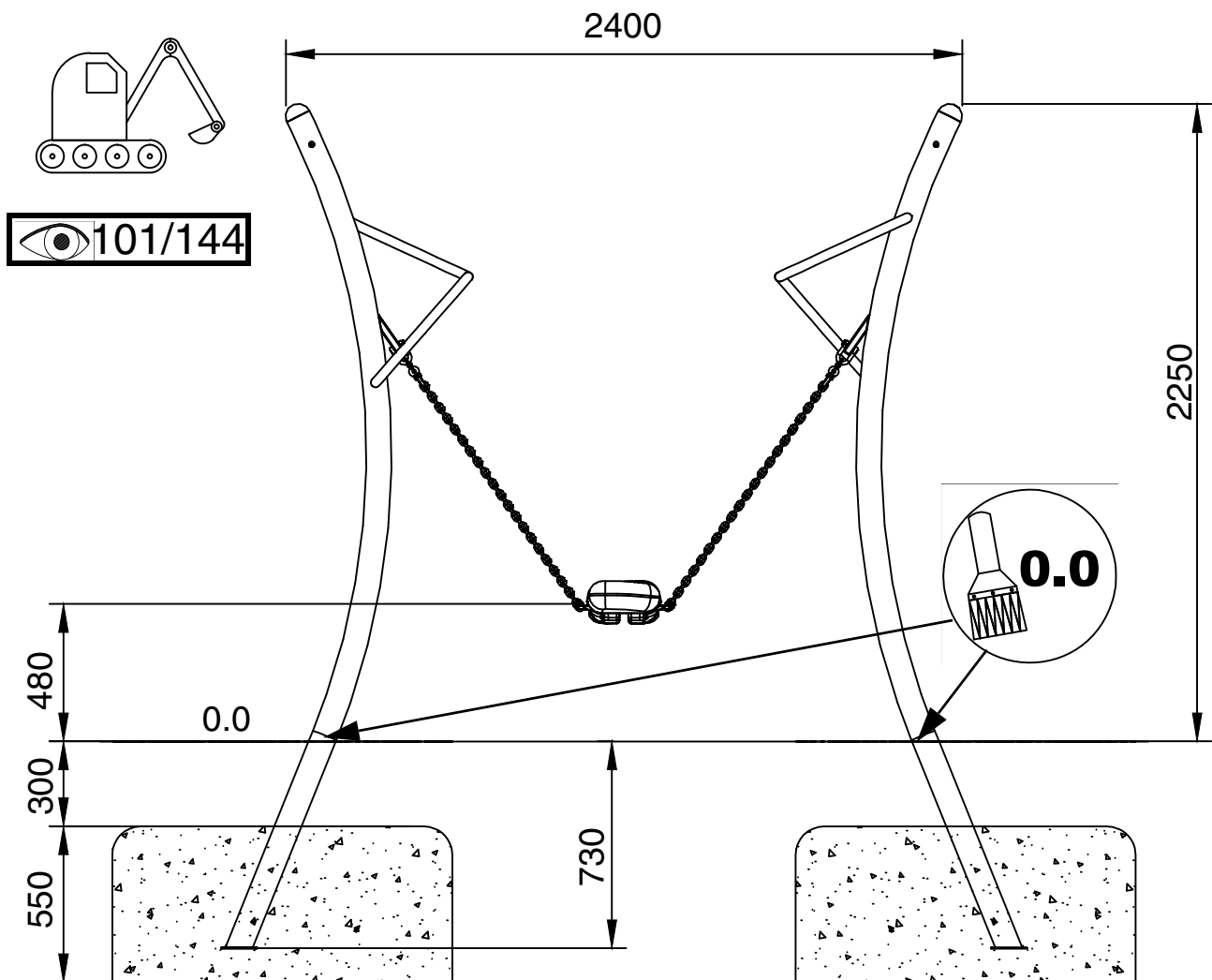
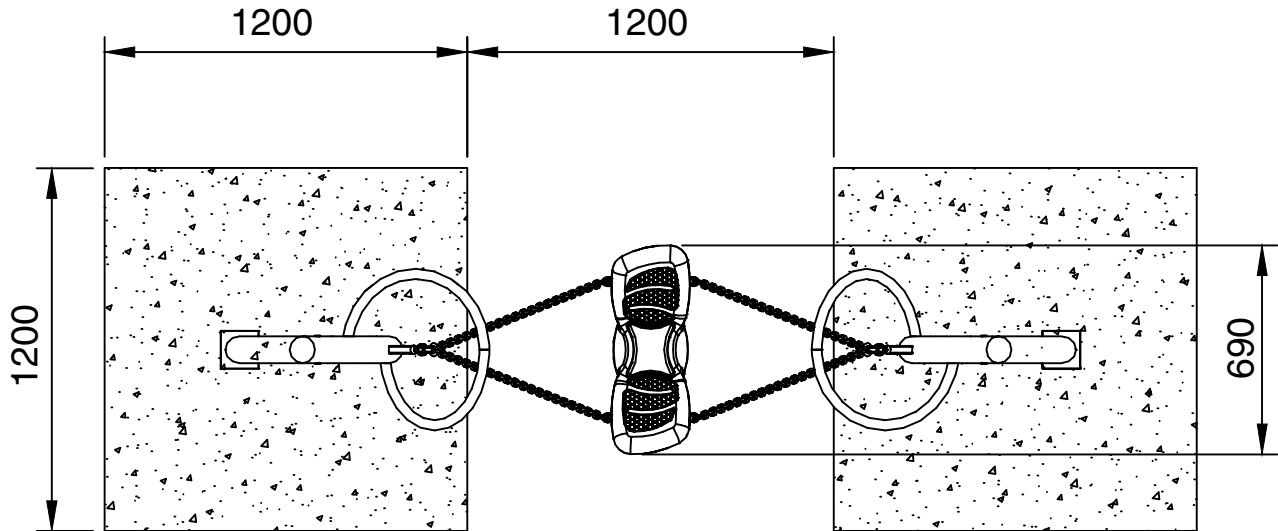

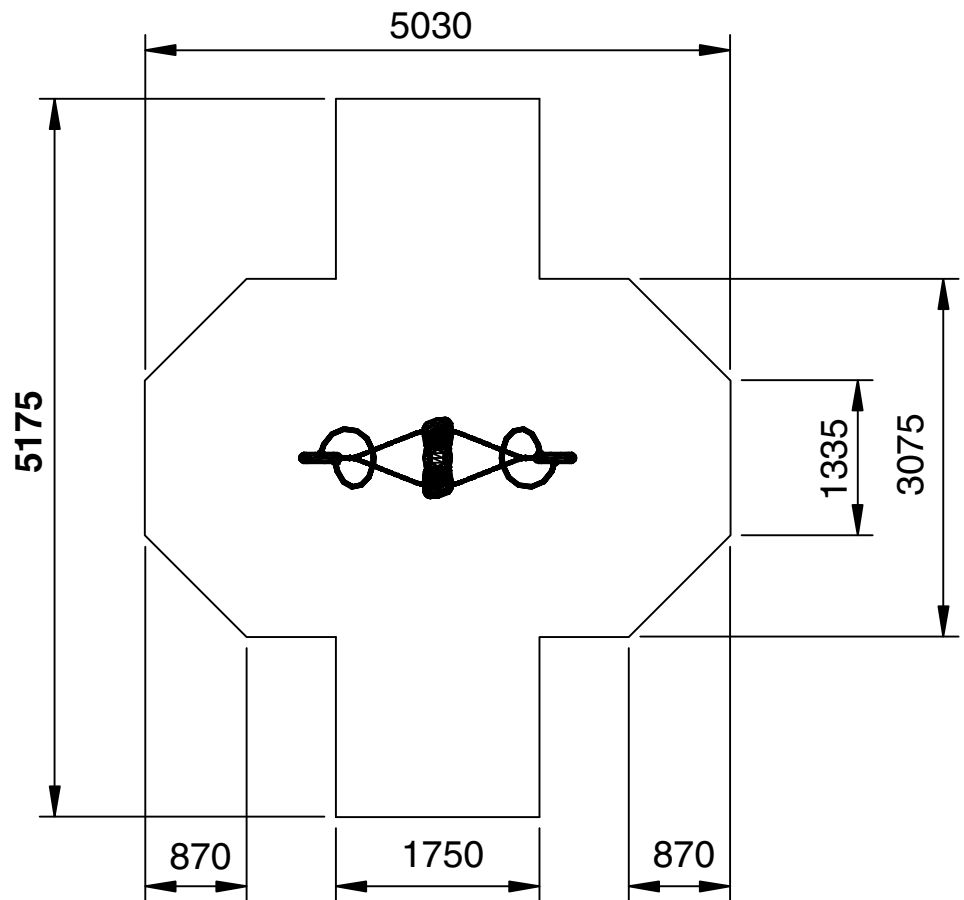
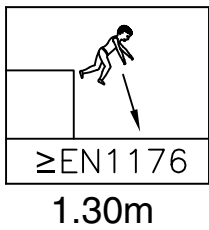
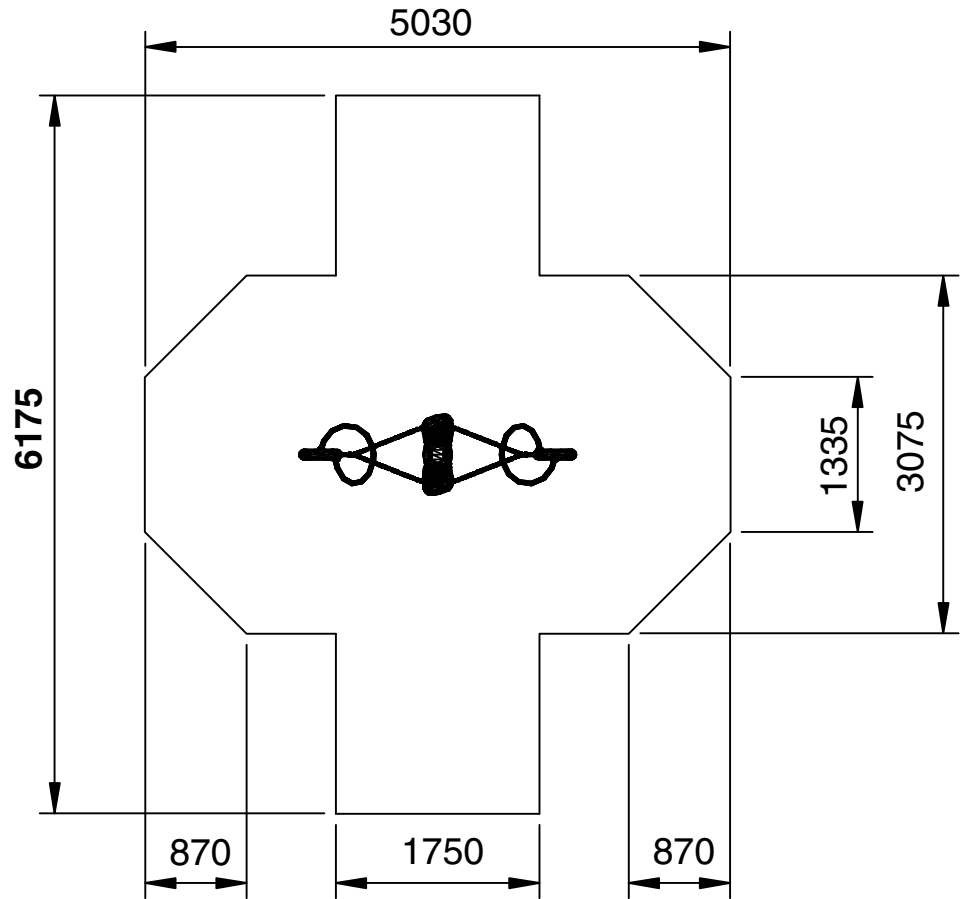
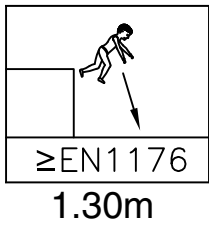

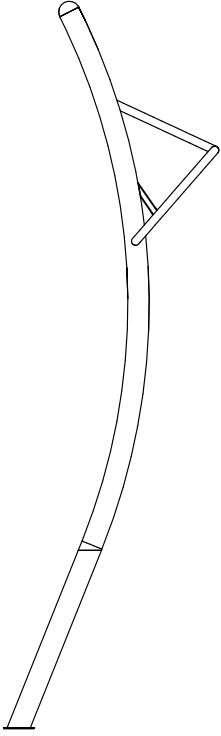
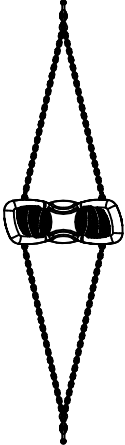
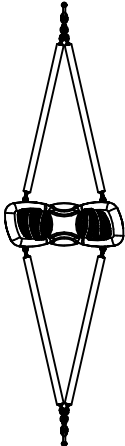
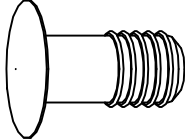

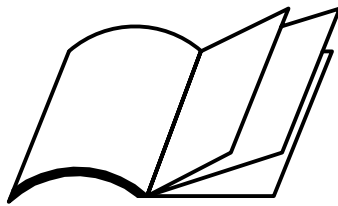
ITEM	REF.	NXFRR	NXFRR(HS)		kg
1	37000101A			2	35.00
2	37001001			1	13.00
	37001005			1	15.40
3	19024501			4	0.001

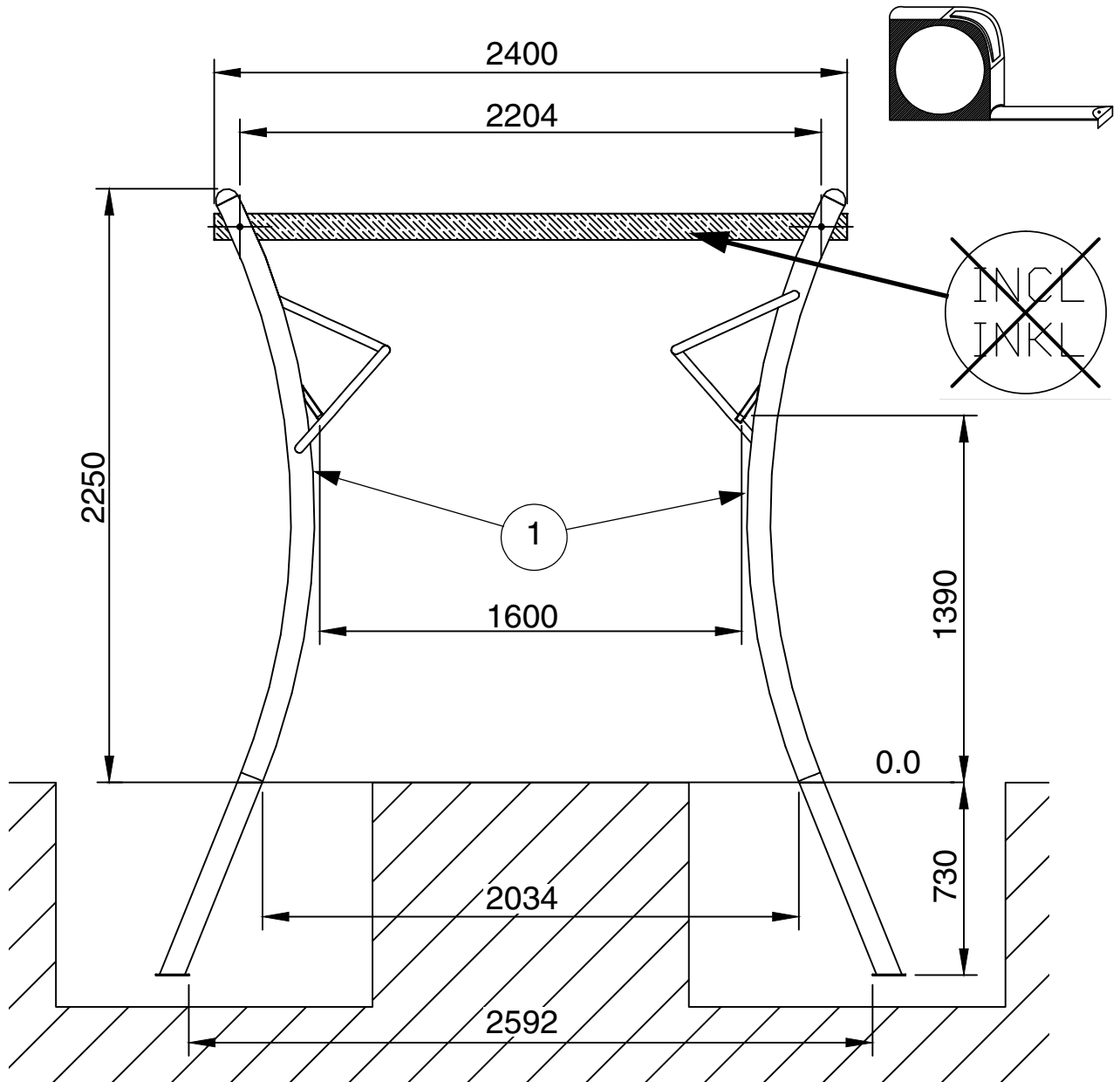

# STEP 1

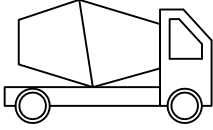

	
S2 (50mm)	
≥C20-25	
	7 x 24h
	101



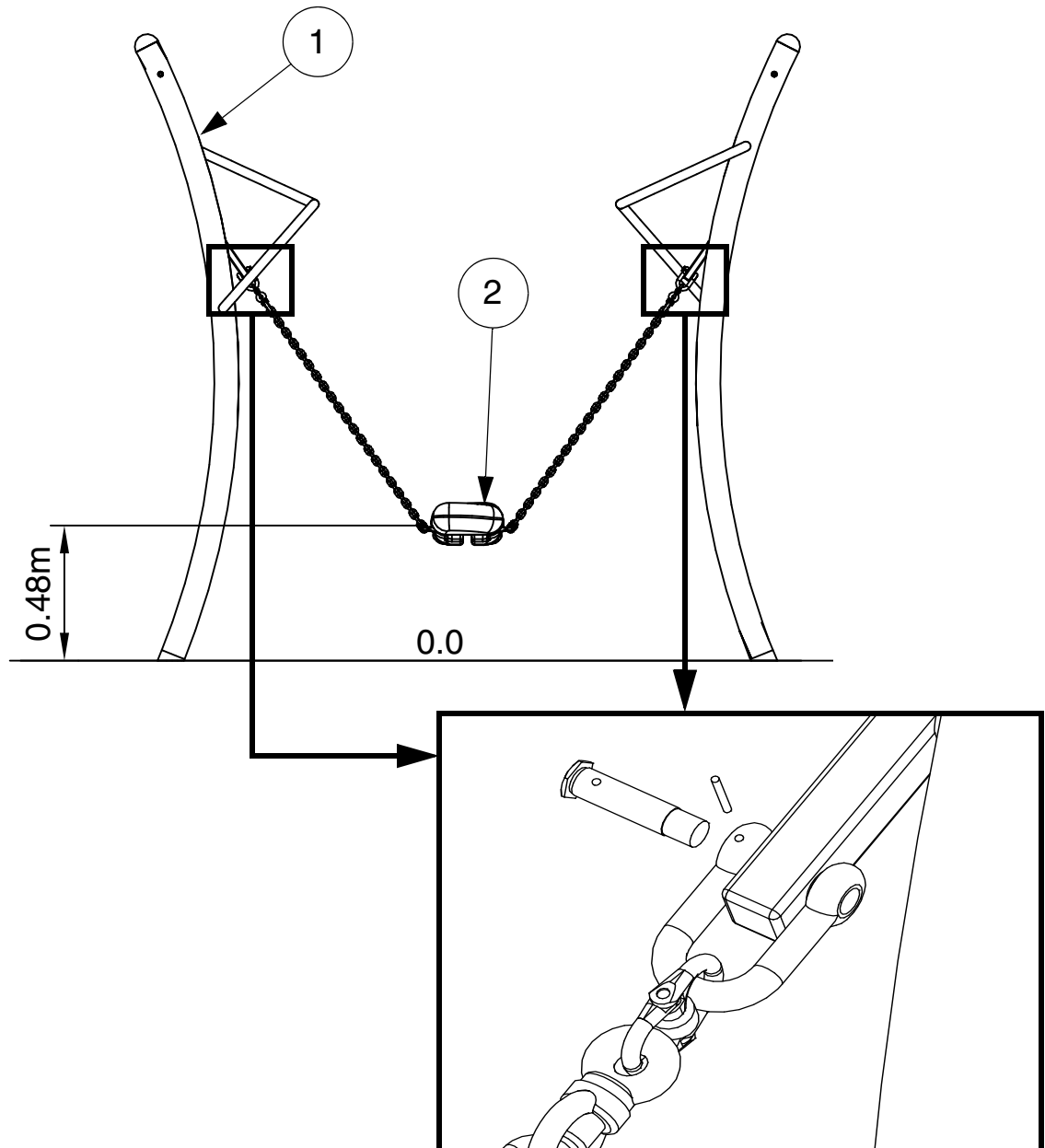

## STEP 2

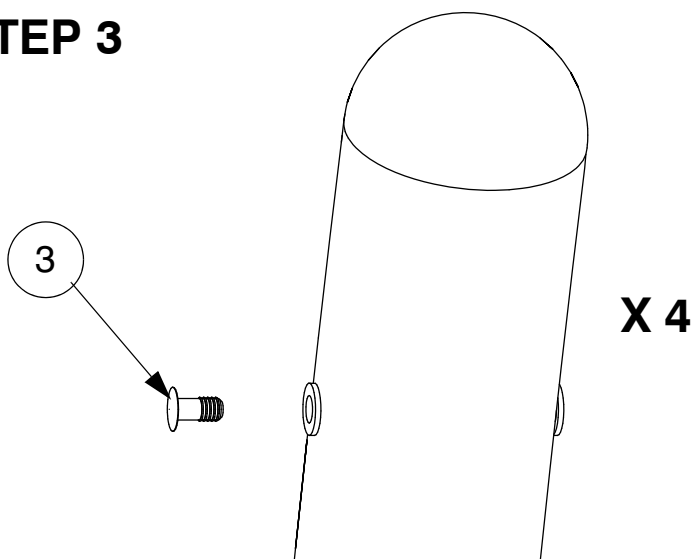

## STEP 3

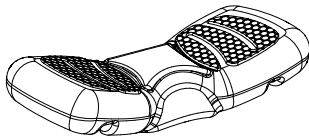
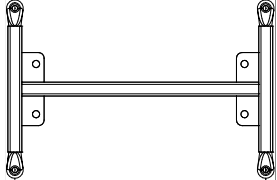
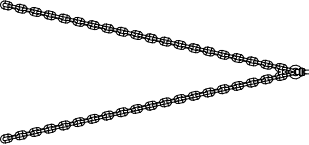
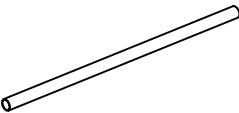
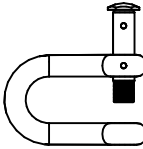

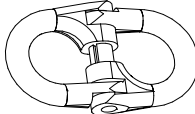
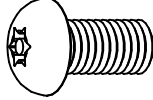
**Appendix A:**  
**REF 37001001 / 37001005**

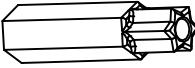
ITEM	REF	37001001	37001005	QTY.	WEIGHT (kg)
A1	37001003			1	3.000
A2	37001004			1	3.000
A3	37001002			2	3.000
A4	37001006			4	0.600
A5	88096003			2	0.250
A6	10310325			2	0.002
A7	15716000			2	0.100
A8	15715000			4	0.100
A9	10121020	 M10 X 20		4	0.020
A10	10291000	 M10 11X21X1		4	0.002
A11	10121000	 T45 M10		1	

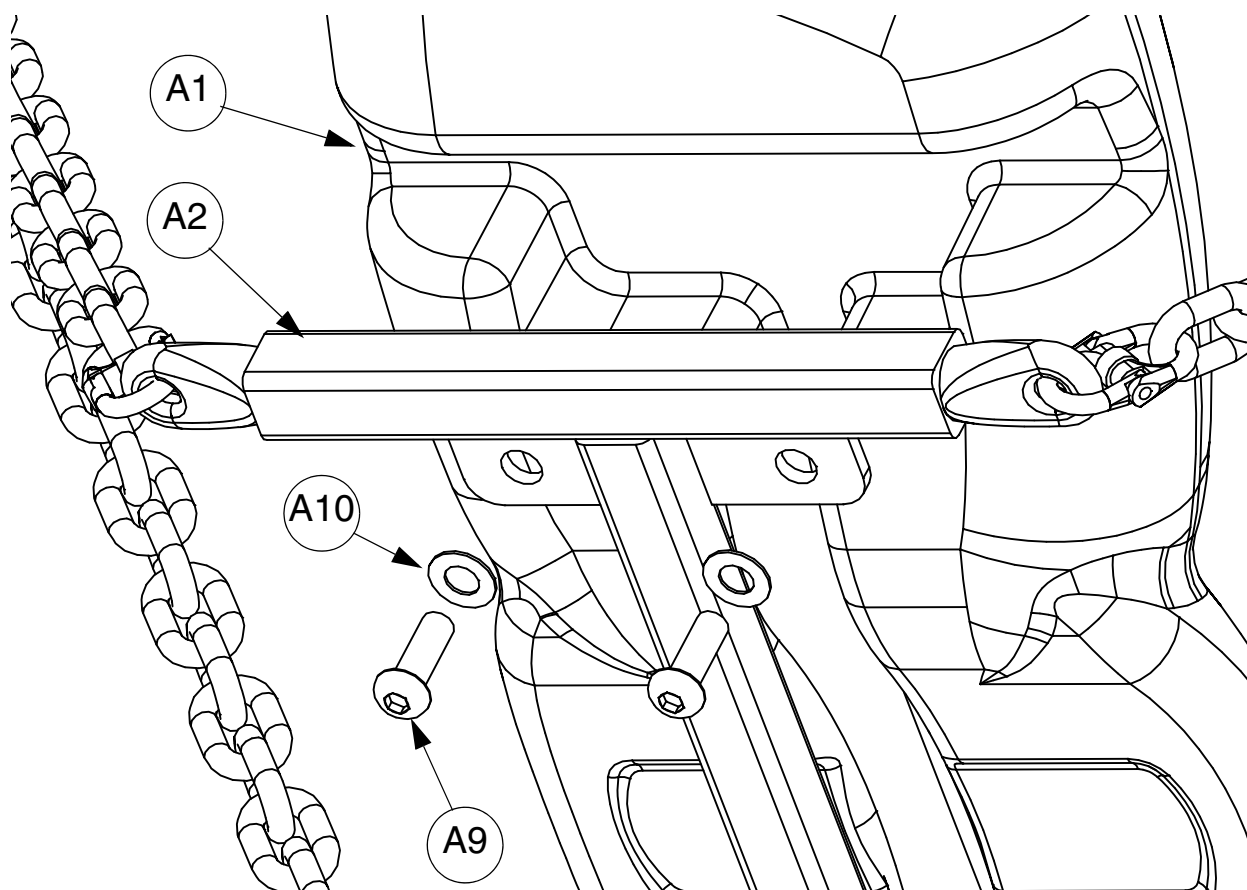

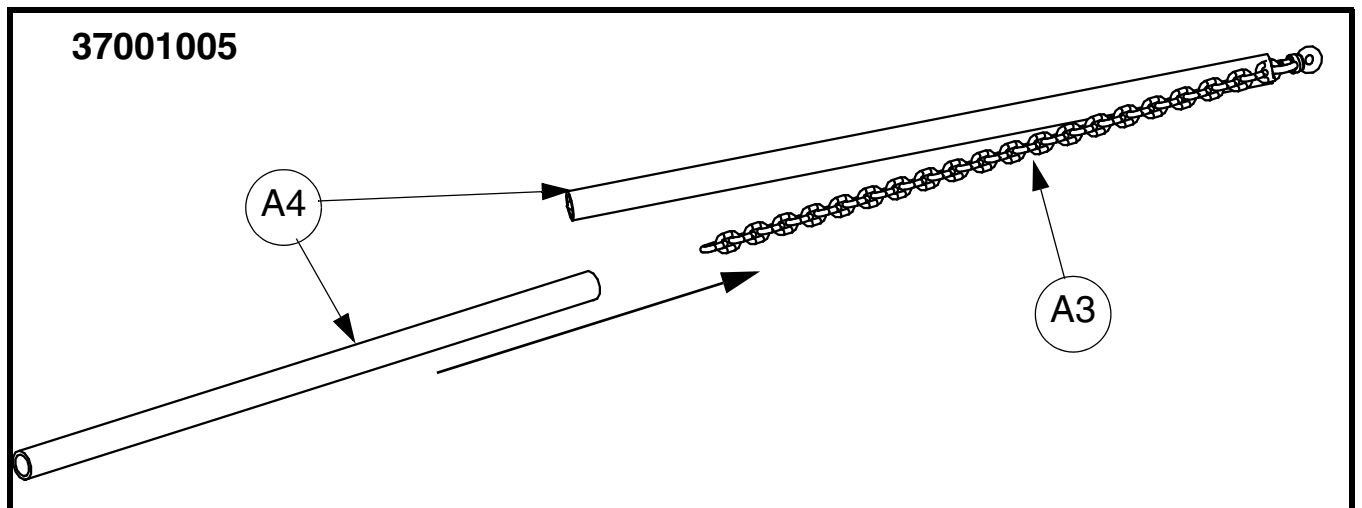
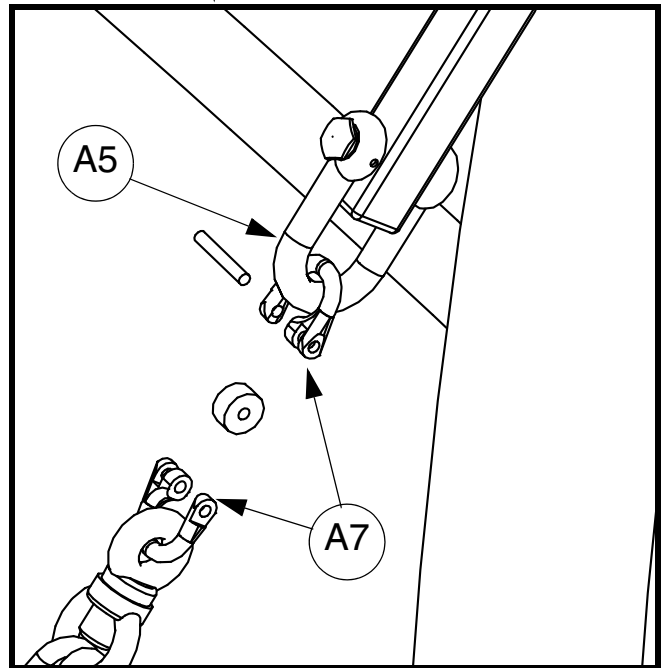
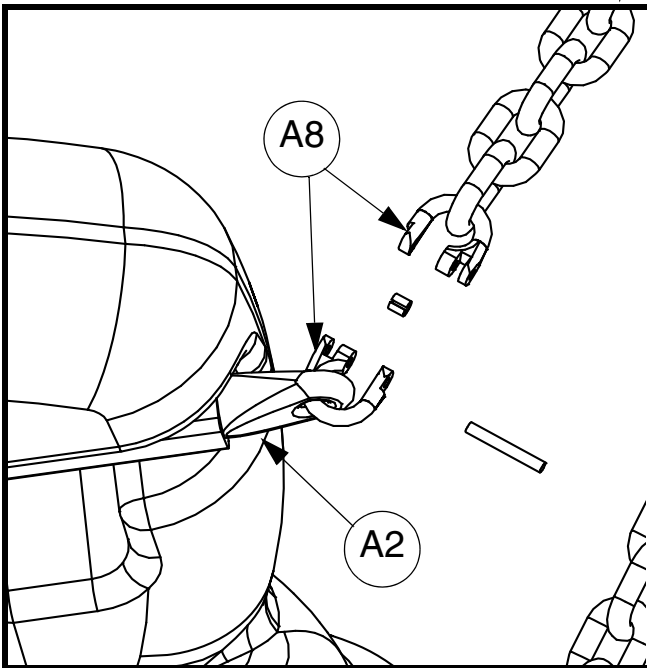
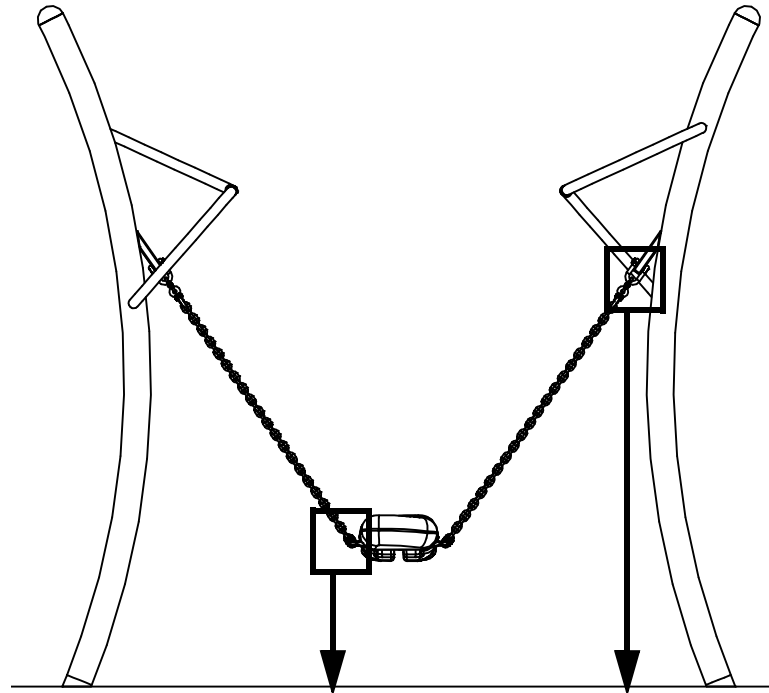

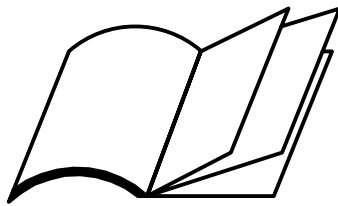

**Appendix B:**

**REF 37000101A**

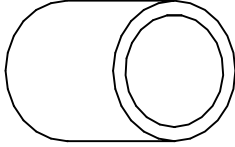
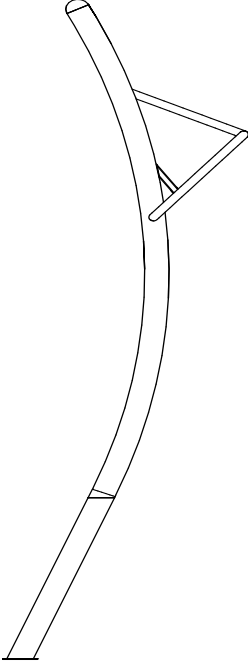
ITEM	REF		QTY.	WEIGHT (kg)
B1	15011612		1	0.002
B2	37000101		1	35.00

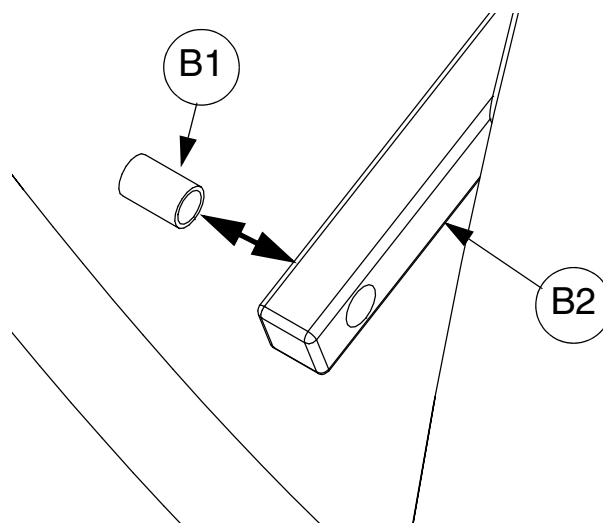

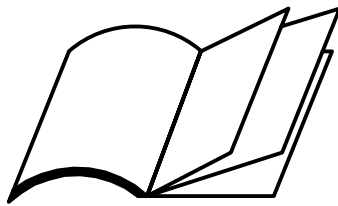

Appendix C:

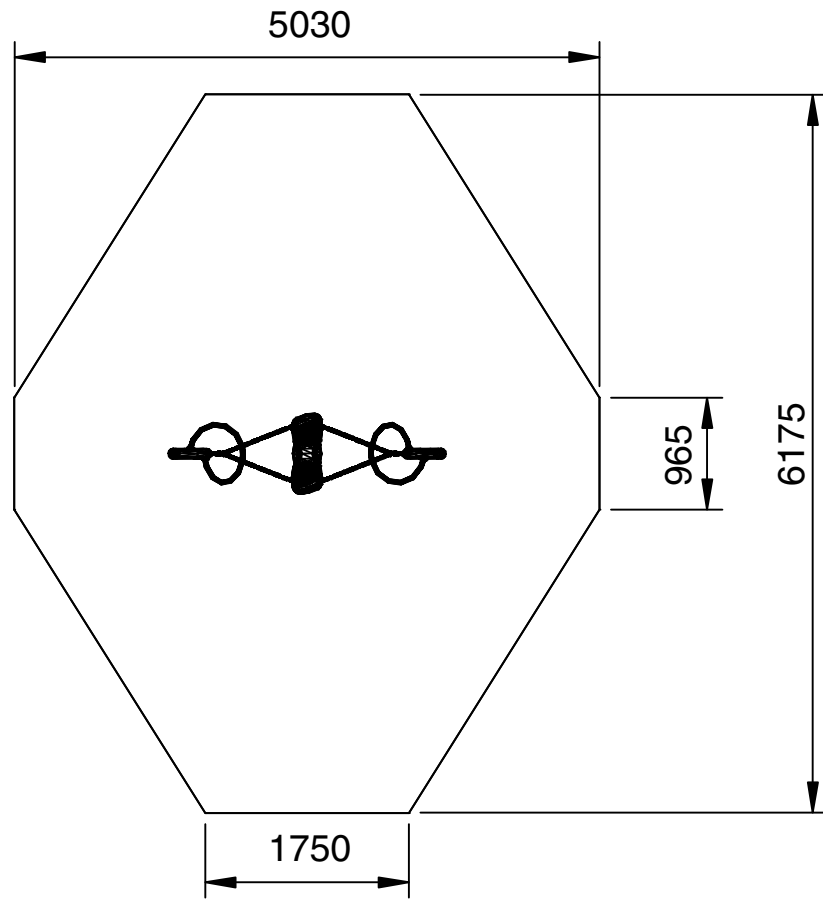

TYPE 2 LOOSEFILL

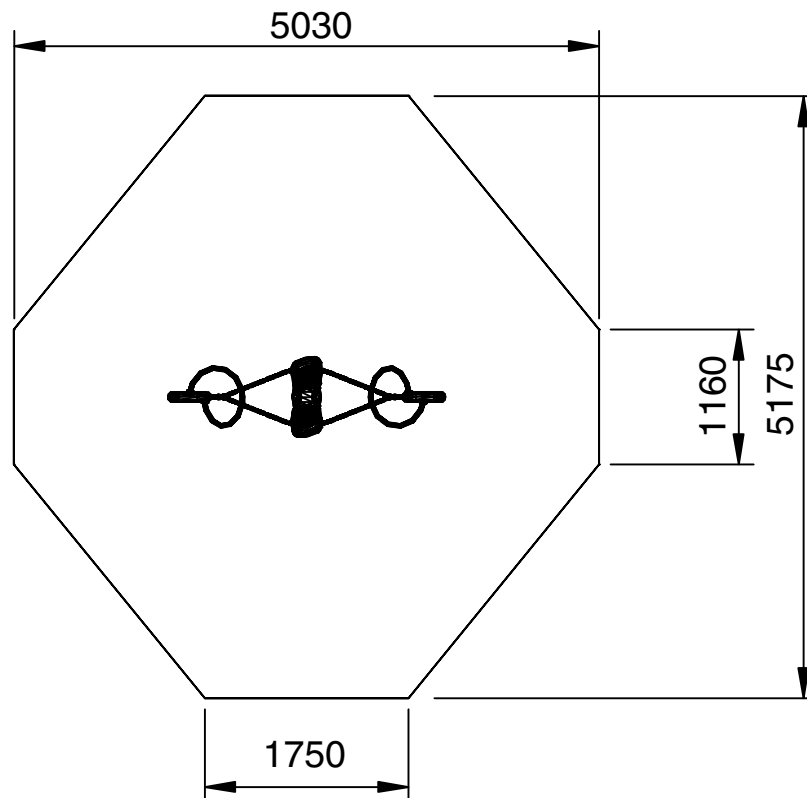

TYPE 3 SYNTHETIC

SMP Playgrounds Ltd. recommends an effective *Impact Absorbing Surface tested to EN1177 & BS7188* beneath **all** play equipment. Refer to manufacturers instructions for details of installation. The surface should have a Critical Fall Height greater than the Maximum Freefall Height of the equipment.

Care should be taken when siting this equipment in order to discourage users in the surrounding area from unintentionally coming into contact with the equipment. This can be achieved, for example by placing the equipment at the perimeter of the play area.

Constructional Space is the approximate working area required to layout and assemble the equipment.

For the safe operation of this equipment it must be installed on horizontal ground with the required minimum space.

If a loose fill surface is selected for this item it will require a very high level of maintenance to ensure a sufficient thickness is in place at all times to provide 'critical fall height' protection.

The concrete foundations indicated are for average ground. Care should be taken concerning abnormal conditions.

## 1 PREPARATION

All equipment assembly and fixings must conform to EN1176.

Before commencing the installation the surrounding area must be sufficiently fenced and signs erected to warn the public of the risk of injury.

**Tools / ancillary equipment:** Plumblines, 10m tape measure, Spirit level, Torque wrench, M10 Torx tool (Supplied with unit), Loose fill: Masking tape, paint brush, Black paint.

**Installation aids:-** To aid the support and positioning of the structure during installation it is recommended that a suitable temporary wooden tie bar and wooded props are constructed. See step 1 for temporary wooden tie bar details. Suitable M10 fixing bolts are required for wooden tie bar.

**Minimum Personal Protective Equipment:-** Hard hat, Gloves, Armoured boots, Goggles.

### 1.1 ESTABLISH ORIENTATION

- i) See Specifications for equipments 'Minimum space'.
- ii) Measure out the site to ensure the space required fits into the allotted area, it is horizontal and free from trip points or other obstructions.
- iii) Ensure the equipment is to be provided with an effective Impact Absorbing Surface which has a tested critical fall height rating greater than the maximum freefall height of the equipment.

### 1.2 MARK OUT HOLES

Consult SMP layout drawing for structure position on site.

See page 3 for concrete foundation spacings.

**NOTE:** This is a minimum guide only. Hole excavation should be done progressively as the steelwork is erected.

### 1.3 ESTABLISH DATUM LEVEL

- i) If a rubber tiled Impact Absorbing surface is to be laid, see separate instructions (base may incorporate up to 2% falls etc.).
- ii) If equipment is to sit in loose fill or wet pour rubber surfaces allowances will need to be made for its recommended thickness. With certain loose fill materials, a greater thickness than 300mm may be required. This will need to be determined by allowing 100mm for dispersal in addition to the thickness required for the freefall height of the particular Nexus layout. If the installation is with a loose-fill type surface, the structure should be marked with a 'Basic Level Mark' to indicate the recommended 'Finished Surface Level' of the surface. Using masking tape, paint a 10mm wide mark around each leg with black paint.

## 2 INSTALLATION & ASSY PROCEDURES

### 2.1 SAFE WORKING PRACTICE:

A full risk assessment should be carried out prior to commencing the installation, which will be specific to the site selected. The major risks associated with purely the assembly of this product are highlighted below, which can form part of this overall assessment.

### 2.2 RISKS:

- i) Large parts which could be difficult to lift or handle.
- ii) Structure unstable until concrete footings have fully cured.

### 2.3 CONTROL MEASURES:

- i) All staff working on installation to wear suitable PPE including Toe Protective Shoes and Gloves.
- ii) Any staff or other persons on site, not working directly on the installation, to be kept away from the installation.
- iii) Ensure adequate personal and equipment are on site to handle and support the structure whilst it is being assembled.

### Pre - Installation Inspection:-

- i) Inspect all parts for damage (that may have occurred during transportation & storage). Finish Coatings, if found to be damaged these should be made good before erection (Refer to maintenance instructions). Any damaged or missing parts must be replaced.
- ii) Warn the public of the risk of injury, by placing signs and fencing the surrounding area, before commencing installation.

## 3 INSTALLATION

- i) Refer to site layout for position and orientation of product, then, mark the outline of the position of the footings with e.g. spray or chalk etc. Excavate the holes. **See page 3.**
- ii) Position a post (item 1) into the excavation referring to the site layout, shim as required and check its position and orientation. Ensure the post is plumb and square. Use suitable props to hold leg safely in position.
- iii) Position a second post (item 1) into excavation and use a temporary wooden tie bar (not supplied) as shown to correctly space top of legs into position. Shim as required, checking its position and orientation to the first post. Use suitable props to hold leg safely in position. **(STEP 1).**

**NOTE: It is very important to check that the legs are in correct relative position to ensure the correct assembly of the Seat & Chain Assembly at a later time. Measure between the pivot centres on the legs, and the height of the pivot centre to the 0.0 level See (STEP 1).**

Concrete mix is recommended at:  
1 part cement;  
2 parts sand;  
4 parts aggregate;  
by volume with 20mm aggregate  
(20 N/mm<sup>2</sup> min compressive strength)

**NOTE: Check that the completed structure has been positioned in the correct place and that it is plumb and square. Also ensure that the structure is propped safely so that it may be left for the concrete foundations to cure.**

- iv) Fill the holes with concrete to the required level, taking into account any Impact Absorbing Surfacing requirements. Ensure that a full volume of concrete is used. The top of the concrete should gradually (1:100) slope down & outwards locally from the equipment upstand to the required level to form a watershed.

- v) Keep installation off limits to the public until the concrete has completely cured. (Recommended initial curing time is 48 hours).
- vi) If the installation is with loose fill type surface, the support legs should be marked with a 'Basic Level Mark' to indicate the recommended Finished Surface Level of the surface.
- vii) Remove temporary wooden tie bar and attach Seat & Chain Assembly (item 2) to each post by sliding shackle bolt through the shackle and the pivot bush. Hand tighten shackle bolt so that hole in the bolt aligns with the hole in the shackle and then fit the Sel-Lok-Pin. **(STEP 2)**.
- viii) In all fixing positions on the steel work that have not been utilised, the protective plug should be removed and the permanent black protective plug (item 3) inserted & knocked home with a soft hammer. **(STEP 3)**

#### 4 POST INSTALLATION INSPECTION

CHECK	CHECK	✓
1 All fixings are tightened to a maximum torque setting of 20-25Nm and have no protruding sharp edges.	<input type="checkbox"/>	
2 Paint work is not damaged (Any making good should be carried out using the procedure in the Inspection and Maintenance instructions).	<input type="checkbox"/>	
3 Sel-Lok-Pins are inserted.	<input type="checkbox"/>	
4 Swing Shackles move freely.	<input type="checkbox"/>	
5 Concrete foundations are secure.	<input type="checkbox"/>	
6 Concrete has a water shed away from legs.	<input type="checkbox"/>	
7 Adequate provision of impact absorbing surfacing and no trip points within the minimum space.	<input type="checkbox"/>	
8 Site is clear of all tools and rubbish.	<input type="checkbox"/>	
9 Remove any warning signs.	<input type="checkbox"/>	
10 Loose fill surfacing only: The Basic Level Marks have been painted onto the legs.	<input type="checkbox"/>	
11 Ensure all unused fixing holes in steel work have the correct black plastic plug fitted.	<input type="checkbox"/>	