



## INSTALLATION INSTRUCTIONS

# NEXUS

## VELOCITY 8



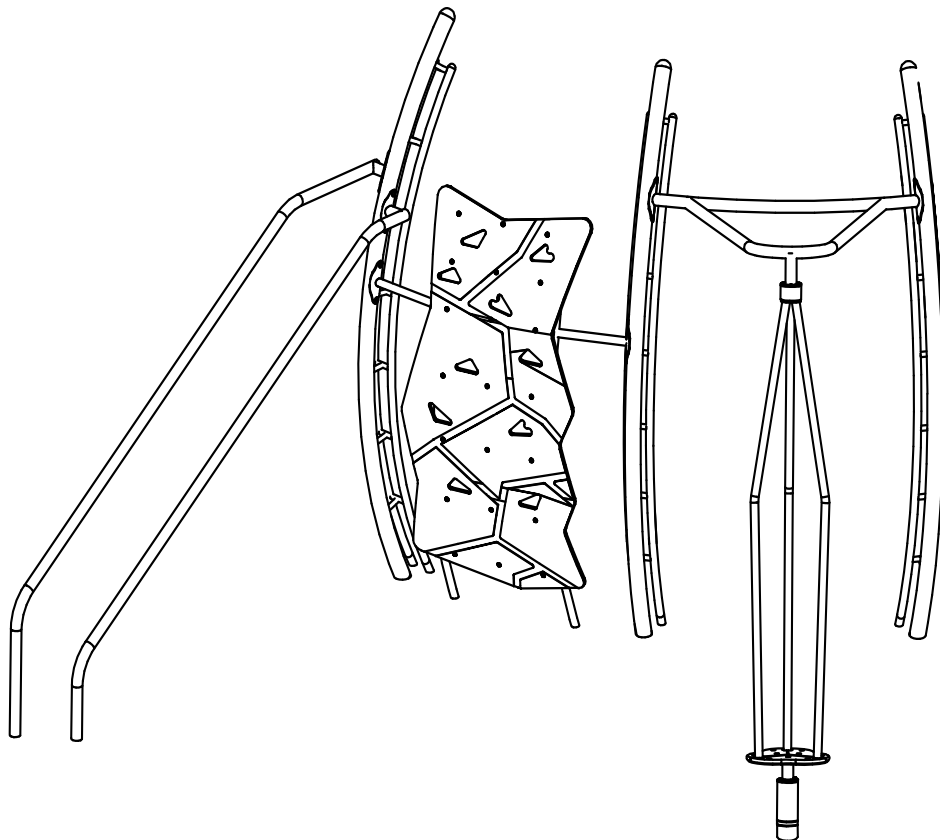

### NXVS8 NXVE8

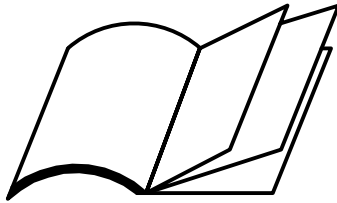

NO PART OF THIS MANUAL OR DOCUMENT MAY BE COPIED OR RE-PRODUCED IN ANY FORM OR BY ANY MEANS WITH OUT THE EXPRESS WRITTEN PERMISSION OF SMP (PLAYGROUNDS) LTD.

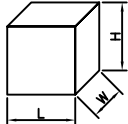
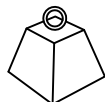
email: [sales@smp.co.uk](mailto:sales@smp.co.uk)  
[www.smp.co.uk](http://www.smp.co.uk)

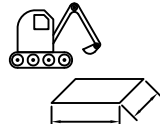
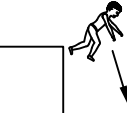

						
	LxWxH (m)	kg	m <sup>3</sup>	m	≥EN1176	x 3= T
<b>NXV*8</b>	3.23 x 4.63 x 3	609	2.25	8.00 x 9.00	2.5	T=48h

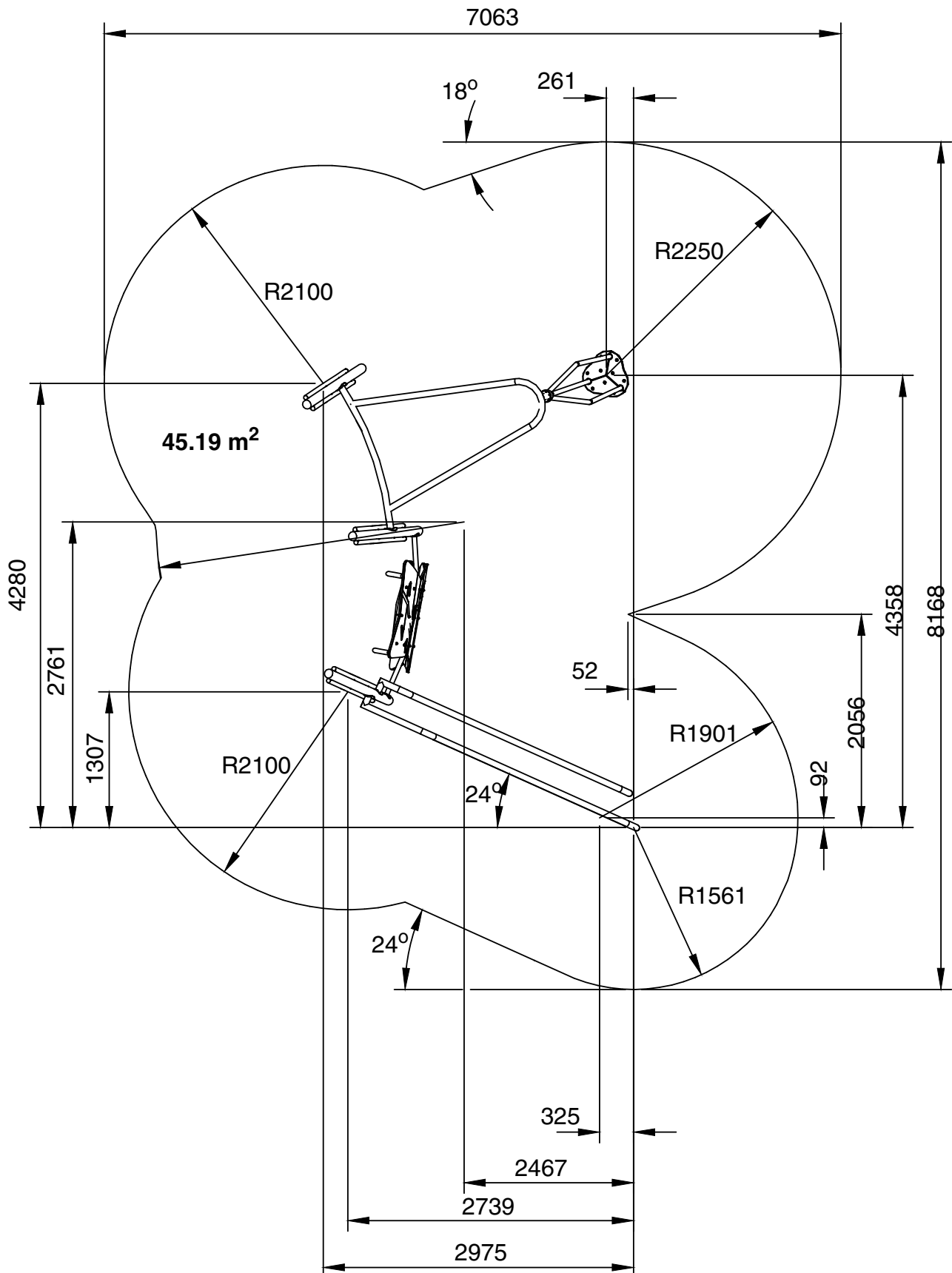

# NXVE8

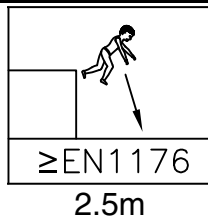
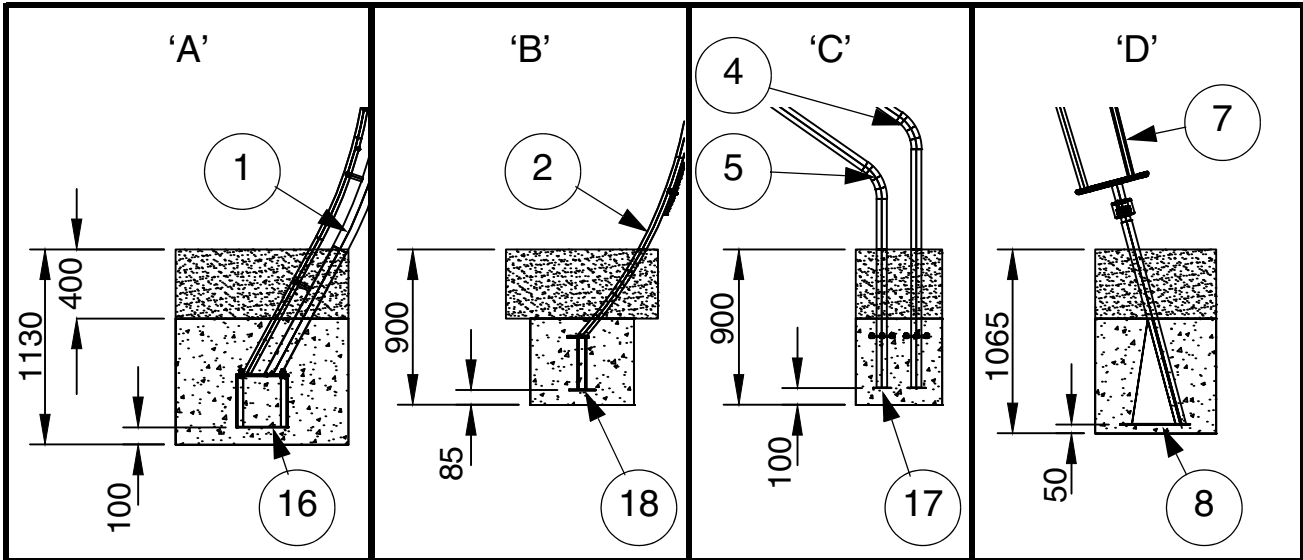

TYPE 2

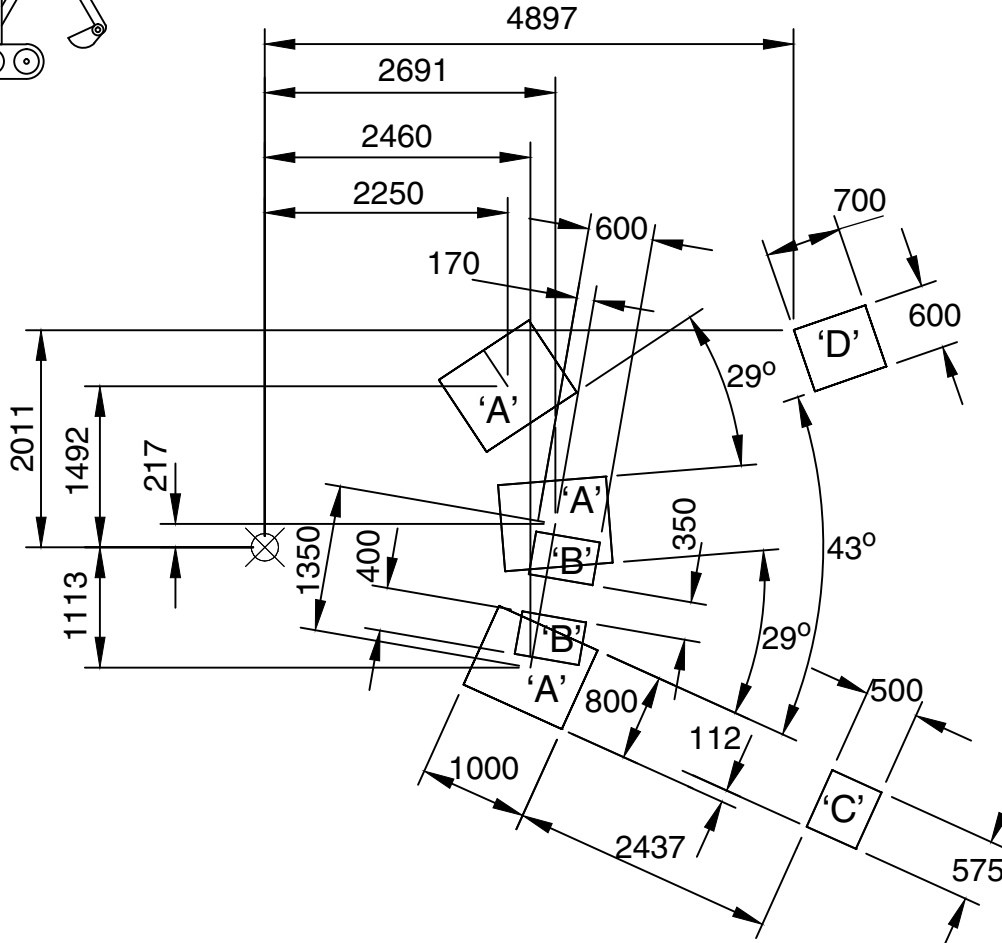
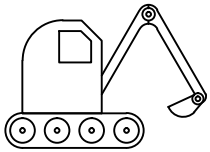
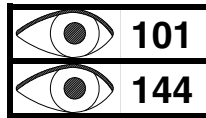

# NXVS8

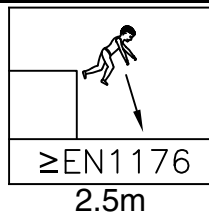
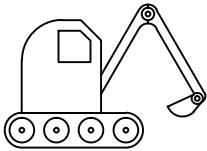
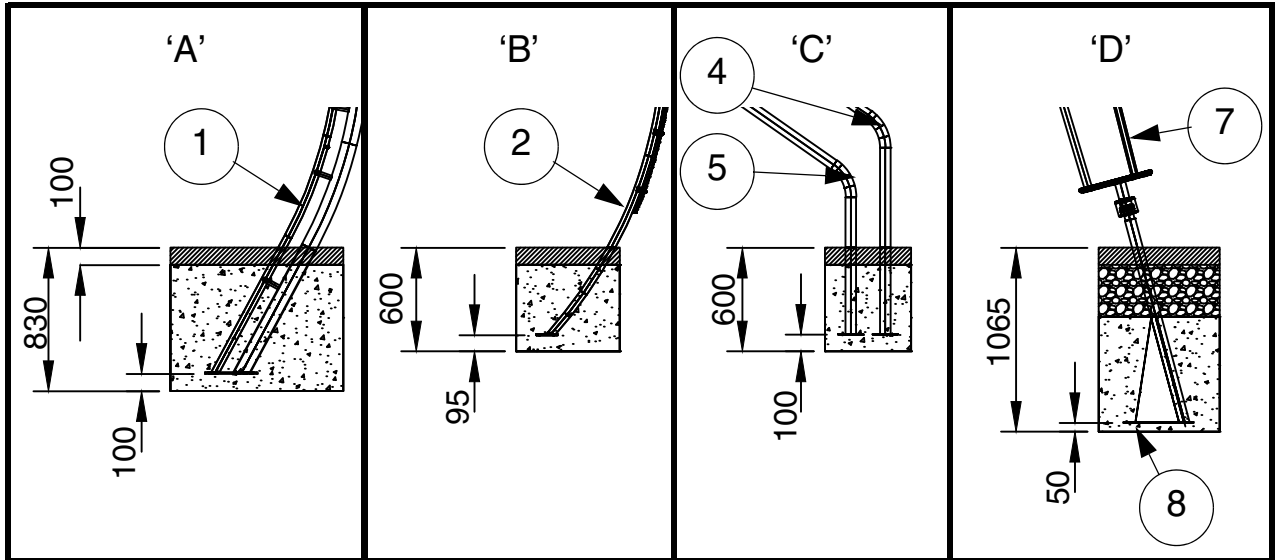





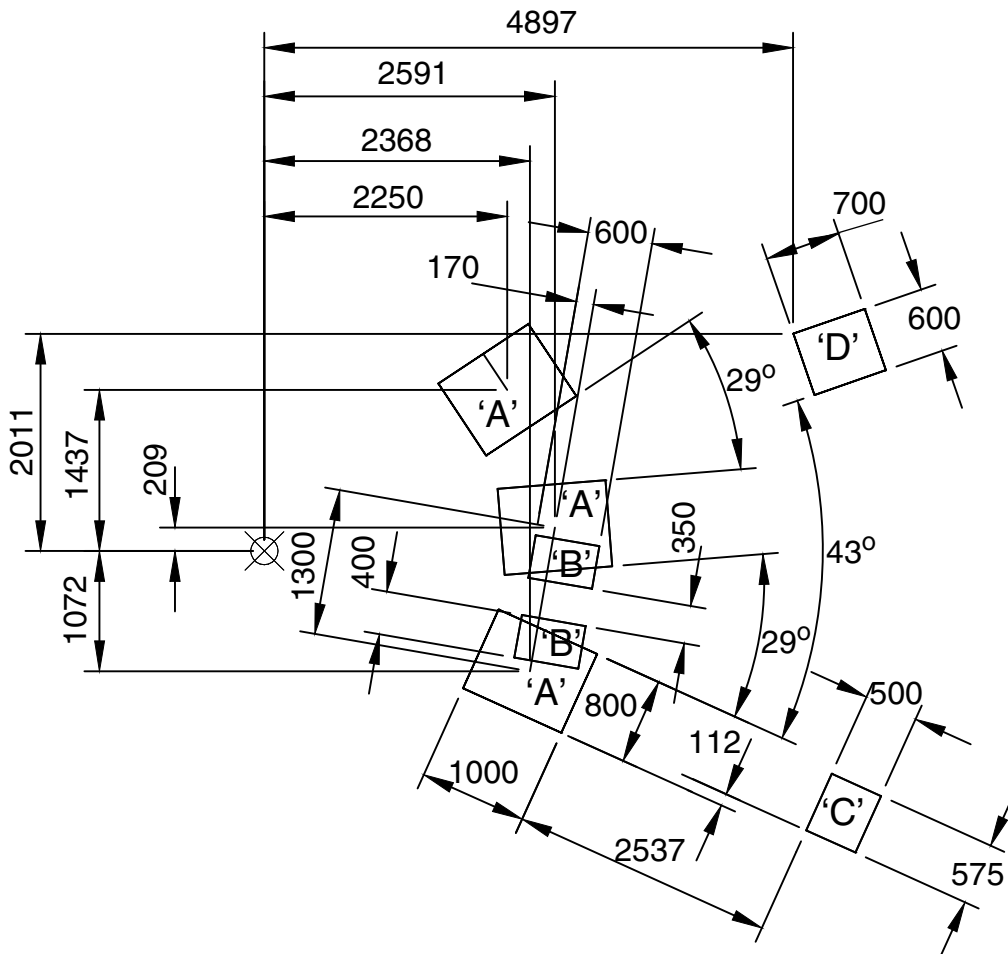

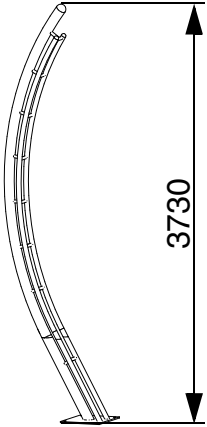
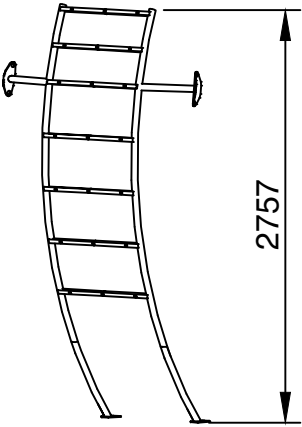
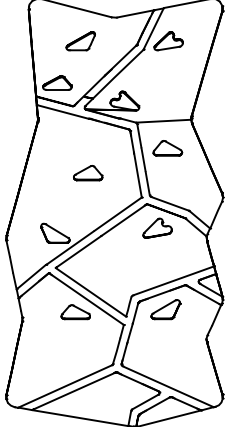
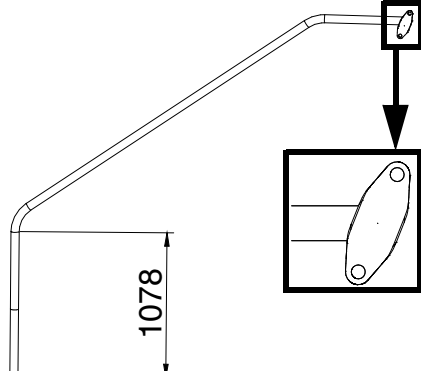
**TYPE 3**

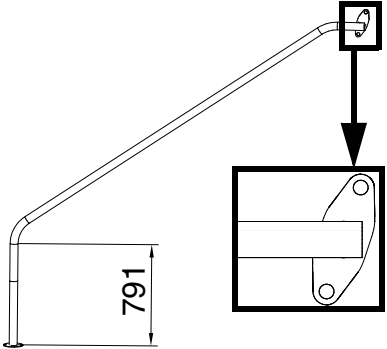
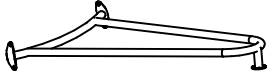
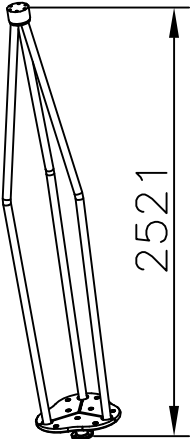
	<b>101</b>
	<b>144</b>

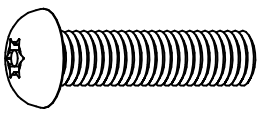
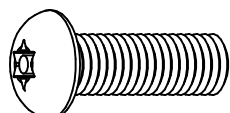

ITEM	REF.		NXVS8	NXVE8	kg
1	38000001		3		66.000
2	38006010		1		32.000
3	38006020		1		33.000
4	38002070		1		19.000

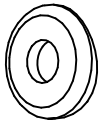
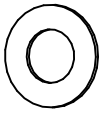
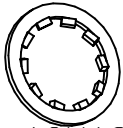
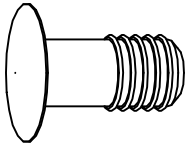
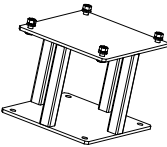
ITEM	REF.		NXVS8	NXVE8	kg
5	38002080		1		17.500
6	38007010		1		38.000
7	38007030		1		43.500
8	38007070		1		41.000
9	10121040	 M10 X 40	33		0.037
10	10121030	 M10 X 30	12		0.032
11	19023801		6		0.080

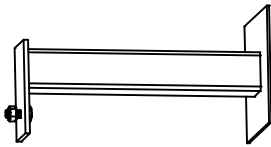
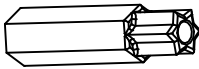
ITEM	REF.		NXVS8	NXVE8	kg
12	38001019	 M10 12X32X6.5	12		0.002
13	10291000	 M10 11X21X1	12		0.002
14	10301000	 M10 12X18X1	45		0.002
15	19024501		54		0.001
16	38000002			3	26.000
17	EPLUG			2	3.000
18	SSGIL			2	2.200
19	10121000	 T45 M10	3		-

# STEP 1

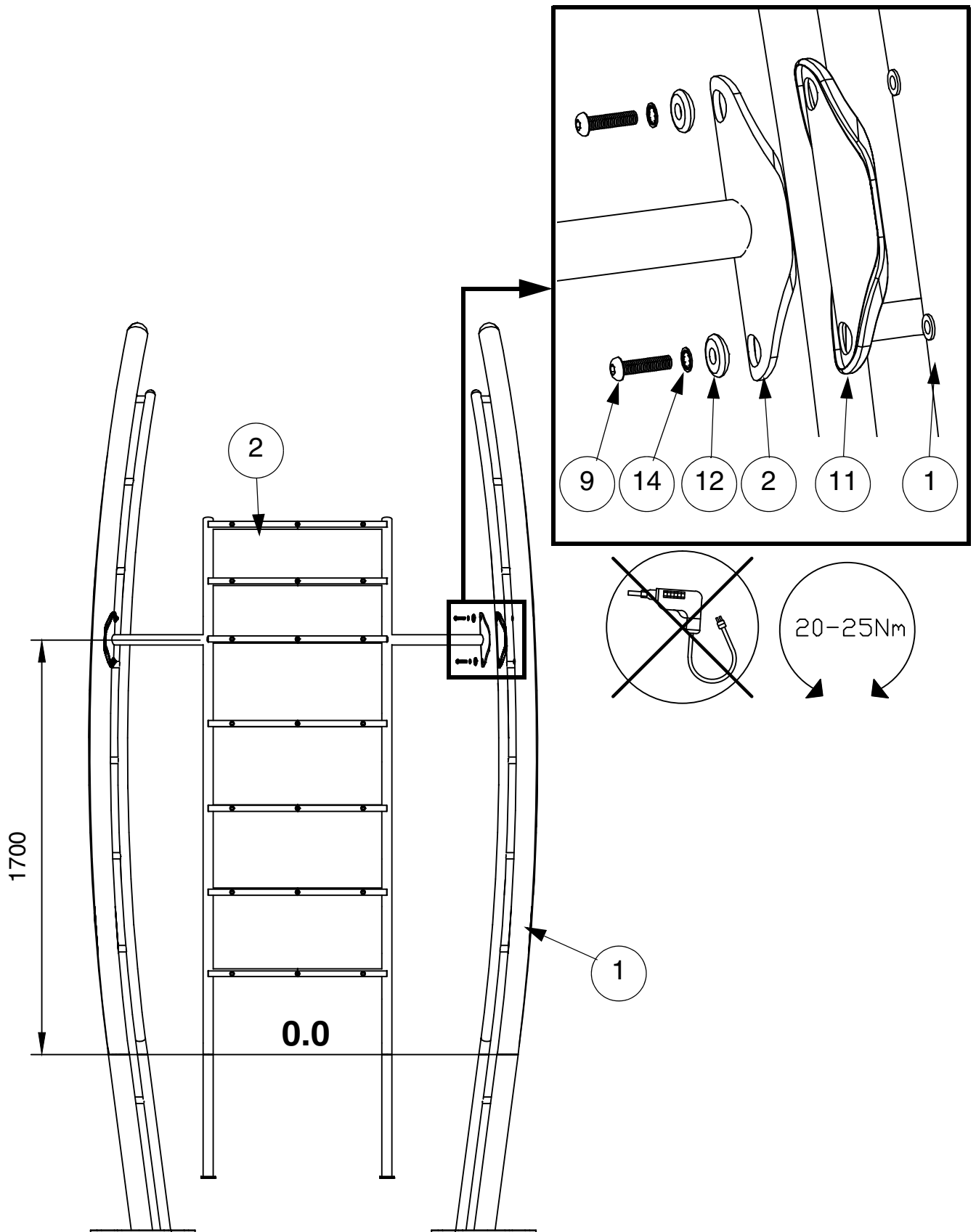

# STEP 2

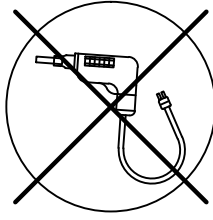

20-25Nm

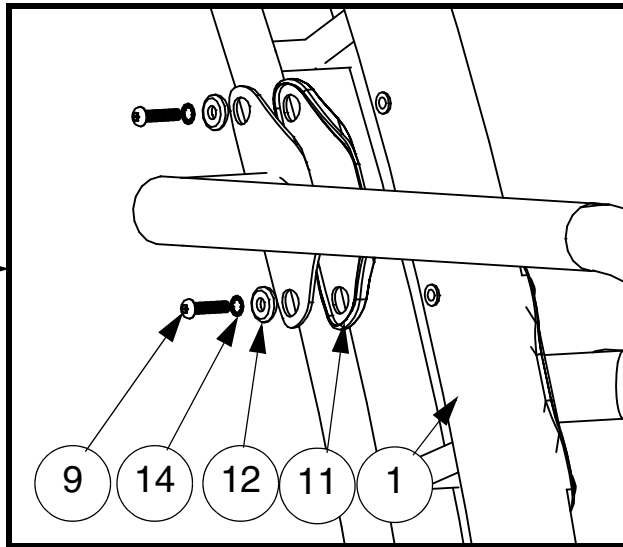

x 2

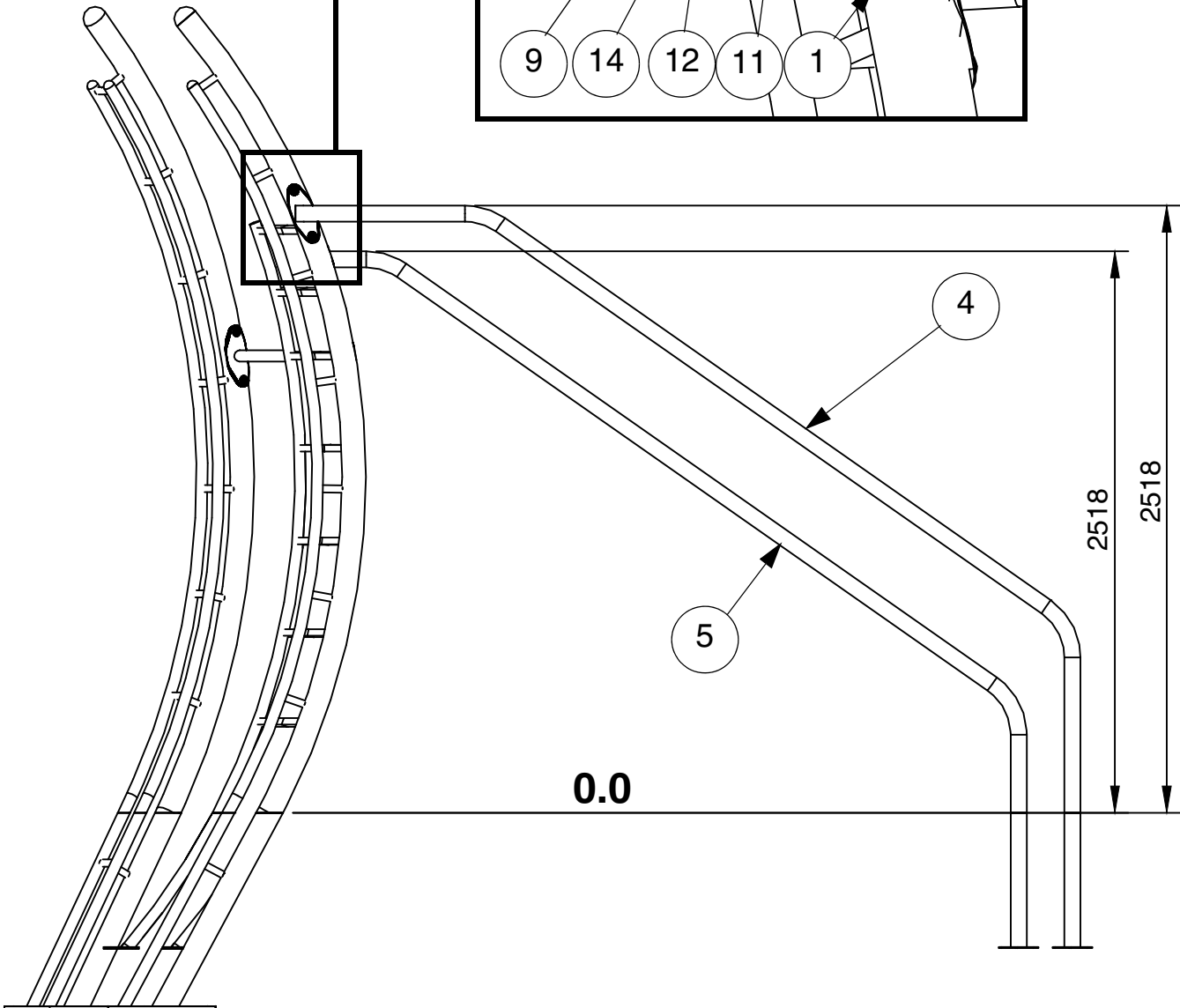

# STEP 3

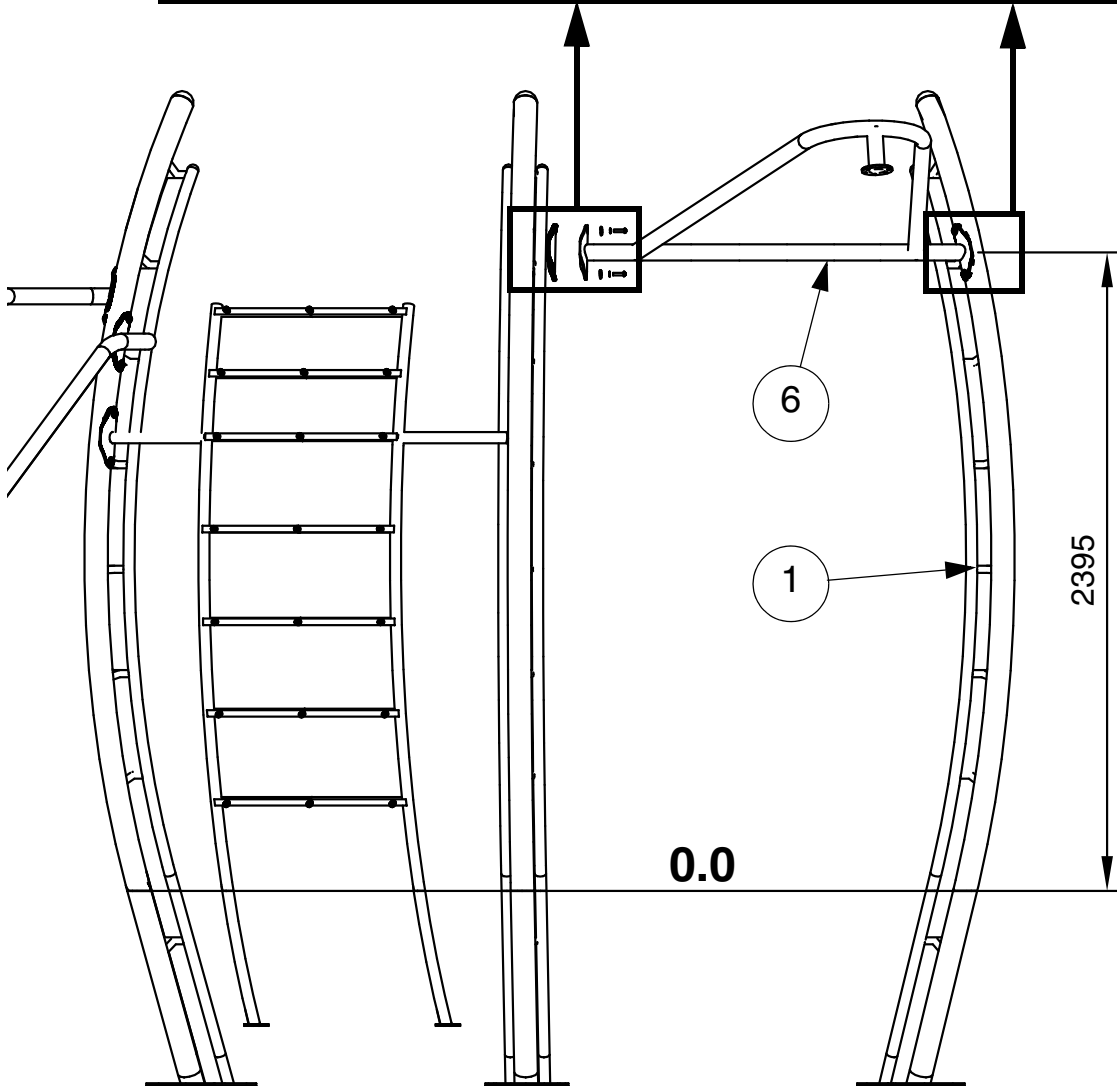
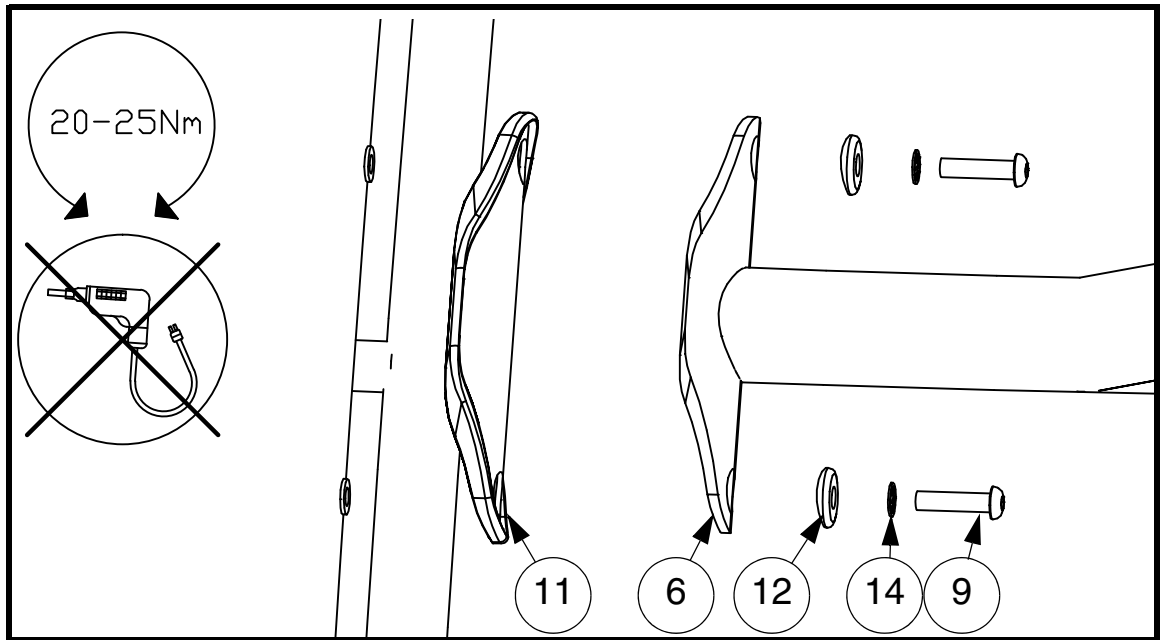

# STEP 4

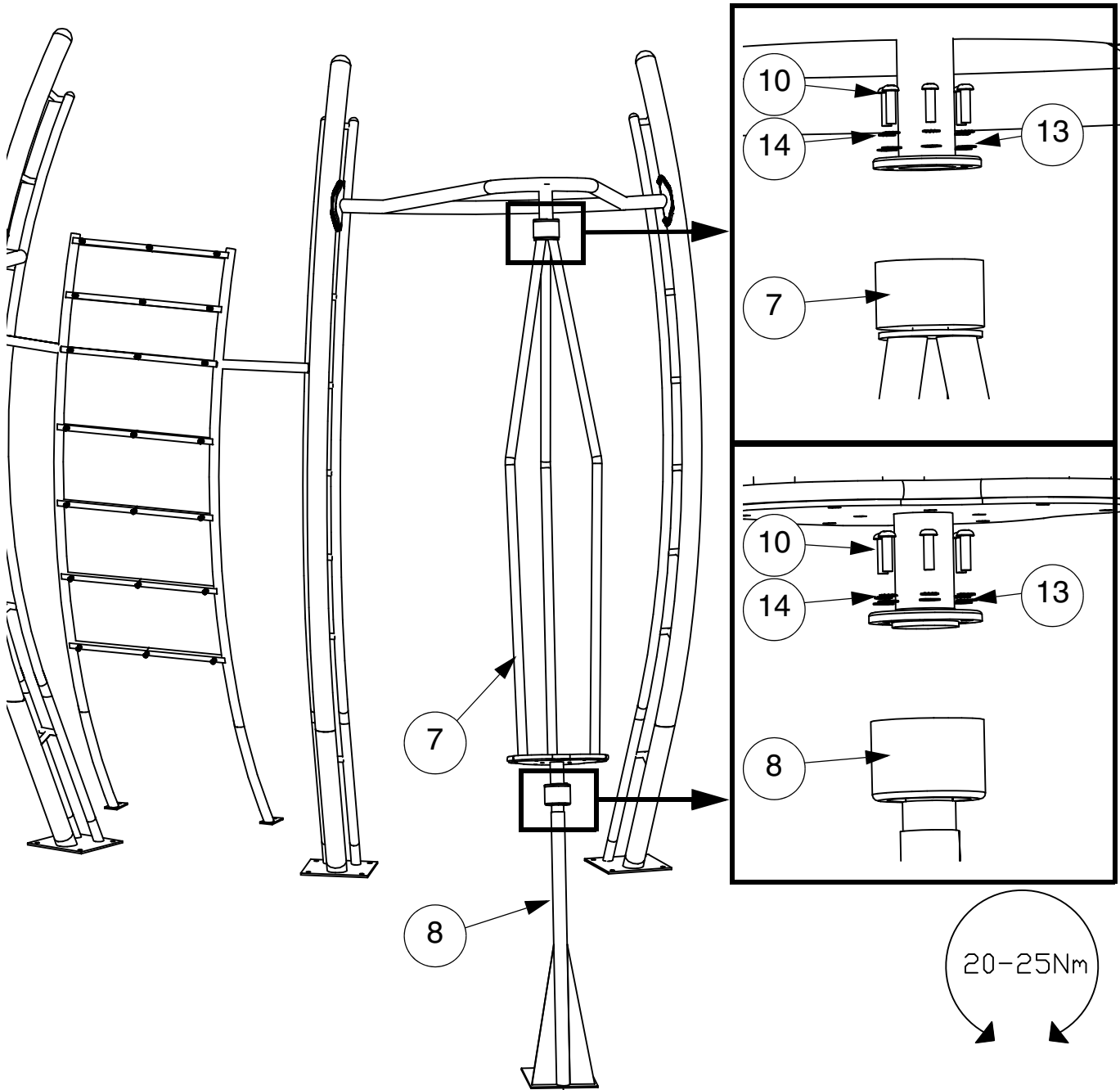

# STEP 5

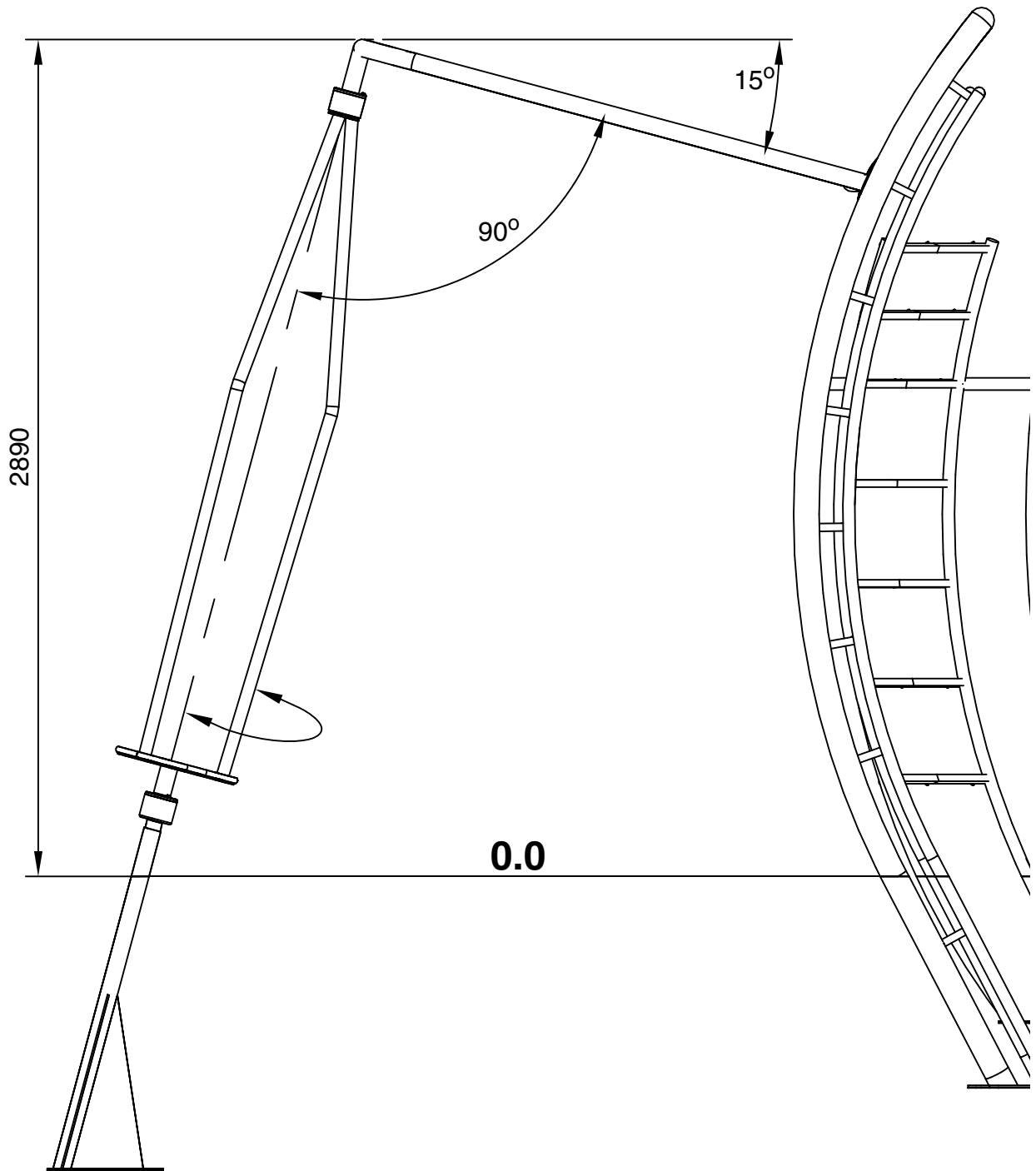
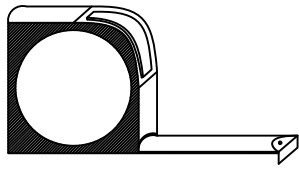

# STEP 6

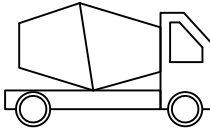

S2 (50mm)
≥C20-25
🕒 7 x 24h
👁️ 101

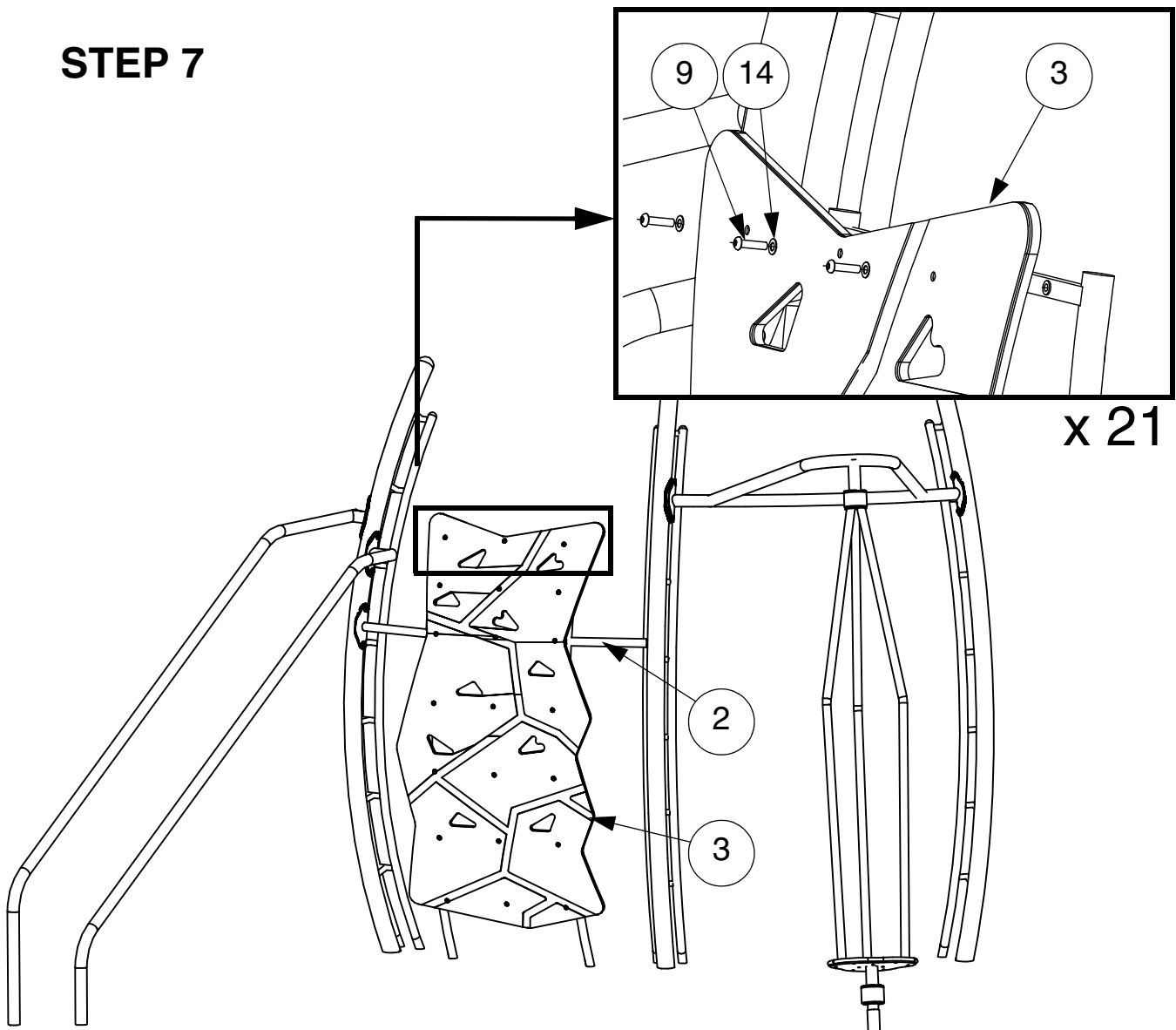

# STEP 7

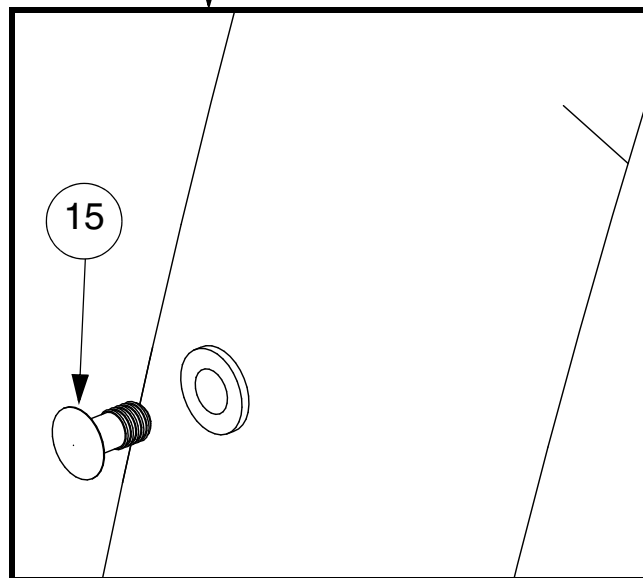
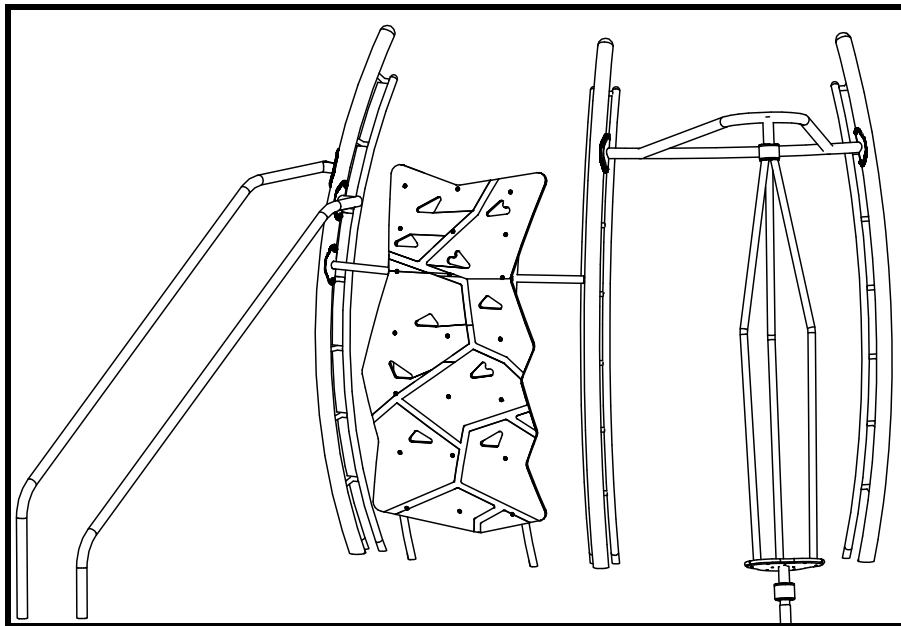

# STEP 8



x 54

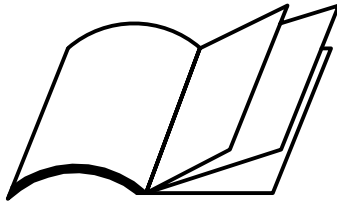

## Appendix A:

## REF 38007030

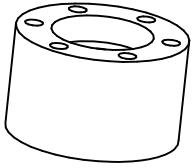
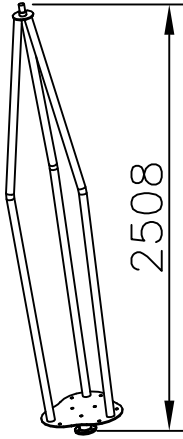
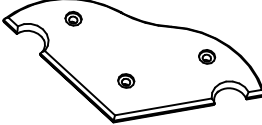
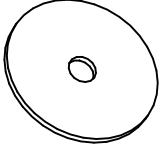
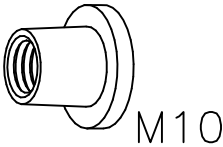
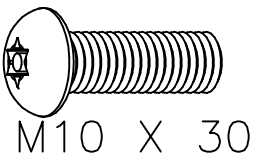
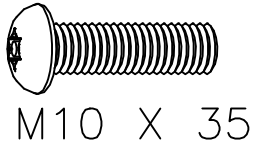
ITEM	REF		QTY.	kg
A1	38007031		1	5.000
A2	38007034		1	35.000
A3	38007039		3	1.000
A4	38007054		1	0.080
A5	10931000		9	0.006
A6	10121030		1	0.028
A7	10121035		3	0.032

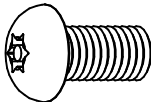
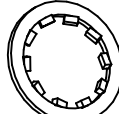
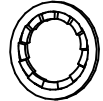
ITEM	REF		QTY.	kg
A8	10121020	 M10 X 20	6	0.020
A9	10301000	 M10 12X18X1	10	0.002
A10	10301200	 M12 13X20X1	9	0.002

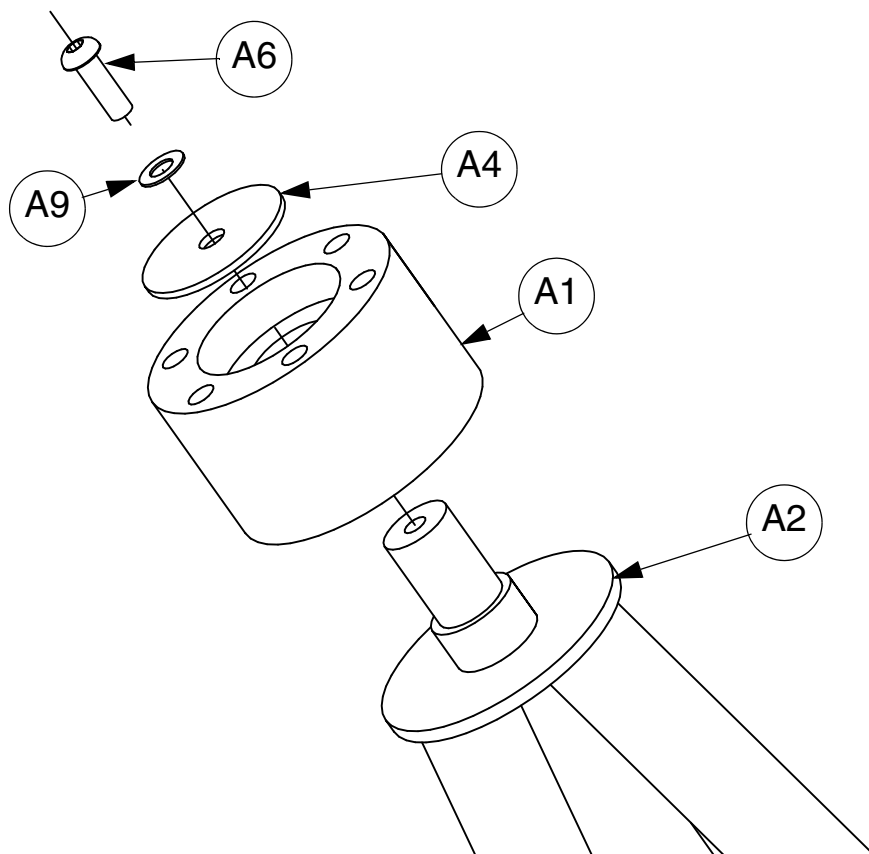

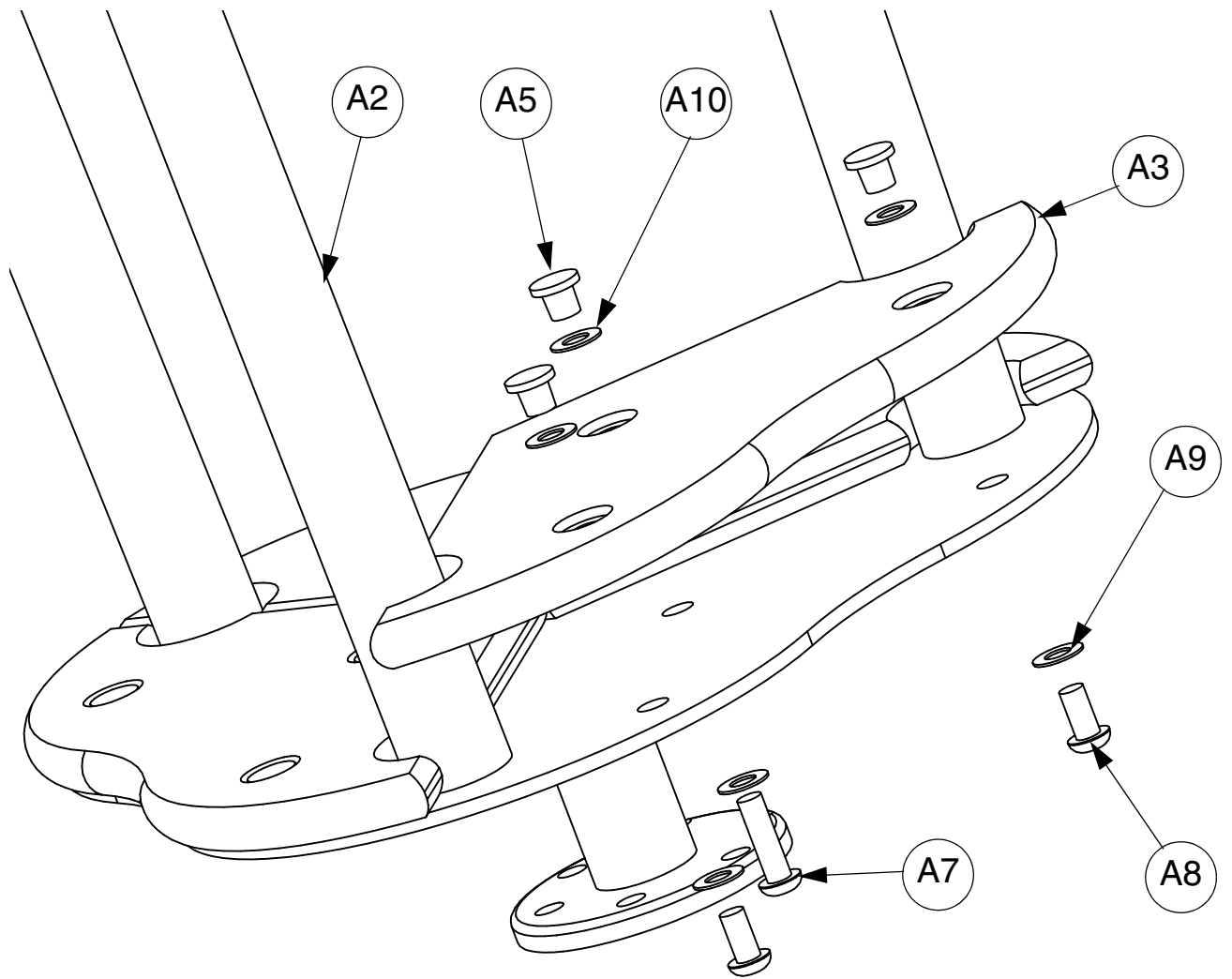

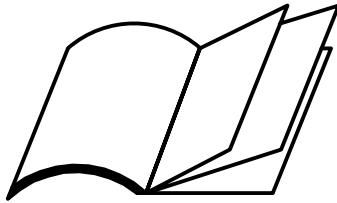

**Appendix B:**

**REF 38007031**

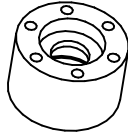
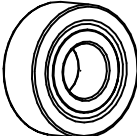
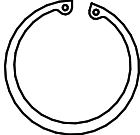
ITEM	REF		QTY.	kg
B1	38007032		1	4.500
B2	38007033		1	0.510
B3	10060072		1	0.001

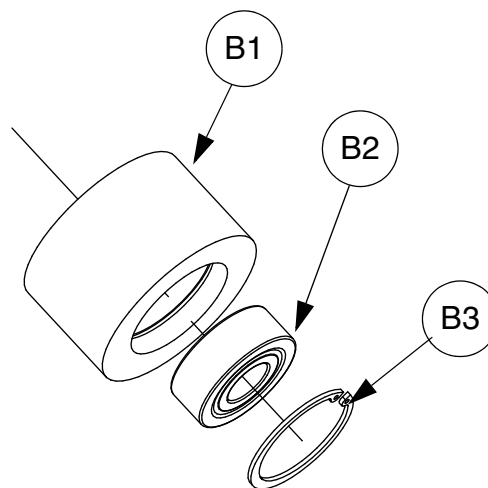

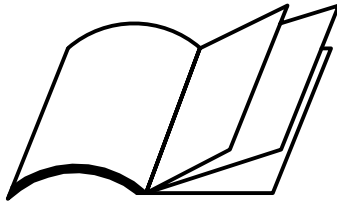

## Appendix C:



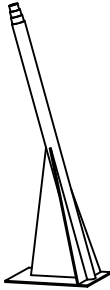
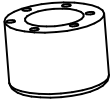
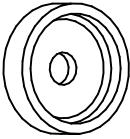
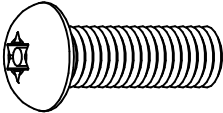
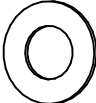
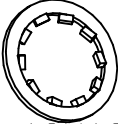

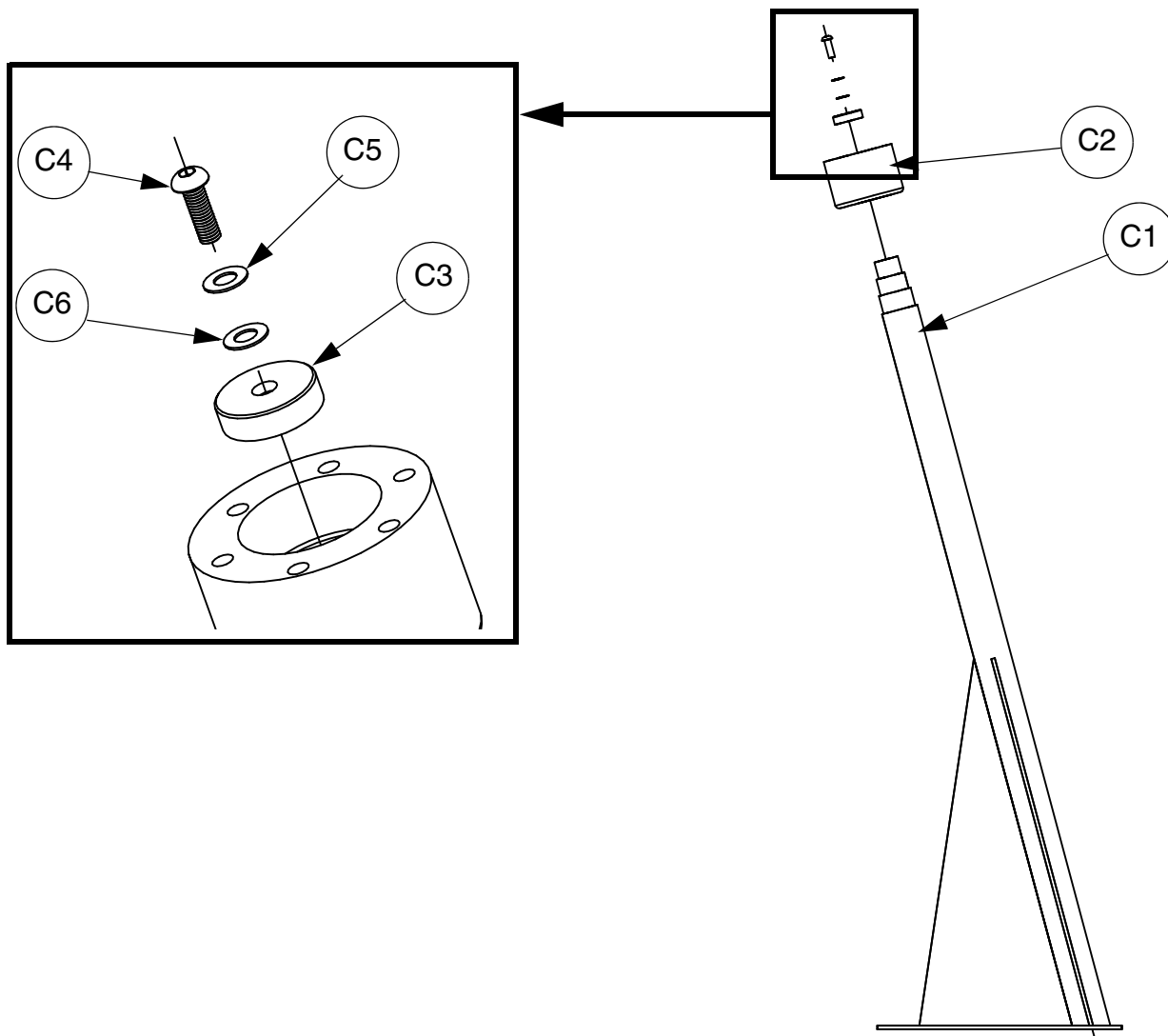
### REF 38007070

ITEM	REF.		QTY	kg
C1	38007071		1	32.000
C2	38007074		1	7.000
C3	38007073		1	0.100
C4	10121030	 M10 X 30	1	0.028
C5	10291000	 M10 11X21X1	1	0.002
C6	10301000	 M10 12X18X1	1	0.002

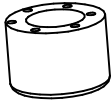

**Appendix D:**

**REF 38007074**

ITEM	REF.		QTY	kg
D1	38007082		1	7.000
* D2	71022208		1	0.520
D3	38007076		1	0.015
D4	10060032		1	0.010

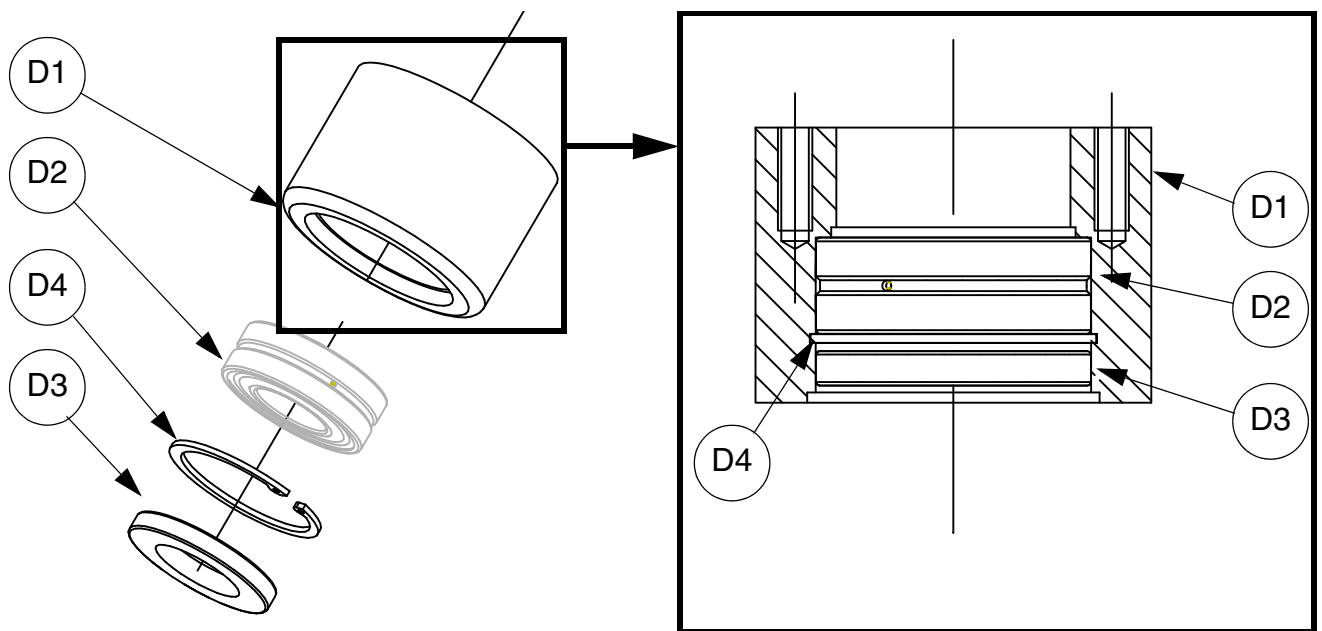

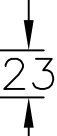
* D2	38007075	 	1	0.520
---------	----------	--	---	-------

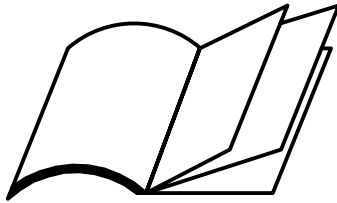

Appendix E:

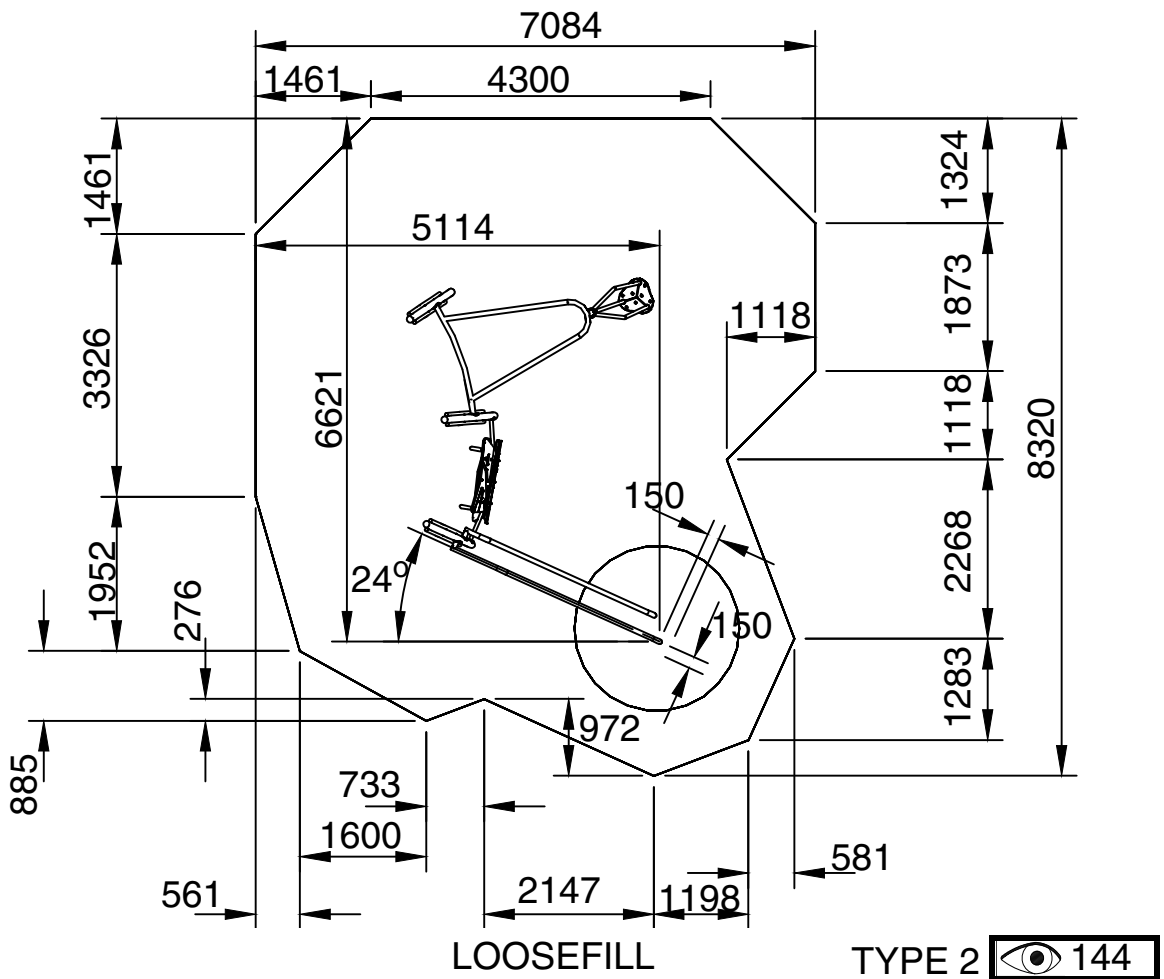
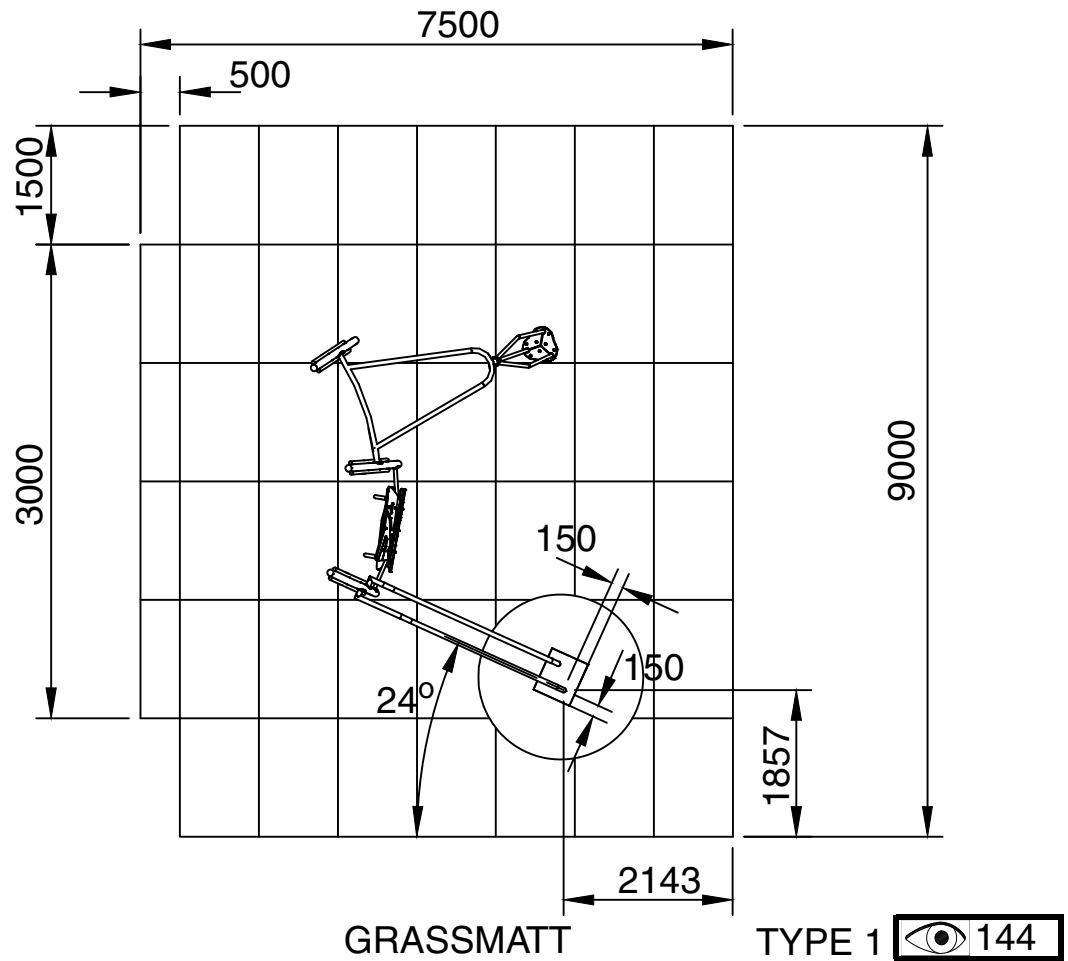

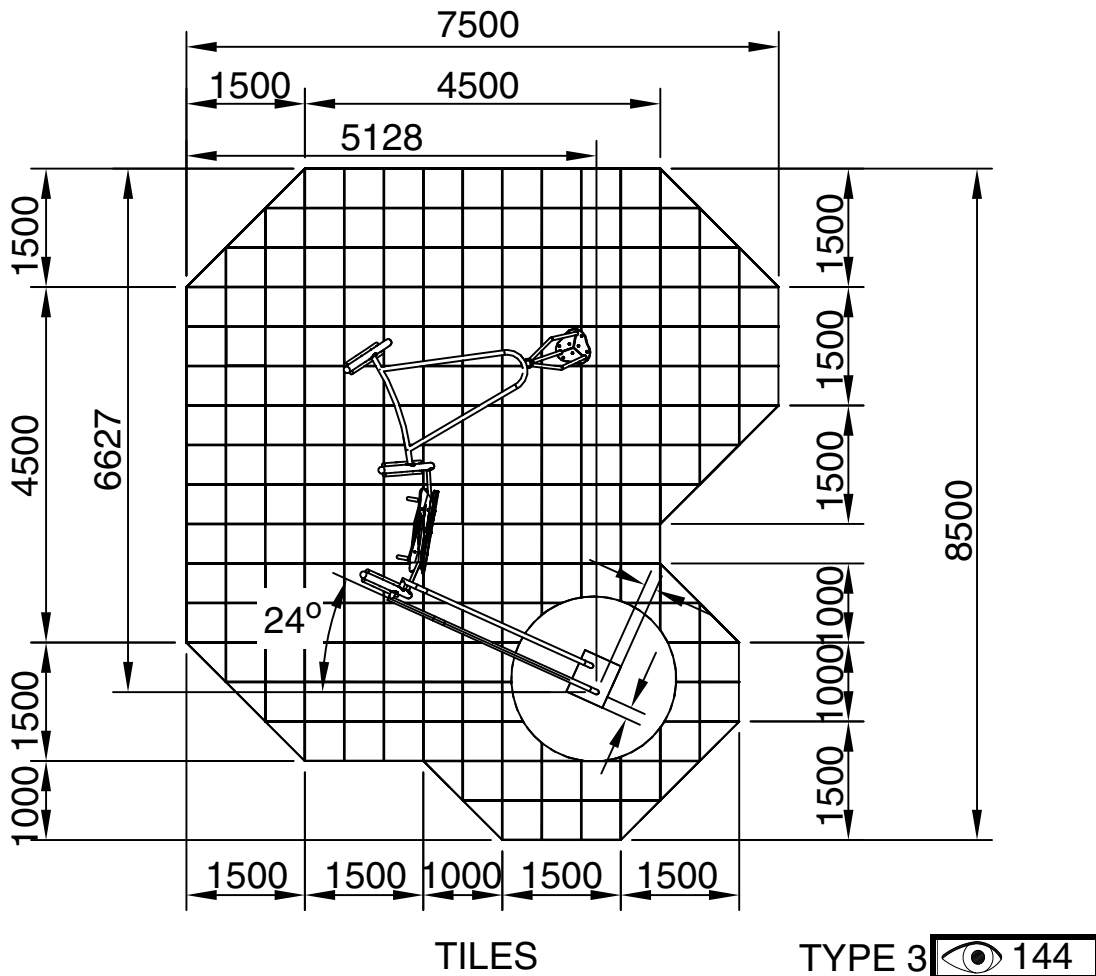
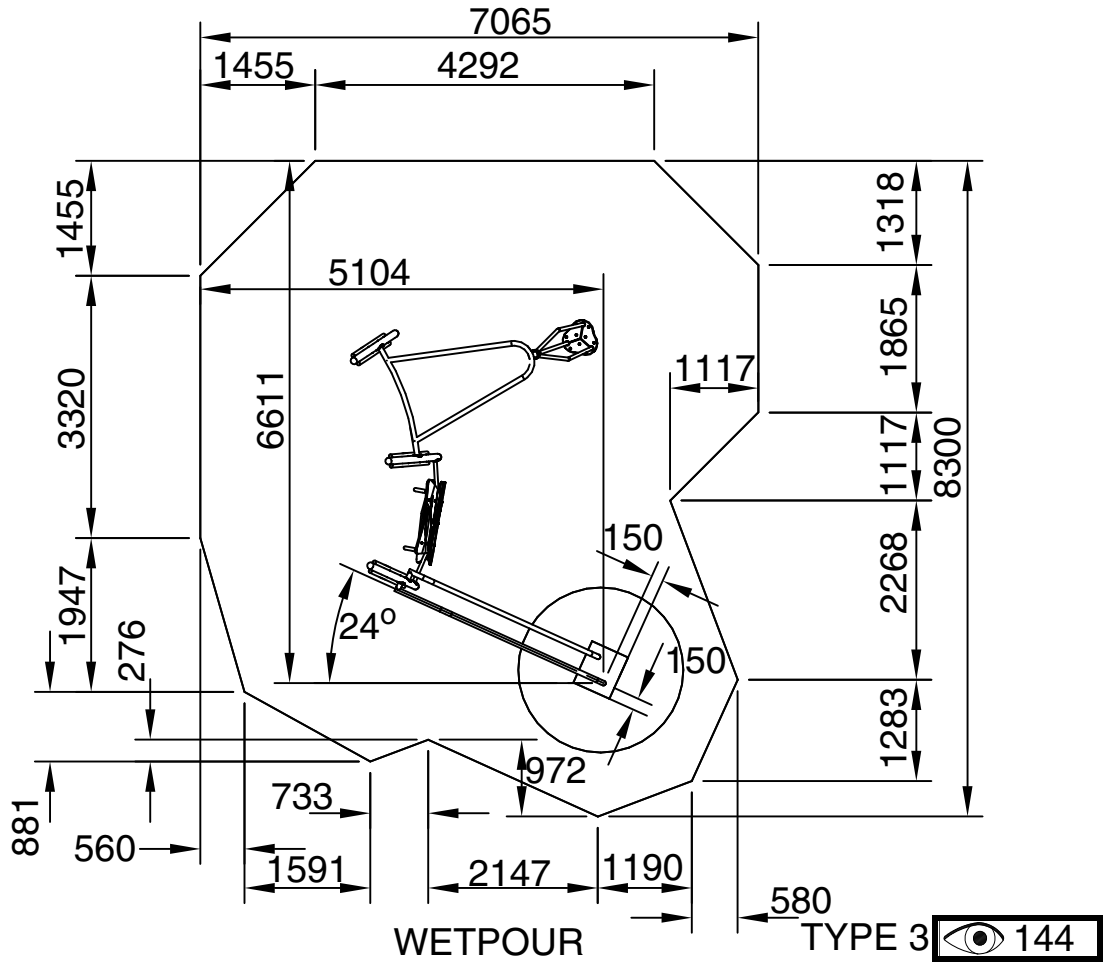

SMP Playgrounds Ltd recommends an effective *Impact Absorbing Surface tested to EN1177 & BS7188* beneath this play equipment. Refer to manufacturers instructions for details of installation. The surface should have a Critical Fall Height greater than the Maximum Freefall Height of the equipment. Subject to a risk assessment & for certain Fall Heights a grass surface may be used.

Constructional Space is the approximate working area required to lay out and assemble the equipment.

Care should be taken when siting this equipment in order to discourage users in the surrounding area from unintentionally coming into contact with the equipment. This can be achieved, for example by placing the equipment at the perimeter of the play area.

For the safe operation of this equipment it must be installed on horizontal ground with the required minimum space.

If a loose fill surface is selected for this item it will require a very high level of maintenance to ensure a sufficient thickness is in place at all times to provide 'critical fall height' protection.

The concrete foundations indicated are for average ground. Care should be taken concerning abnormal conditions.

**Tools:** 5m tape measure, Spirit level, M10 Torx tool (Supplied with unit), 19mm A/F Socket, Extension bar, Torque wrench.

## 1 INSTALLATION & ASSY PROCEDURES

### 1.1 SAFE WORKING PRACTICE:

A full risk assessment should be carried out prior to commencing the installation, which will be specific to the site selected. The major risks associated with purely the assembly of this product are highlighted below, which can form part of this overall assessment.

### 1.2 RISKS:

- i) Large parts which could be difficult to lift or handle.

### 1.3 CONTROL MEASURES:

- i) All staff working on installation to wear suitable Toe Protective Shoes and Gloves.
- ii) Any staff or other persons on site, not working directly on the installation, to be kept away from the installation.
- iii) Care should be taken when any awkward/heavy lifting may be required.

### Pre Installation Inspection:-

- i) Inspect all parts for damage (that may have occurred during transportation & storage). Finish Coatings, if found to be damaged these should be made good before erection (Refer to maintenance instructions). Any damaged or missing parts must be replaced.
- ii) Warn the public of the risk of injury, by placing signs and fencing the surrounding area, before commencing installation.

### 1.4 INSTALLATION

- i) Refer to site layout for position and orientation of product, then, mark the outline of the position of the footings with e.g. spray or chalk etc. Excavate the hole. **See Pages 4 & 5**
- ii) Attach climb wall frame (item 2) between the posts (item 1) using 2 off Gaskets (item 11), 4 off M10 x 40 Resistorx bolts (item 9), Saddle washers (item 12) and Shockproof washers (item 14). **(STEP 1)**
- iii) Attach top and bottom banister rails (Item 4 & 5) to left hand post (item 1) using 2 off Gaskets (item 11), 4 off M10 x 40 Resistorx bolts (item 9), Saddle washers (item 12) and Shockproof washers (item 14). **(STEP 2)**
- iv) Attach to top of post (item 1) and existing post, Spinner Support Beam (item 6) using 2 off Gaskets (item 11), 4 off M10 x 40 Resistorx bolts (item 9), Saddle washers (item 12) and Shockproof washers (item 14). Tighten all fixings to a maximum torque setting of 20-25Nm. **(STEP 3)**

- v) Attach base of spinner (item 7) to the bearing housing on the Spinner Ground Mounting Assembly (item 8) using 6 off M10 x 30 Resistorx bolts (item 10) M10 Washers (item 13) and M10 Shockproof Washer (item 14). Tighten the fixing bolts to a maximum torque setting of 20-25Nm. **(STEP 4)**.
- vi) Place the above assembly into the excavation and align at the correct angle and height and shim in place as required. Assemble the top bearing housing to the flange on the Spinner Support Beam using 6 off M10 x 30 Resistorx bolts (item 10) M10 Washers (item 13) and M10 Shockproof Washer (item 14). Tighten the fixing bolts to a maximum torque setting of 20-25Nm. **(STEP 4)**.

**NOTE: It is ESSENTIAL that the Spinner Ground Mounting Assembly and the Spinner are in the correct alignment when attached to the Spinner Support Beam, so that when rotated the bearings are running concentric. Any misalignment or eccentric running of this unit will cause damage to the bearings. (see STEP 5)**

- vii) Ensure that all parts are firmly held in place so that no disturbance will occur during pouring of the concrete.
- viii) Check that the completed structure has been positioned in the correct place, that it is plumb and square, that all fasteners are fully tightened to the correct torque settings. **(STEP 5)**.
- ix) Shim and brace Assembly into position.

Concrete mix is recommended at:  
 1 part cement;  
 2 parts sand;  
 4 parts aggregate;  
 by volume with 20mm aggregate  
 (20 N/mm<sup>2</sup> min compressive strength)

- x) Fill the hole with concrete to the required level, taking into account any Impact Absorbing Surfacing requirements. Ensure that the full volume of concrete is used. The top of the concrete should gradually (1:100) slope down & outwards locally from the equipment postulant to the required level to form a watershed. **(STEP 6)**
- xi) Keep installation off limits to the public until the concrete has completely cured. (Recommended initial curing time is 48 hours).
- xii) Attach the Climbing Wall Panel (item 3) to the Climbing Wall Frame (item 2) using 21 off M10 x 40 Resistorx bolts (item 9) and Shockproof washers (item 14) following the curve of the frame. **(STEP 7)**
- xiii) In all fixing positions on the steel work that have not been utilised, the protective plug should be removed and the permanent black protective plug (item 15) inserted and knocked home with a soft hammer. This also includes holes in top of Tee post smaller tubes. **(STEP 8)**

## 2 POST INSTALLATION INSPECTION

CHECK	CHECK	✓
1 The unit is installed at the correct height.	<input type="checkbox"/>	<input type="checkbox"/>
2 All fixings are tightened to the correct torque and have no protruding sharp edges.	<input type="checkbox"/>	<input type="checkbox"/>
3 Paint work and polyethylene panels are not damaged.	<input type="checkbox"/>	<input type="checkbox"/>
4 Concrete foundations are secure.	<input type="checkbox"/>	<input type="checkbox"/>
5 Concrete has had water shed away from legs.	<input type="checkbox"/>	<input type="checkbox"/>
6 Adequate provision of Impact Absorbing Surfacing with no obstructions or other hazards within the equipments minimum space.	<input type="checkbox"/>	<input type="checkbox"/>
7 Site is clear of all tools and rubbish.	<input type="checkbox"/>	<input type="checkbox"/>
8 Remove any warning signs.	<input type="checkbox"/>	<input type="checkbox"/>