

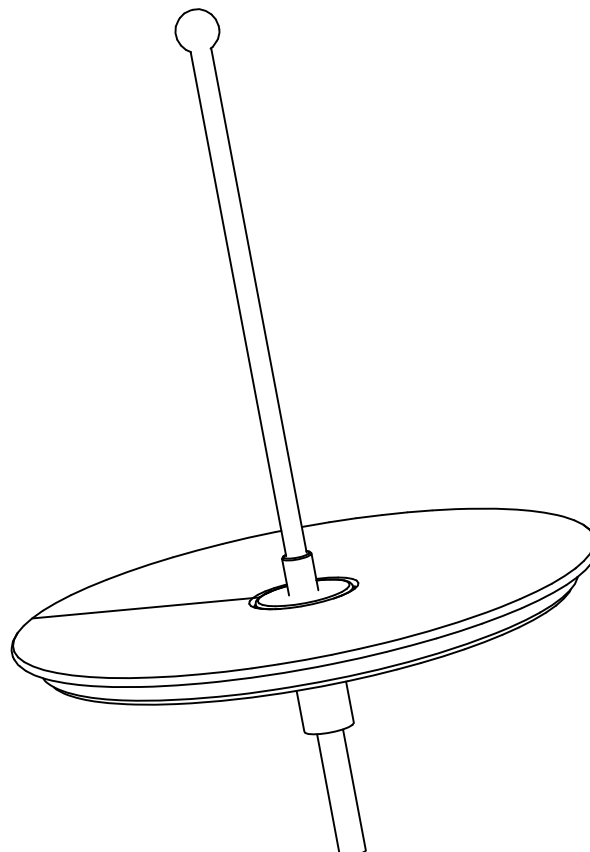





INSTALLATION INSTRUCTIONS
NEXUS MOMENTUM
NXMOM

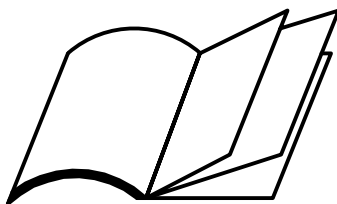

NO PART OF THIS MANUAL OR DOCUMENT MAY BE COPIED OR RE-PRODUCED IN ANY FORM OR BY ANY MEANS WITH OUT THE EXPRESS WRITTEN PERMISSION OF SMP (PLAYGROUNDS) LTD.

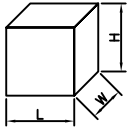
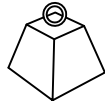
email: sales@smp.co.uk
www.smp.co.uk

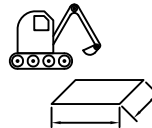
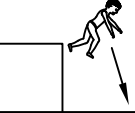

	 LxWxH (m)	 kg	 m ³	 m	 ≥EN1176	 x 3 = T
NXMOM	Ø1.20x1.76	123.0	0.80	3 x 3	0.59	T=5h

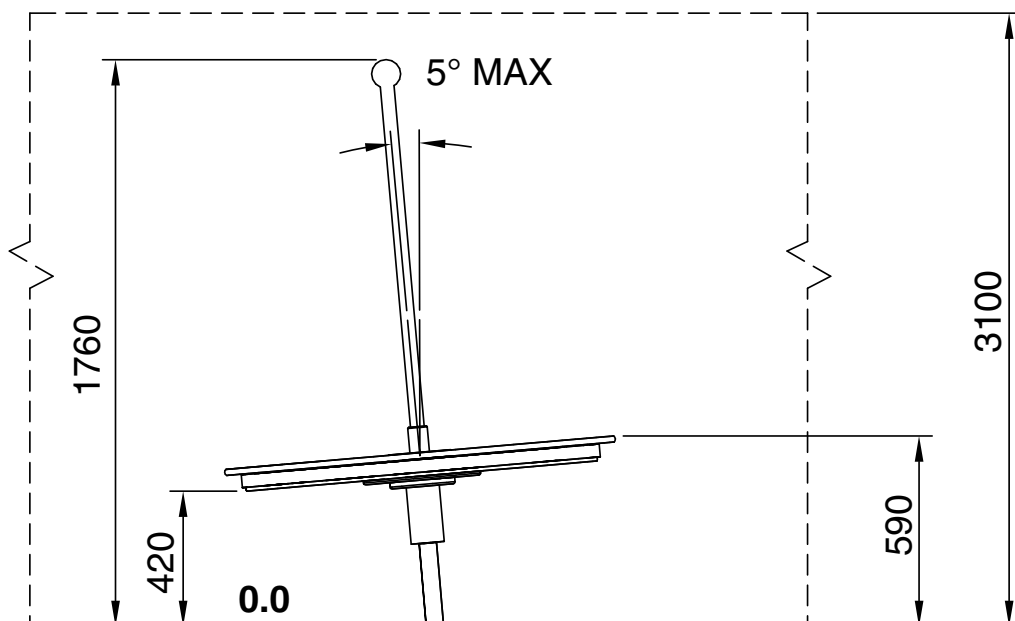
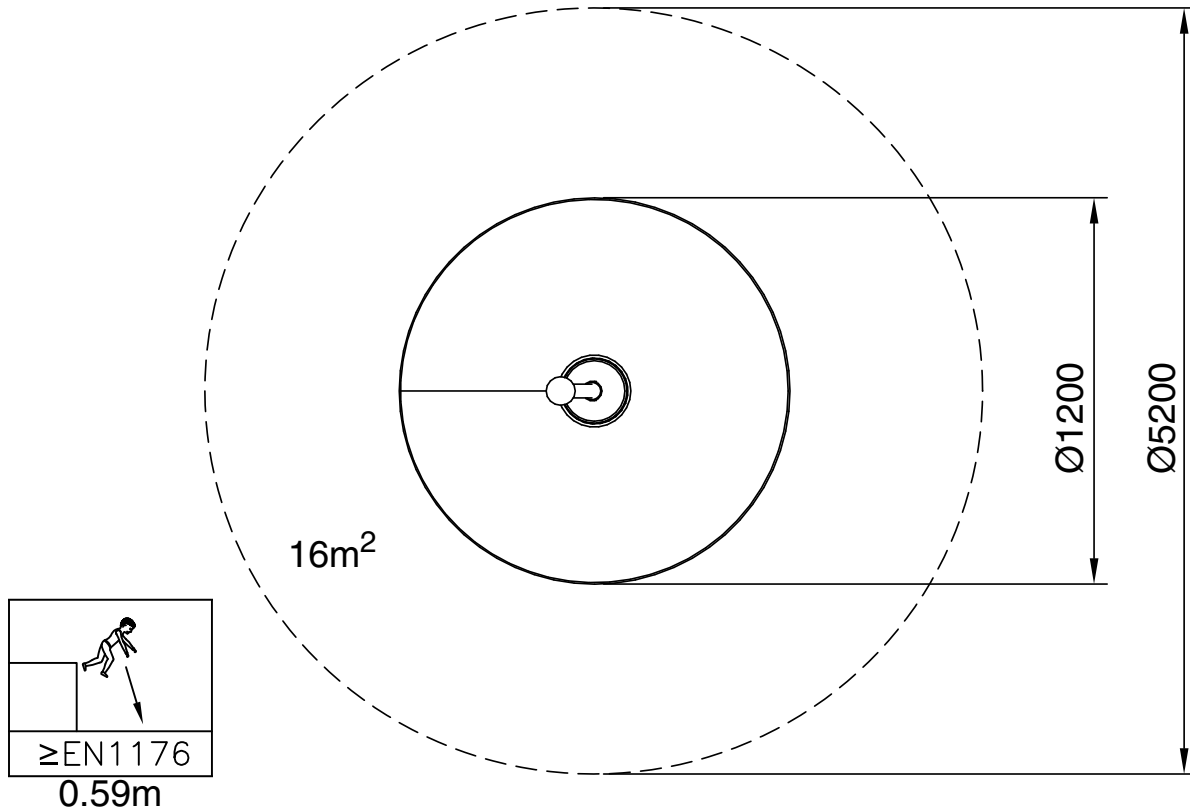

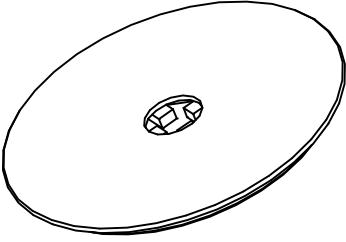
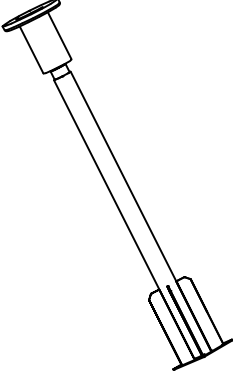
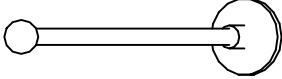
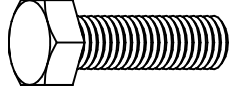
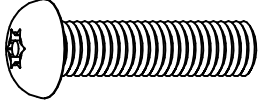
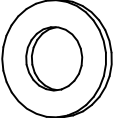
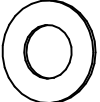
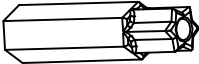
ITEM	CODE	DESCRIPTION	NXMOM QTY	WEIGHT (kg)
1	37009001		1	74.00
2	37009201		1	39.12
3	37009101		1	9.50
4	10251240	 M12 X 40	4	0.050
5	10121040	 M10 X 40	4	0.037
6	10291200	 M12 13X24X2.5	4	0.003
7	10291000	 M10 11X21X1	4	0.002
8	10121000	 T45 M10	2	-

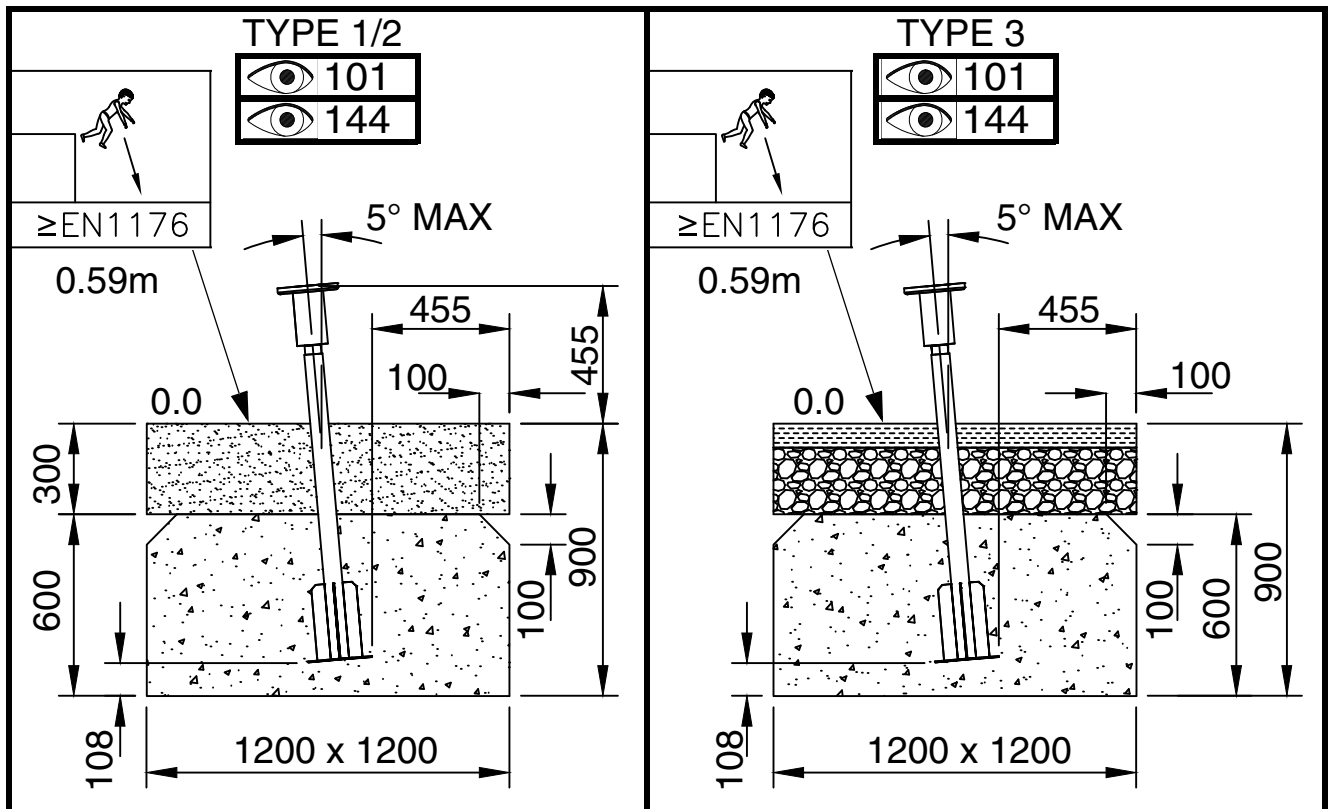

STEP 1

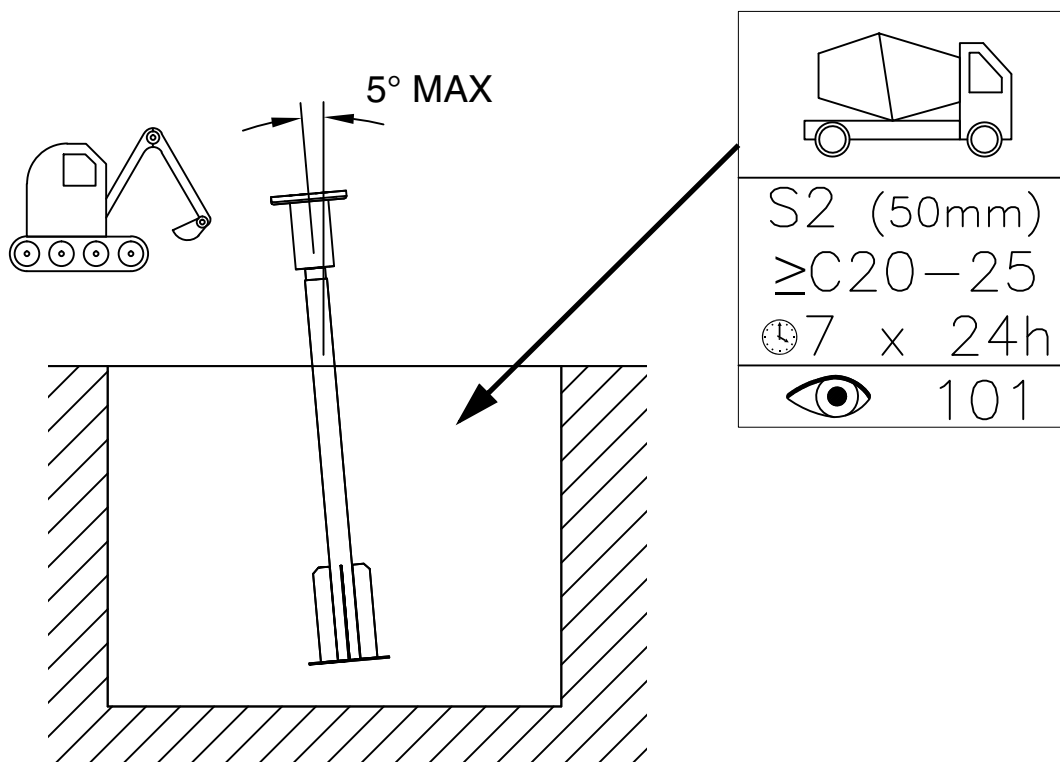

STEP 2

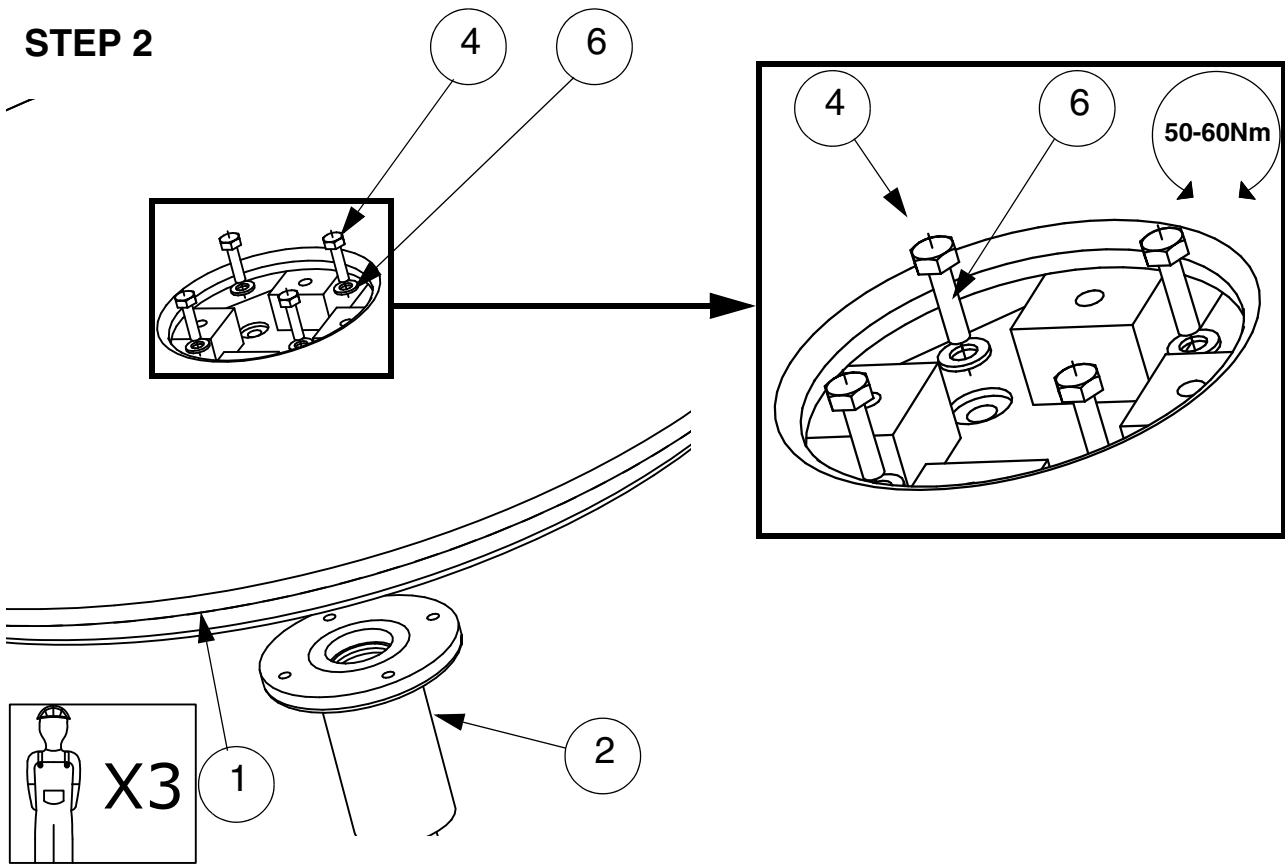

STEP 3

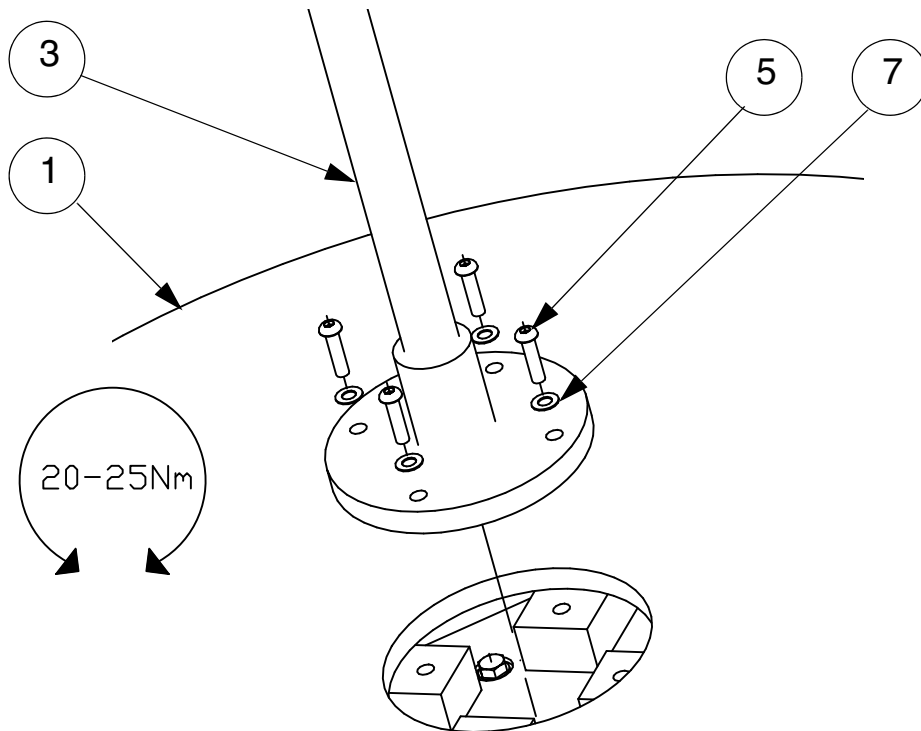

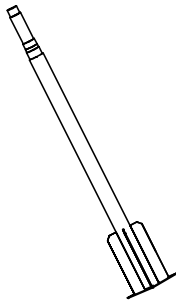
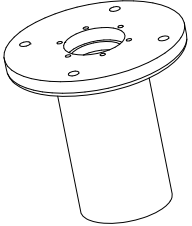
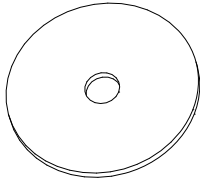
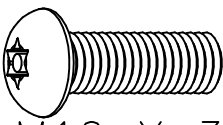
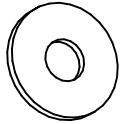

Appendix A:
REF 37009201

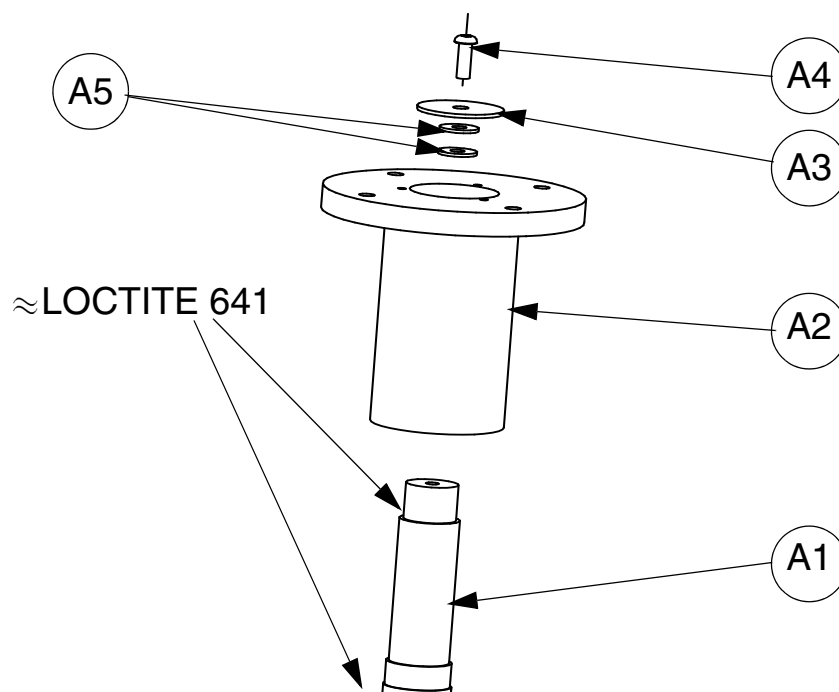
ITEM	REF		QTY.	kg
A1	37009202		1	28.00
A2	38004001		1	11.000
A3	71000109		1	0.080
A4	10121030	 M10 X 30	1	0.030
A5	10309999	 M10 11X30X2.5	2	0.011

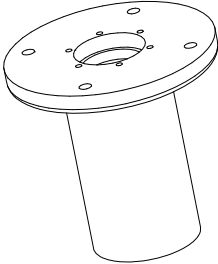

REF 38004001

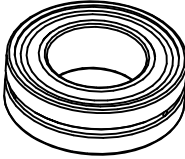
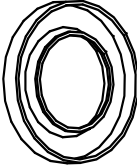
ITEM	REF		QTY.	kg
A2.1	38004012		1	10.100
A2.2	71022208		1	0.50
A2.3	71022210		1	0.70
A2.4	71000110		1	0.015

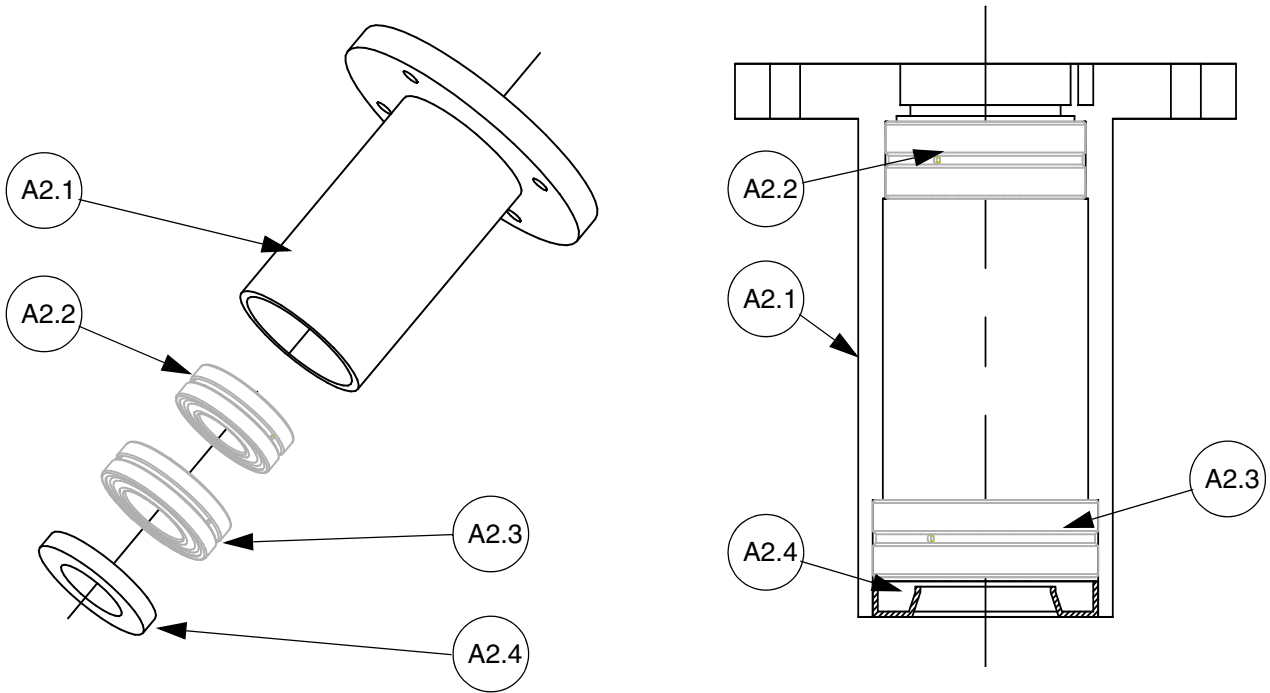

Appendix B:

REF 37009001

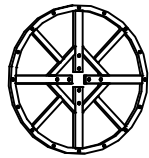
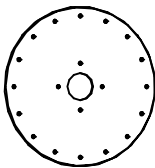
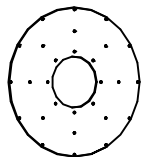
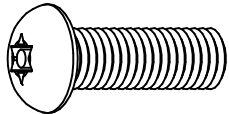
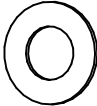
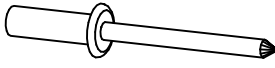
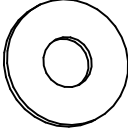
ITEM	REF		QTY.	kg
B1	37009002		1	43.00
B2	37009003		1	19.00
B3	37009004		1	11.50
B4	10121030	 M10 X 30	20	0.028
B5	10291000	 M10 11X21X1	20	0.002
B6	10350516	 5 X 16	28	0.002
B7	10290500	 M5	28	0.001

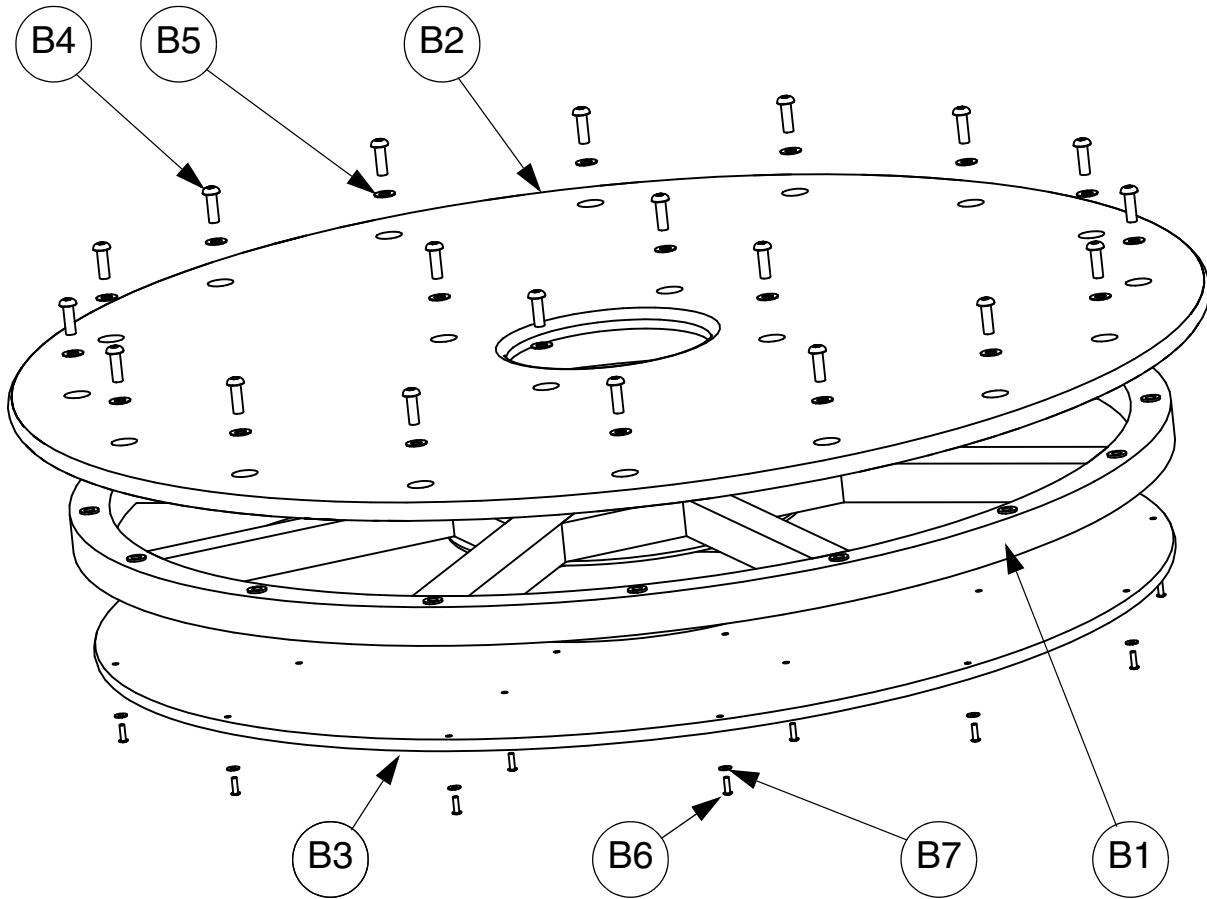

Appendix C:

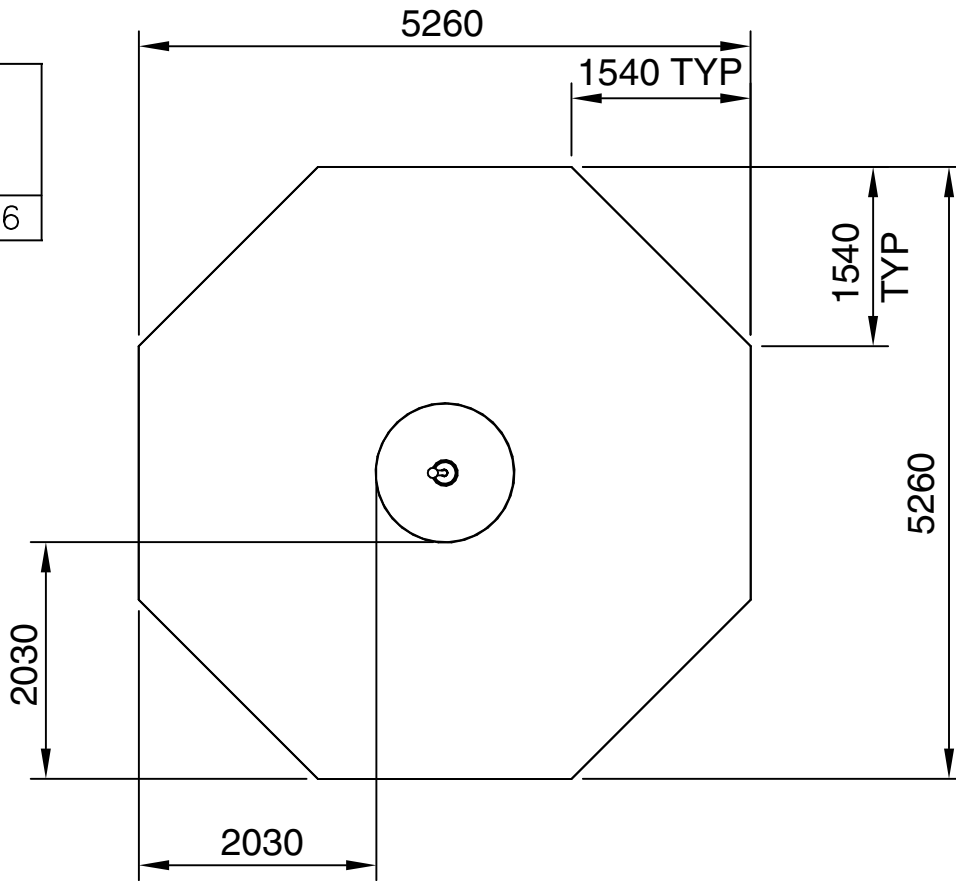
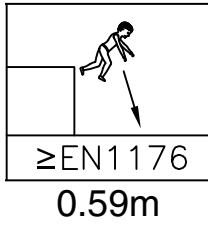

LOOSE FILL

TYPE 1/2 144

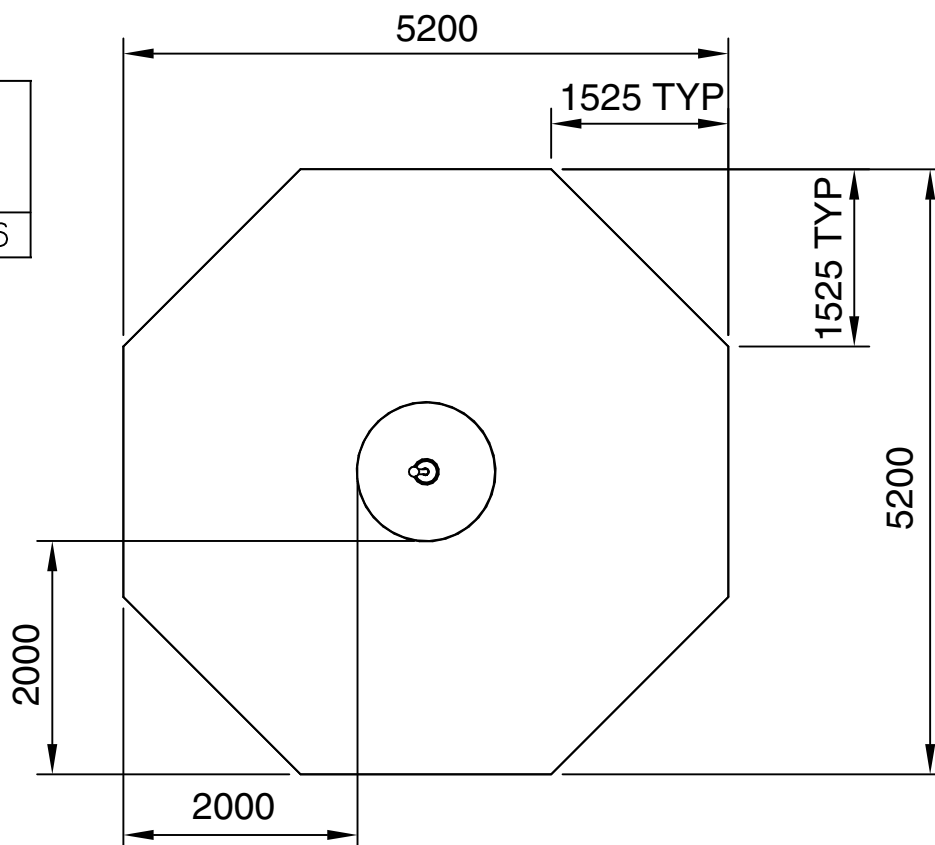
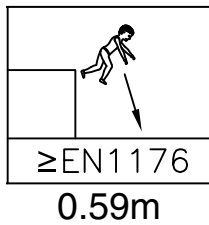

WET POUR

TYPE 3 144

SMP Playgrounds Ltd. recommends an effective *Impact Absorbing Surface tested to EN1177 & BS7188* beneath this play equipment. Refer to manufacturers instructions for details of installation. The surface should have a Critical Fall Height greater than the Maximum Freefall Height of the equipment. Subject to a risk assessment & for certain Fall Heights a grass surface may be used.

Constructional Space is the approximate working area required to lay out and assemble the equipment.

Care should be taken when siting this equipment in order to discourage users in the surrounding area from unintentionally coming into contact with the equipment. This can be achieved, for example by placing the equipment at the perimeter of the play area.

For the safe operation of this equipment it must be installed on horizontal ground with the required minimum space.

If a loose fill surface is selected for this item it will require a very high level of maintenance to ensure a sufficient thickness is in place at all times to provide 'critical fall height' protection.

The concrete foundations indicated are for average ground. Care should be taken concerning abnormal conditions.

Tools: Plumblines, 5m tape measure, Spirit level, Torque wrench, M10 Torx tool (Supplied with unit), 19mm A/F Socket, Extension bar, Protractor combination set.

1 INSTALLATION & ASSY PROCEDURES

1.1 SAFE WORKING PRACTICE:

A full risk assessment should be carried out prior to commencing the installation, which will be specific to the site selected. The major risks associated with purely the assembly of this product are highlighted below, which can form part of this overall assessment.

1.2 RISKS:

- i) Large parts which could be difficult to lift or handle.
- ii) Structure unstable until concrete footings have fully cured.

1.3 CONTROL MEASURES:

- i) All staff working on installation to wear suitable Toe Protective Shoes and Gloves.
- ii) Any staff or other persons on site, not working directly on the installation, to be kept away from the installation.
- iii) Care should be taken when any awkward/heavy lifting may be required.

Pre Installation Inspection:-

- i) Inspect all parts for damage (that may have occurred during transportation & storage). Finish Coatings, if found to be damaged these should be made good before erection (Refer to maintenance instructions). Any damaged or missing parts must be replaced.
- ii) Warn the public of the risk of injury, by placing signs and fencing the surrounding area, before commencing installation.

1.4 INSTALLATION

- i) Refer to site layout for position and orientation of product, then, mark the outline of the position of the footings with e.g. spray or chalk etc. Excavate the hole.
- ii) Position Shaft & Bearing Assembly (item 2) into excavation, pack up to height, level and plumb. **(STEP 1)**
- iii) Shim and brace Shaft & Bearing Assembly into position.

NOTE: Check that the Shaft and Bearing Assembly has been positioned in the correct place and that it is plumb, square and inclined at the correct angle with the angle pointing in the right direction. Also ensure that the assembly is propped safely so that it may be left for the concrete foundations to cure.

Concrete mix is recommended at:
1 part cement;
2 parts sand;
4 parts aggregate;
by volume with 20mm aggregate
(20 N/mm² min. compressive strength)

- iv) Fill the hole with concrete to the required level, taking into account any Impact Absorbing Surfacing requirements. Ensure that the full volume of concrete is used. The top of the concrete should gradually (1:100) slope down & outwards locally from the equipment upstand to the required level to form a watershed. **PAGE 5**
- v) Keep installation off limits to the public until the concrete has completely cured. (Recommended initial curing time is 48 hours).
- vi) Place the Deck Assembly (item 1) onto the Shaft & Bearing Assembly (item 2). Secure the deck to the bearing housing flange using 4-off M12 x 40 Hex Head Bolts (item 4) and M12 Washers (item 6). Fully tighten to 50-60 Nm. **(STEP 2)**

NOTE: This item is heavy and should be lifted by a minimum of three people.

- vii) Place Pole Fabrication (item 3) into the hole in centre of the Deck Assembly (item 1) and secure in place using 4 off M10 x 40 Resistorx bolts (item 5) and M10 washers (item 7). Fully tighten bolts to a maximum torque setting of 20-25Nm. **(STEP 3)**

2 POST INSTALLATION INSPECTION

CHECK	CHECK	✓
1 The unit is installed at the correct height. - See Page 3	<input type="checkbox"/>	
2 All fixings are tightened to the correct torque and have no protruding sharp edges.	<input type="checkbox"/>	
3 Paint work is not damaged. (Any making good should be carried out using the procedure in the Inspection and Maintenance instructions).	<input type="checkbox"/>	
4 The Eko Grip Platform is not damaged.	<input type="checkbox"/>	
5 The Momentum rotates freely.	<input type="checkbox"/>	
6 Concrete foundations are secure.	<input type="checkbox"/>	
7 Adequate provision of Impact Absorbing Surfacing with no obstructions or other hazards within the equipments minimum space.	<input type="checkbox"/>	
8 Site is clear of all tools and rubbish.	<input type="checkbox"/>	
9 Remove any warning signs.	<input type="checkbox"/>	