

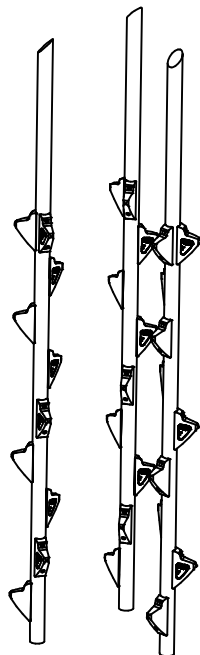

INSTALLATION INSTRUCTIONS
NEXUS DNA ANCILLARIES

NDAPA* x 3



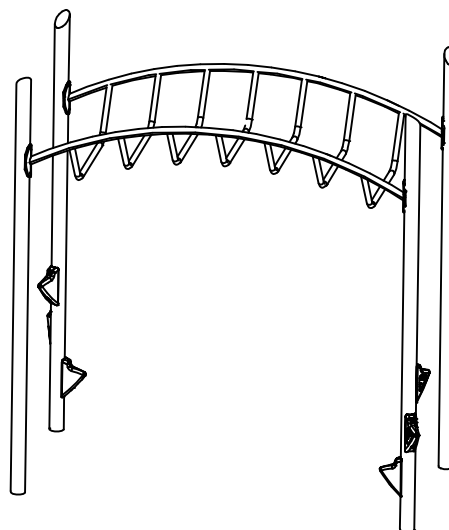

NDAPB

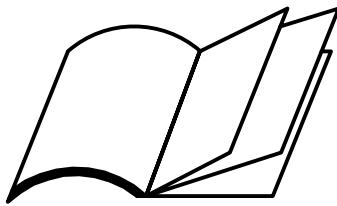



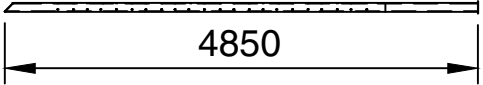
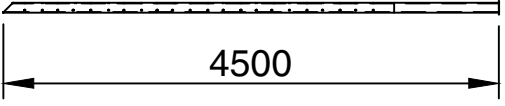
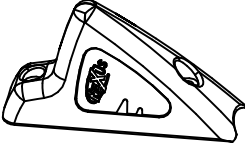

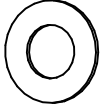
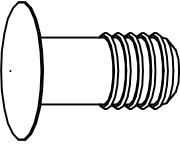
1 NDAPA*

ITEM	REF		NDAPA0	NDAPA1	kg
1	91010010		1		56.00
	91010020			1	52.00
2	38009089		9	8	0.75
3	10121065	 M10 X 65	18	16	0.037
4	10291000	 M10 11X21X1	18	16	0.002
5	19024501		48	50	0.001

NDAPA0

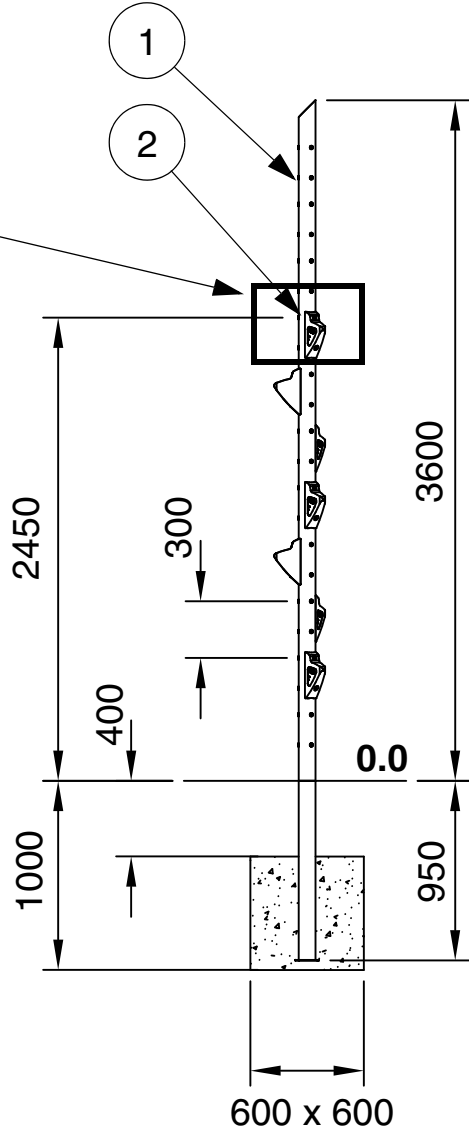
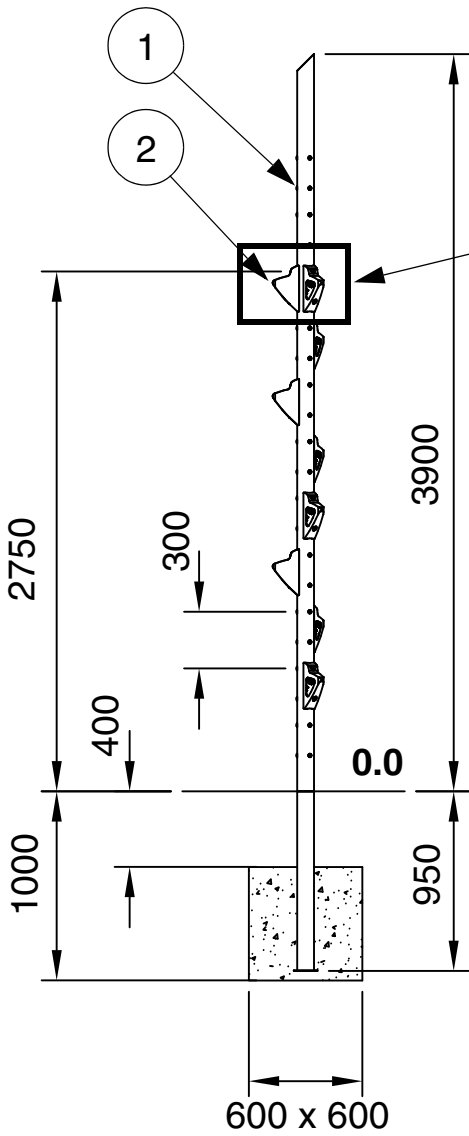

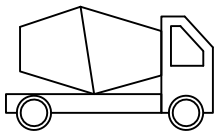

NDAPA1

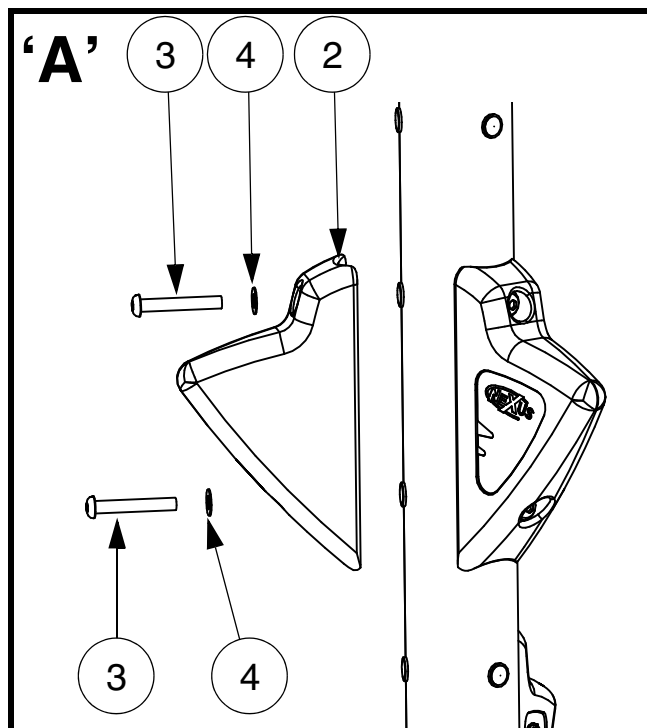

	
S2 (50mm)	
≥C20-25	
	7 x 24h
	101

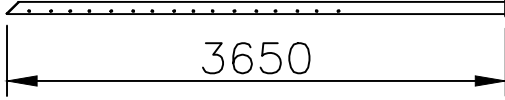
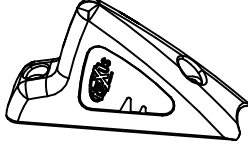

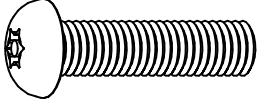
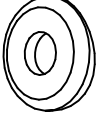
2 NDAPB0

ITEM	REF		QTY	kg
1	91030020		1	56.00
2	91061310		4	43.00
3	38009089		6	0.750
4	19023802		4	0.050
5	10121065	 M10 X 65	12	0.037
6	10121040	 M10 X 40	8	0.037
7	38001019	 M10 12X32X6.5	8	0.002
8	10301000	 M10 12X18X1	20	0.001

CODE	'A'
NDAPB0	2231.9mm

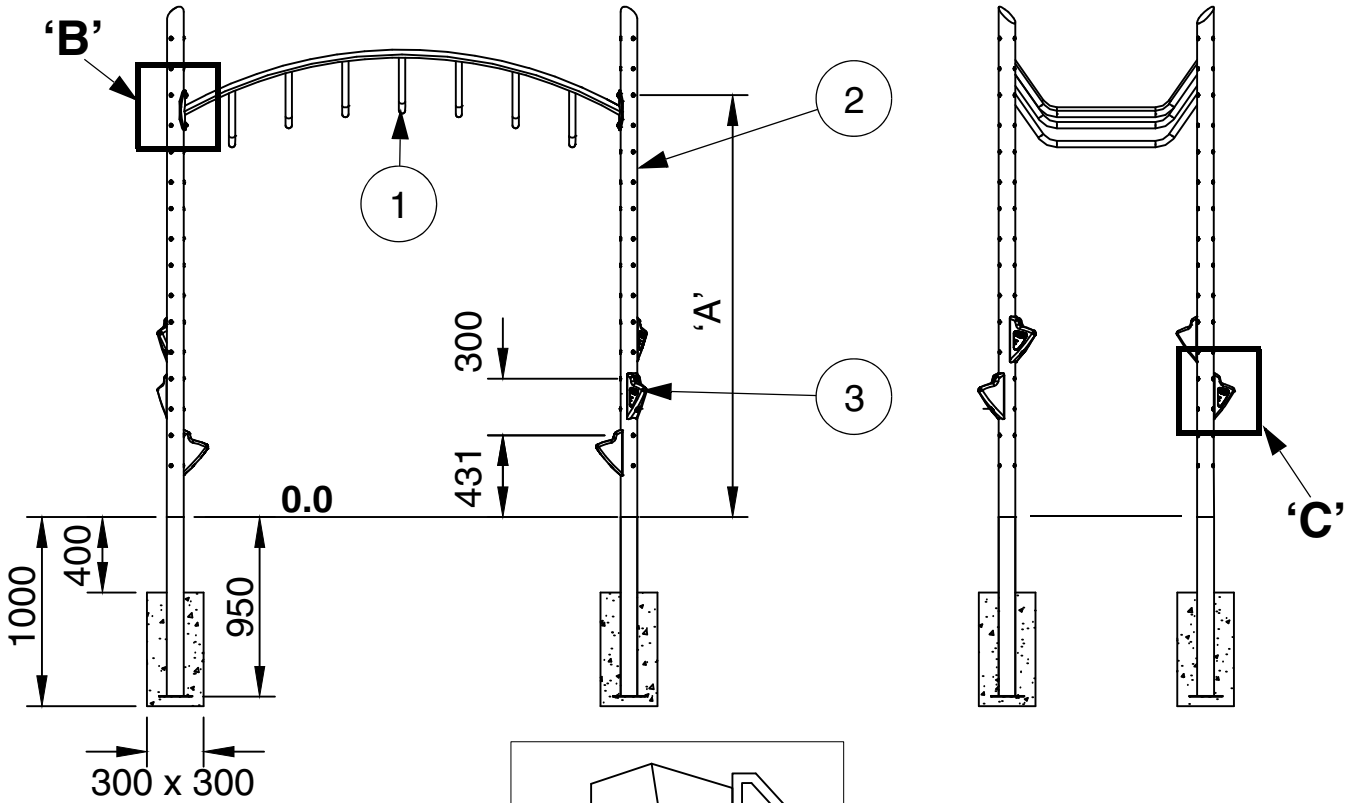

S2 (50mm)	
≥C20-25	
🕒	7 x 24h
👁️	101

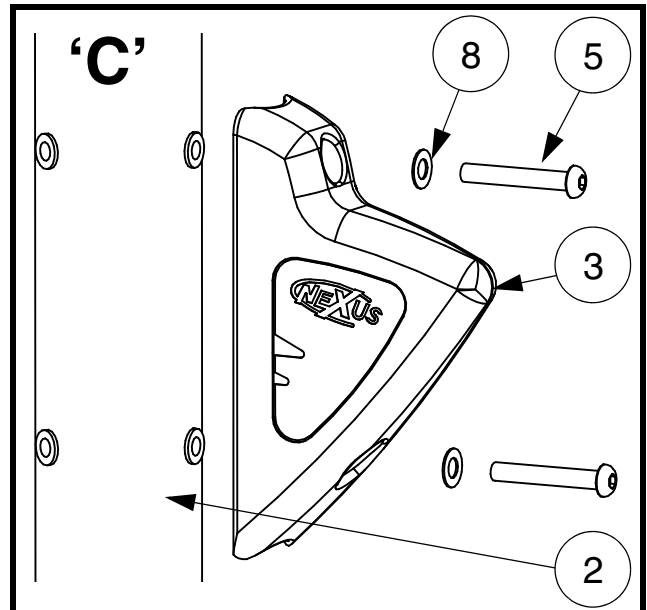
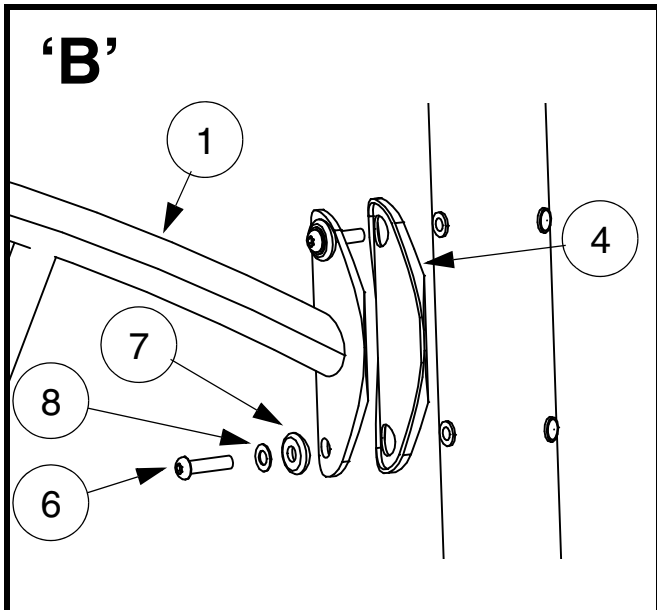

Appendix A:

1 SAFE WORKING PRACTISE

A full risk assessment should be carried out prior to commencing the installation, which will be specific to the site selected. The major risks associated with purely the assembly of this product are highlighted below, which can form part of this overall assessment.

1.1 RISKS:

- i) Large parts which could be difficult to lift or handle.
- ii) Structure unstable until concrete footings have fully cured.
- iii) Parts at height that may require working overhead.

1.2 CONTROL MEASURES:

- i) Warn the public of the risk of injury, by placing signs and fencing the surrounding area, before commencing installation.
- ii) All staff working on installation to wear suitable PPE including Toe Protective Shoes, Hard hat and Gloves.
- iii) Any staff or other persons on site, not working directly on the installation, to be kept away from the installation.
- iv) Ensure adequate personal and equipment are on site to handle and support the structure whilst it is being assembled.

2 SPECIFICATIONS

SMP Playgrounds Ltd recommends an effective *Impact Absorbing Surface tested to EN1177 & BS7188* beneath this play equipment. Refer to manufacturers instructions for details of installation. The surface should have a Critical Fall Height greater than the Maximum Freefall Height of the equipment.

Constructional Space is the approximate working area required to lay out and assemble the equipment.

For the safe operation of this equipment it must be installed on horizontal ground with the required minimum space.

The concrete foundations indicated are for average ground. Care should be taken concerning abnormal conditions.

If a loose fill surface is selected for this item it will require a very high level of maintenance to ensure a sufficient thickness is in place at all times to provide 'critical fall height' protection.

Care should be taken when siting this equipment in order to discourage users in the surrounding area from unintentionally coming into contact with the equipment. This can be achieved, for example by placing the equipment at the perimeter of the play area.

3 PREPARATION

All equipment assembly and fixing must conform to EN1176.

Tools / ancillary equipment: 10m tape measure, Spirit level, M10 Torx tool (Supplied with unit), Torque wrench, Plumbline, 19mm A/F Socket, Extension bar. Loose fill: Masking tape, Paint brush, Black paint,

3.1 ESTABLISH ORIENTATION

- i) See Specifications for equipments 'Minimum space'.
- ii) Measure out the site to ensure the space required fits into the allotted area, it is horizontal and free from trip points or other obstructions.
- iii) Ensure the equipment is to be provided with an effective Impact Absorbing Surface which has a tested critical fall height rating greater than the maximum freefall height of the equipment.

3.2 MARK OUT HOLES

Consult SMP layout drawing for structure position on site.

See **pages 4 & 5** for concrete foundation size.

NOTE: This is a minimum guide only.

3.3 ESTABLISH DATUM LEVEL

- i) If a rubber tiled Impact Absorbing surface is to be laid, see separate instructions (base may incorporate up to 2% falls etc).
- ii) If equipment is to sit in loose fill or wet pour rubber surfaces allowances will need to be made for its recommended thickness. Generally it is recommended that loose fill surfaces are installed to a minimum depth of 400mm, however, with certain loose fill materials a greater depth may be required. This will need to be determined by allowing 100mm for the dispersal in addition to the thickness required for the particular Free Fall Height. The foundation illustrated will allow for a thickness up to 400mm.

PRE-INSTALLATION INSPECTION

Inspect all parts for damage (that may have occurred during transportation & storage). Finish Coatings, if found to be damaged these should be made good before erection (Refer to maintenance instructions). Any damaged or missing parts must be replaced.

4 CHECKS

Check that the completed structure has been position in the correct place, that it is plumb and square and then fully tighten all fasteners. Do not exceed 20-25Nm torque or the inserts will dislodge and turn. Also ensure that the structure is propped safely so that it may be left for the concrete foundations to cure.

In all fixing positions on the steel work that have not been utilised: the temporary protective plug should be removed and the permanent black protective plug, Pt.No.19024501, inserted & knocked home with a soft hammer.

5 CONCRETE IN

- i) Concrete mix is recommended at:
 - 1 part cement;
 - 2 parts sand;
 - 4 parts aggregate;
 - by volume with 20mm aggregate
 - (20N/mm² min compressive strength)
- ii) Fill the holes with concrete to the required level, taking into account any Impact Absorbing Surfacing requirements. Ensure that a full volume of concrete is used. The top of the concrete should gradually (1:100) slope down & outwards locally from the equipment upstand to the required level to form a watershed.
- iii) Keep installation off limits to the public until the concrete has completely cured. (Recommended initial curing time is 48 hours). When concrete has fully cured attach all polyethylene components and grips.)

6 POST INSTALLATION INSPECTION

CHECK	CHECK	✓
1 The unit is installed at the correct height.	<input type="checkbox"/>	<input type="checkbox"/>
2 All fixings are tightened to the correct torque and have no protruding sharp edges.	<input type="checkbox"/>	<input type="checkbox"/>
3 Paint work is not damaged.	<input type="checkbox"/>	<input type="checkbox"/>
4 The polyethylene is not damaged.	<input type="checkbox"/>	<input type="checkbox"/>
5 Concrete foundations are secure.	<input type="checkbox"/>	<input type="checkbox"/>
6 Adequate provision of Impact Absorbing Surfacing with no obstructions or other hazards within the equipments minimum space.	<input type="checkbox"/>	<input type="checkbox"/>
7 Site is clear of all tools and rubbish.	<input type="checkbox"/>	<input type="checkbox"/>
8 Remove any warning signs.	<input type="checkbox"/>	<input type="checkbox"/>

