

Produced by Tayplay (Structures) Limited

#### Special points of interest

Polished stainless steel mast  
with solid aluminium dome

18mm dia Nylon braided rope  
with steel re-enforcement

Galvanised foundation  
steelwork

Netform 'HD' aluminium  
rope connecting system

Low maintenance

#### Product Overview

The Active 4000 Activity net is designed to be used by children from 5 years of age and has been manufactured to exceed the European playground standard bs-en 1176-1(1998).

The following installation instructions should be adhered to in order that the equipment functions in a safe manner.

#### Contents

Space requirements & Free height of fall	Page 2
Installation Overview	Page 3
Requirements (1)	Page 4
Setting Out	Page 5-6
Excavation & Concreting	Page 7-9
Assembly instructions (1)	Page 10

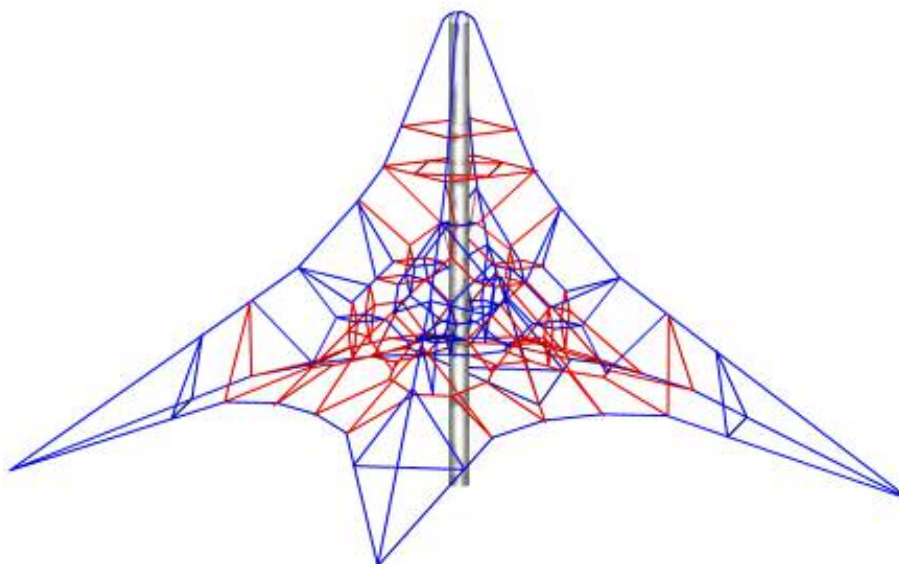

## Space Requirements & Safety Clearances

The requirements for space and safety clearances are extracted from bs-en 1176-1

4.2.8 zones

4.2.8.1.2 free space

the equipment should be situated to allow a minimum of 2.0m free space from the corner of the product at ground level. This translates into a 9.5 m square.

Total area required based on square layout = 90.25 m<sup>2</sup>

### FINISHED ASSEMBLY SHOWING RECOMMENDED SAFETY ZONE & SAFETY SURFACE AREA

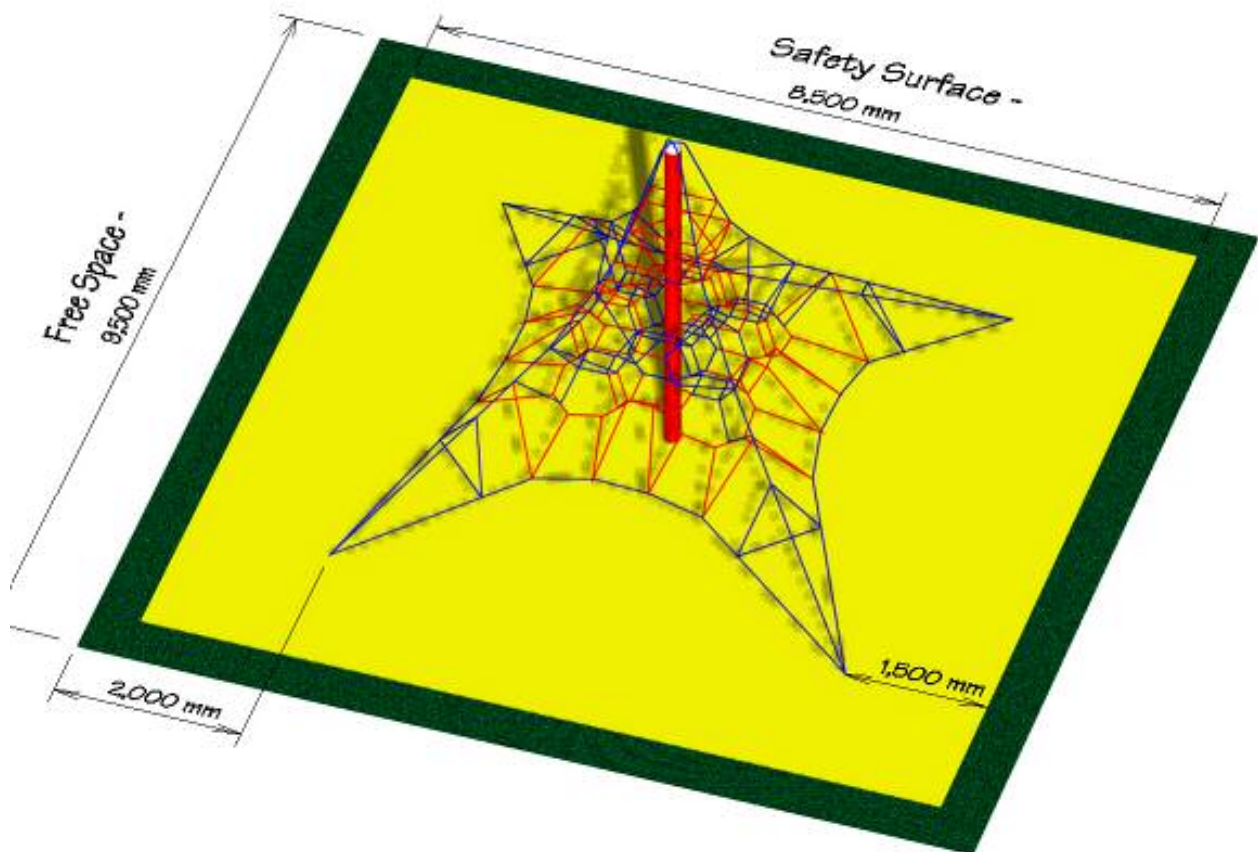

### Free Height of Fall

The maximum height from which a child can fall vertically is 850 mm, (the highest point on the perimeter rope). This is considered to be the free height of fall and therefore a rubber safety surface, **minimum 45mm thick**, is required (in the area shown in Yellow above) below the product.

## Installation Instructions

The active 4000 activity net is delivered in four sections.

Section (1) is the polished stainless steel mast, which is to be mounted over the central spigot of the foundation steelwork leaving the top of the mast to accept the aluminium dome. This is attached to the top of the net.

Section (2) is the net, complete with aluminium dome, to be inserted into the top of the mast

Section (3) is the foundation steelwork. This comprises of four galvanised ground anchors (Fig. 1), one central galvanised spigot (fig. 2). The package will also contain 4 rigging screws (see fig. 3) for attaching and tensioning the net at each corner to the foundation steelwork. (See page 4 for setting out & concreting instructions for the foundations).

Section (4) is the galvanised corner boxes in flat pack form, including all fittings

Fig. 1 – corner anchor

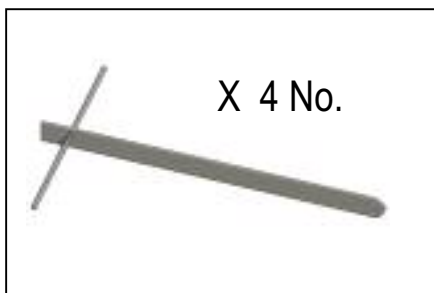

Fig. 2 – central spigot

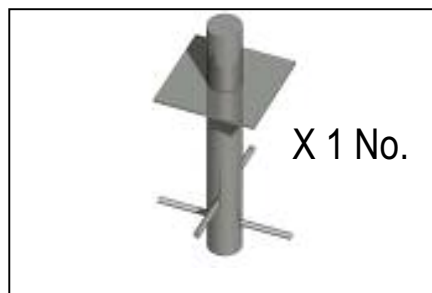

Fig. 3 – rigging screw

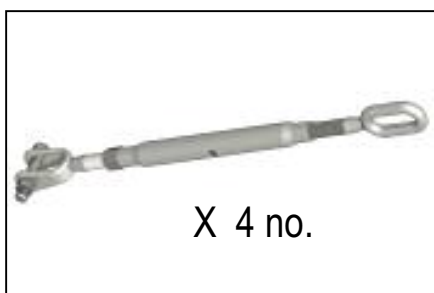
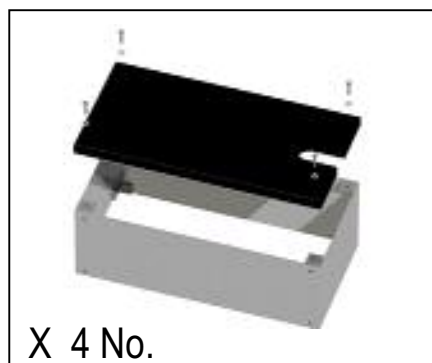

Fig. 4 – corner box



Please note:

The four rigging screws and the four corner box lids are not required until final erection of the activity net. As all items are delivered together, it is therefore recommended that the rigging screws and corner box lids are kept in a secure place, along with the net and mast, until then.

## **Foundation requirements**

### **- General:**

The Active 4000 net has been designed to allow a rubber safety surface, of a finished minimum thickness of 45 mm, to be placed below the net.

It is recommended the area is prepared accordingly prior to commencing installation of the net.

### **- Equipment & Tools:**

The following equipment is recommended to assist in the accurate installation of the foundation anchors.

- 1) laser level (or similar) to determine accurate height position of foundation steelwork prior to concreting.
- 2) 20 m steel measuring tape
- 3) JCB Excavator (or similar) with certified driver
- 4) Setting out timber – (refer to fig. 4, & fig. 5 on page 5 of the installation instructions)
- 5) Manual tools – including spade, sledge hammer, claw hammer and nails

Although site conditions can vary, the following timescales should be used as a guide by a team of two installers, utilising the above equipment, to fully complete the erection of the Active 4000 activity net.

Day one –

- 1) set out the area
- 2) accurately position and excavate holes (add shuttering if required)
- 3) securely position central stump, corner foundations and corner boxes for concreting

Day two -

- 1) concrete steelwork (half day)

Day three\*\* -

- 1) final erection of activity net
- 2) laying of loose-fill safety surface material

(\*\* Please allow a minimum of seven days between concreting and final erection of the net to allow the concrete to 'cure' and gain satisfactory strength)

### Foundation setting out plan & dimensions

Fig. 4

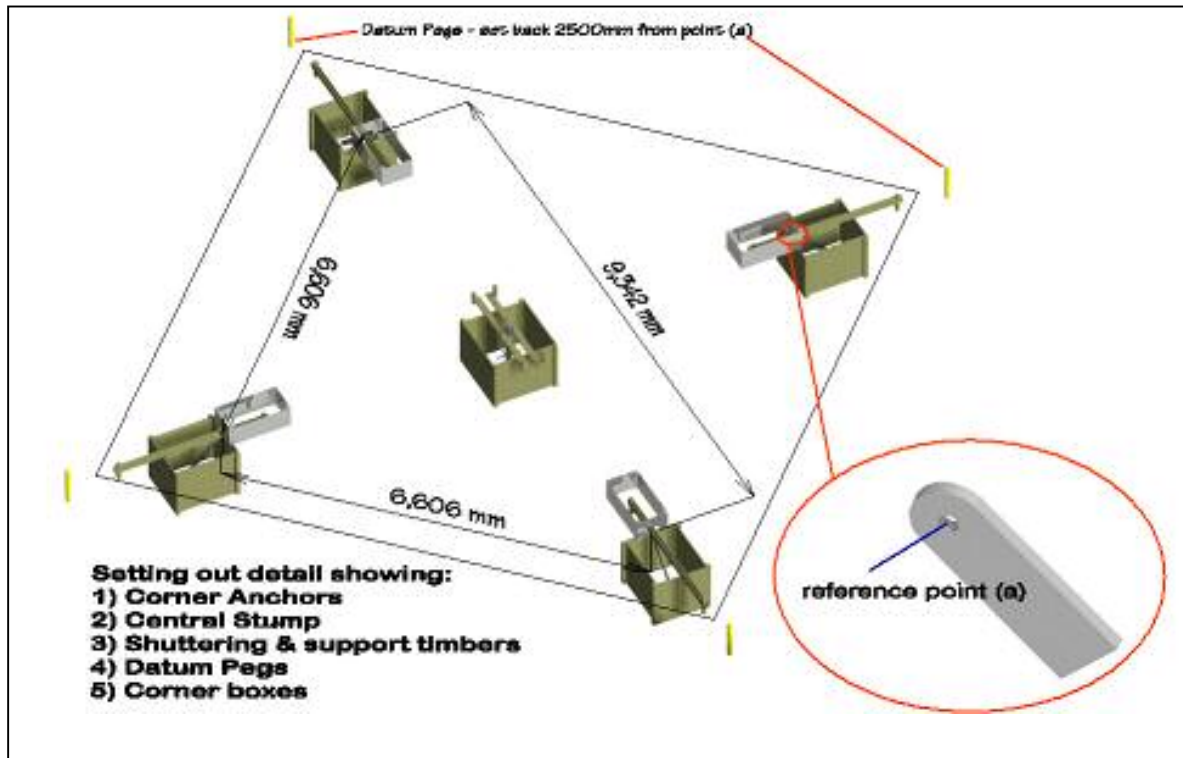
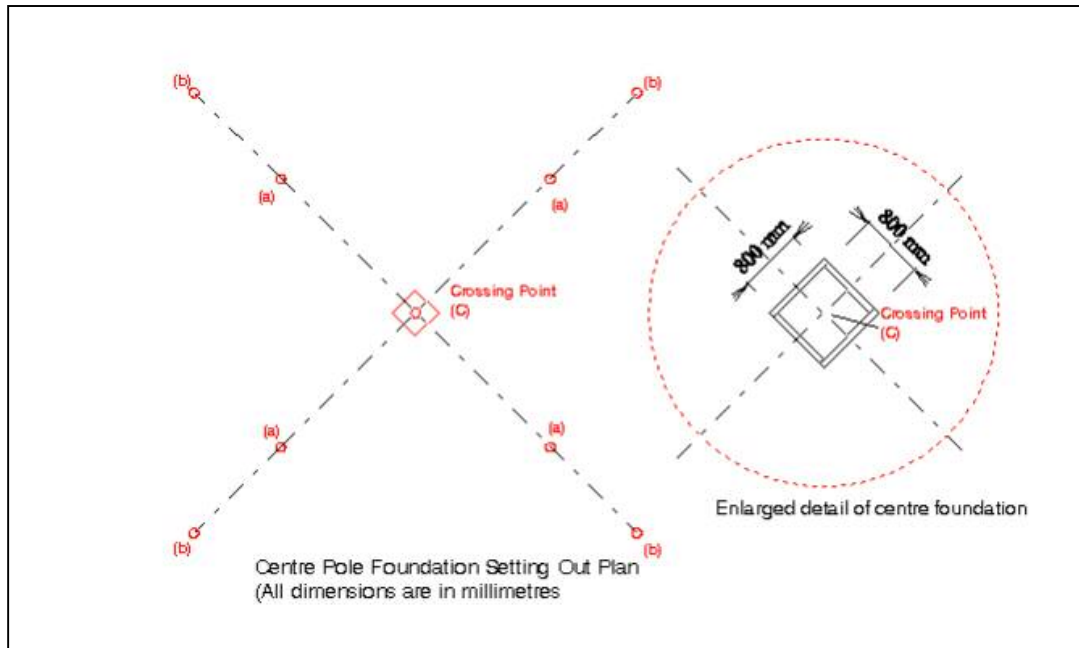

Fig. 5



### Procedure (1) – setting out

There are a total of five holes that need to be excavated. These include one centre hole (the final position of the central mast) and four holes at each corner (the net will be attached to the subsequently concreted corner anchors by means of rigging screws supplied (refer back to Fig. 3)

#### NOTE:

**Corner foundation** holes are to measure - 1000 (l) x 1000 (w) x 800 (d) mm

**Centre foundation** hole is to measure – 800 (l) x 800 (w) x 800 (d) mm

**& all foundation concrete blocks must be at the same level**

It is important to maintain 400 mm between the finished surface level of the safety surface and the top surface level of the concrete (see fig. 6 below)

Once the correct position of the holes has been marked prior to excavation, the use of a datum peg (point (b) see Fig. 5 on page 5) is recommended in order to easily relocate the exact foundation position (both horizontally and vertically) which was originally established during setting out.

Fig. 6 – setting out levels

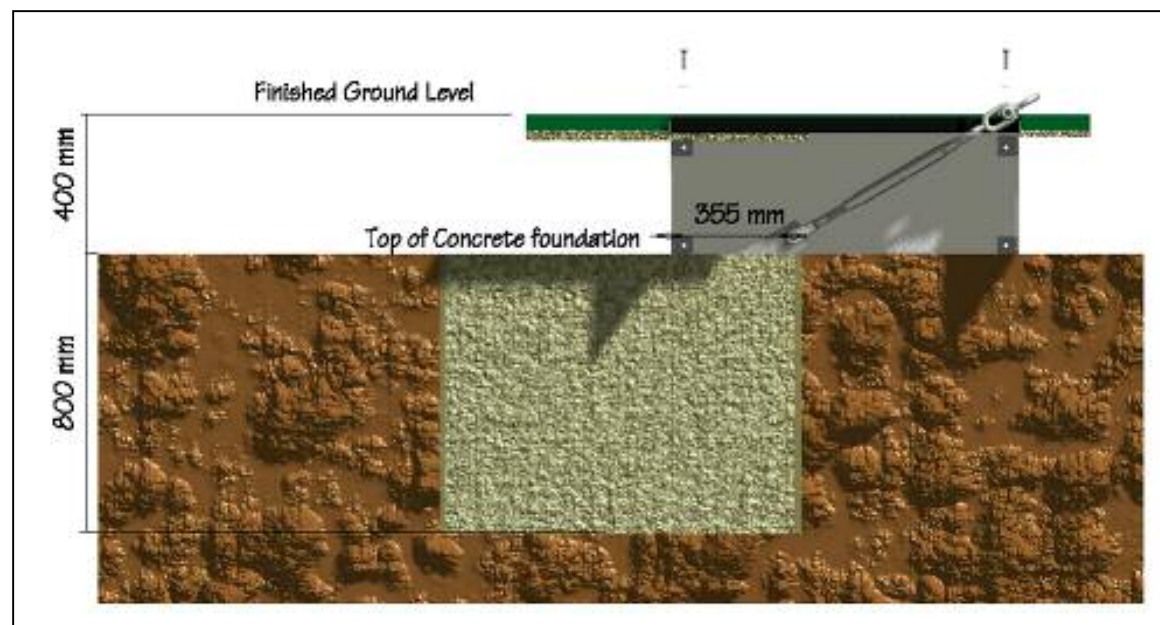

**Procedure (2) –excavation and foundation positioning** (See also Fig. 9 on page 8 for box positioning)

In loose ground, it may be necessary to use timber framework (or shuttering) to prevent soil falling into the hole. It will also prevent an unnecessary excess volume of concrete being used  
(See fig. 7 - 10 for recommended framework supports).

Concrete to be 30/n mm<sup>2</sup> mix, Total volume required= 5.408 cubic metres

Fig. 7 – Corner foundation before concreting (See also Fig.8 below)

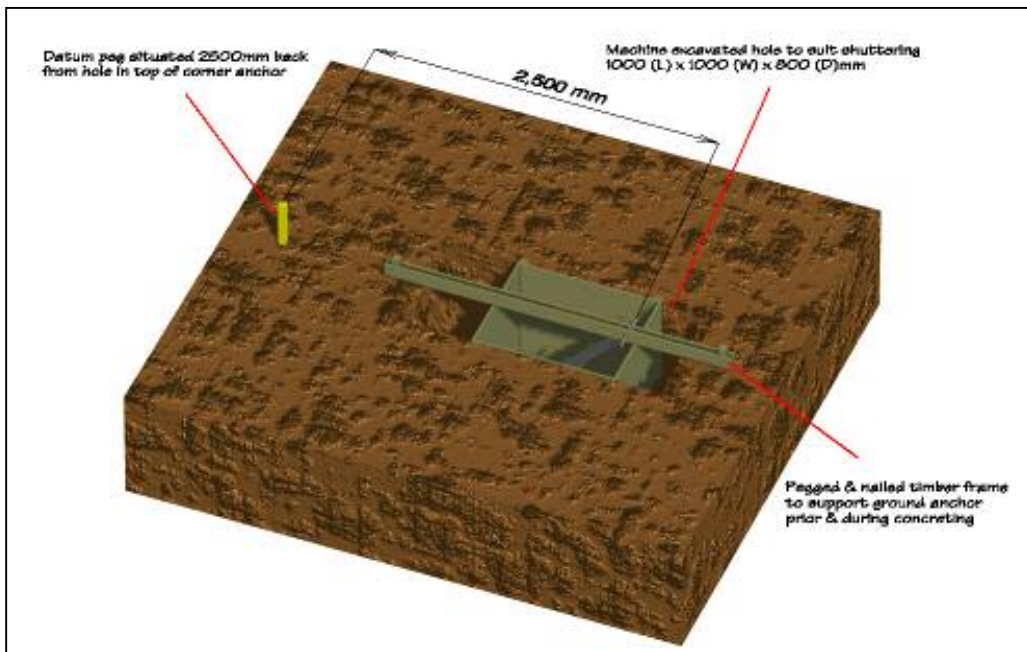

Fig. 8 – Corner foundation including box before concreting

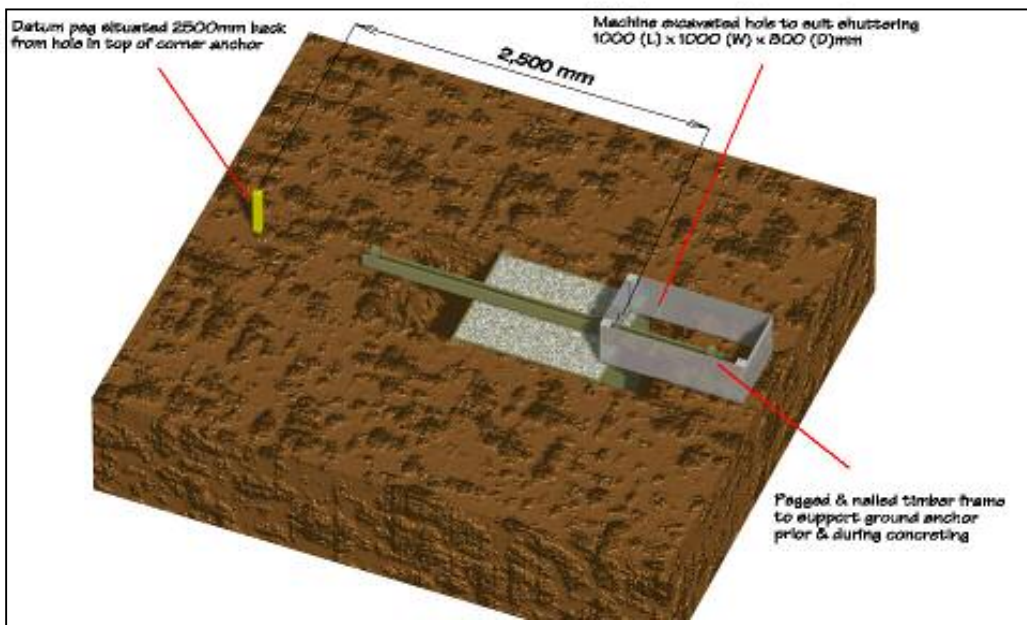
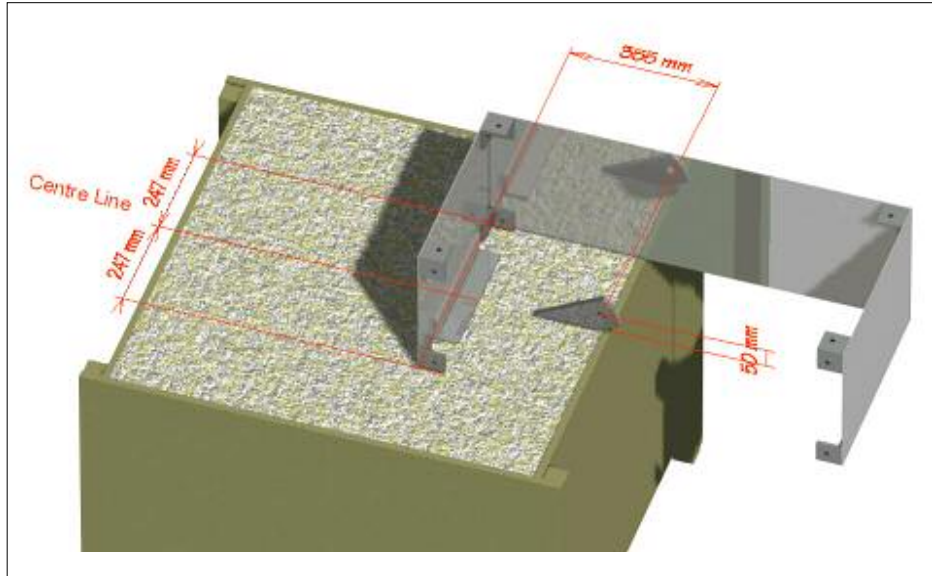

Fig. 9 – Corner foundation with box after concreting



When installing the four corner anchors, it is extremely important to ensure the eyes of the anchor are located as shown in fig 4. (shown on page 5), and are held securely during concreting to minimise any movement.

Following the concreting of the corner foundations, the corner boxes will be secure in the concrete foundation.

Backfilling of soil around the foundation, along with laying of hardcore sub-base for the rubber safety surface can now take place. Take care not to fill the corner box with any excess materials during this operation to limit any clearing out during final installation of the activity net.

Fig. 9 – centre foundation before concreting

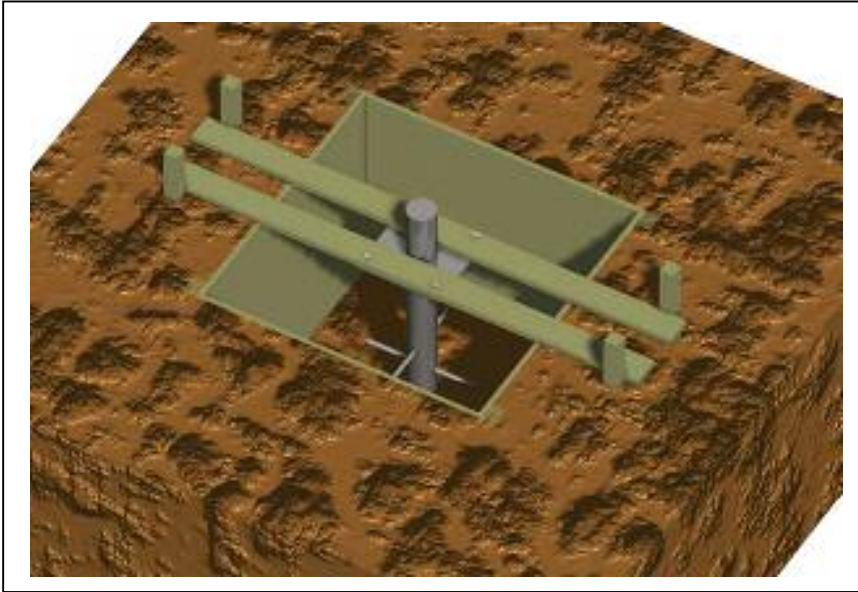
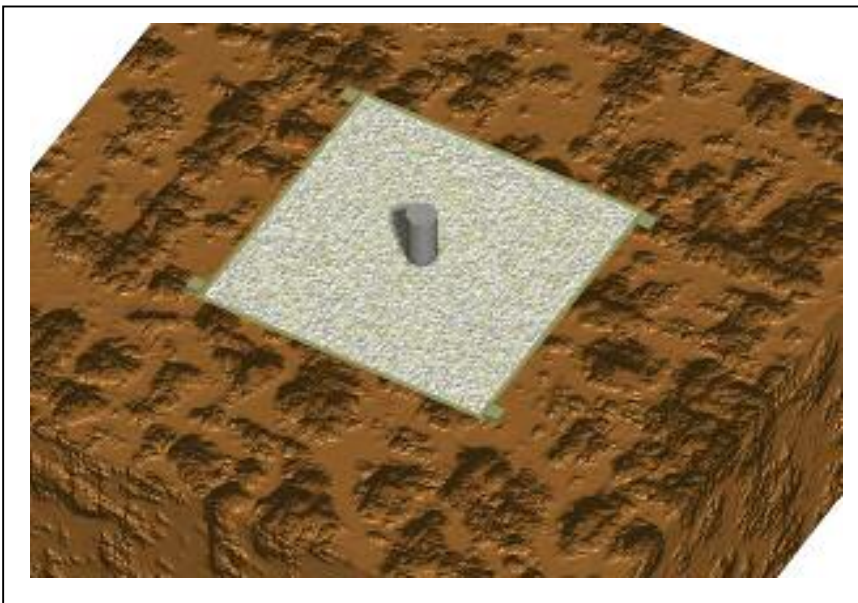

fig. 10 – centre foundation after concreting



Install the centre foundation spigot as shown in fig. 9 above. Use bolted temporary timber supports to suspend and secure the anchor during concreting.

**Note:**

To easily remove the support timbers following concreting, secure the timbers by bolting from the underside of the spigots top plate.

## Assembly Instructions (1)

Following a 7 day curing period, to allow the concrete to gain adequate strength, the final erection of the net can take place.

- 1) Remove the packaging from the net & mast supplied
- 2) Lay the net out on the ground so that all four corners are clearly visible
- 3) Thread the mast through the net (as shown in the diagrams below) and locate the aluminium cap (fixed at the top of the net) into the end of the mast

(note: the orientation of the mast can be determined from the position of the manufacturers label. This should be to the bottom of the mast).

Fig. 11 STEP ONE

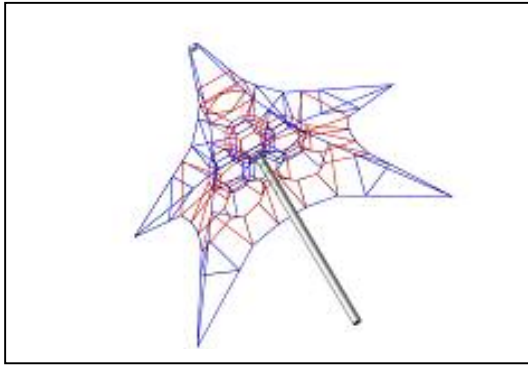

Fig. 12 STEP TWO

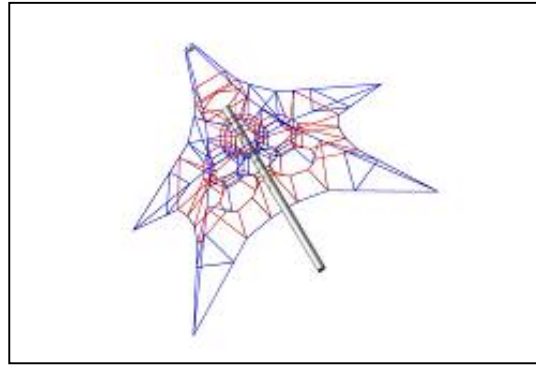

Fig. 13 STEP THREE

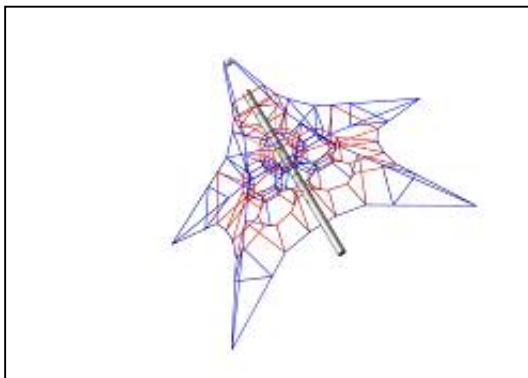
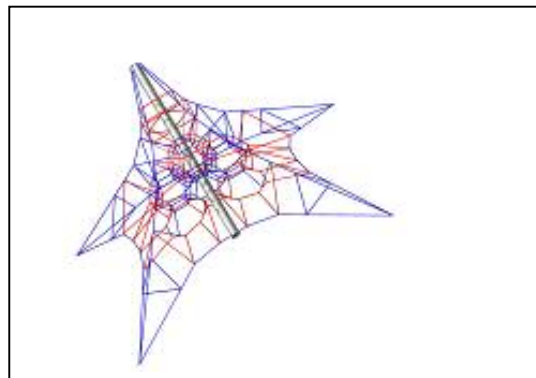
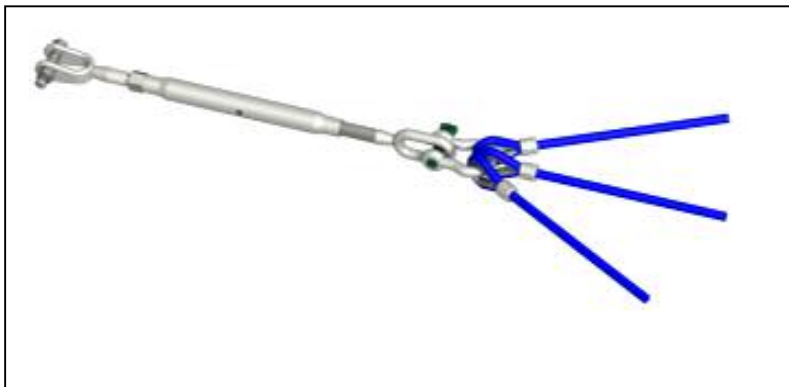

Fig. 14 STEP FOUR



## Assembly Instruction (1) - continued

After successfully preparing the net and mast assembly, attach the four rigging screws previously stored, to each of the four corners of the net using the 'green pin' bow shackles. The bow shackles can be located, already attached, at the net corners. The rigging screw should be attached so that the 'eye' end is connected to the shackle, leaving the 'jaw' end to attach to the corner anchors at point (a) as shown on previous drawings



## Assembly Instructions (2)

- 1) To lift the net and mast into their final position, connect a sling (rope or webbing) to the upper part of the mast and lift using the excavating machine. **Note: do not, under any circumstances, allow the lifting of the item using only the net as support as this can cause irreparable damage to the net. The mast must take the support.** The certified excavator operator will be able to assist in this operation.
- 2) Locate the base of the mast over the centre spigot. With the excavator still taking the weight, connect the rigging crews to the four corner anchors at point (a). the rigging screws should be extended to their maximum length at this stage.
- 3) Once all four rigging screws have been attached, the net is then self supporting and the excavator can be released. Ensure the aluminium cap is correctly orientated and tighten the rigging screws uniformly. Adjust the tension until the mast is vertical then tighten the locknuts on the rigging screws. Secure the corner boxes with their lids using the security bolts supplied.

## **Post installation tensioning & maintenance**

The active 4000 net is almost maintenance free; all that is required is a weekly check to ensure that no acts of vandalism have damaged the rope.

Periodic checks on tension will help assist in the durability of the product.

**After initial tension is complete, the net will stretch slightly (approximately 1%) over the first two to three weeks of use. Following this initial period, the net needs to be fully re-tension by releasing the locking nuts and evenly re-tightening the rigging screws as explained on page 11 (assembly instructions (2)).**

This should be all that is necessary for maintenance.

It is, however, recommended that subsequent checks on tension should be carried out at monthly intervals and adjusted as required. This will increase the overall longevity of the product

---

**Please leave a copy of the Active 4000 instructions with your customer following installation to assist them with any future maintenance requirements**

---

**For further information on the 'Netform' range of rope-play products, or technical assistance regarding the Active 4000 Activity Net, contact the original manufacturer at:**

**Tayplay Limited  
Unit 15b, Riverview Business Park  
Friarton Road  
Perth  
PH2 8DF  
United Kingdom**

**Tel: +44 (0)1738 449084  
Fax: +44 (0)1738 449094  
E-mail: [info@tayplay.com](mailto:info@tayplay.com)  
Web: [www.tayplay.com](http://www.tayplay.com)**

