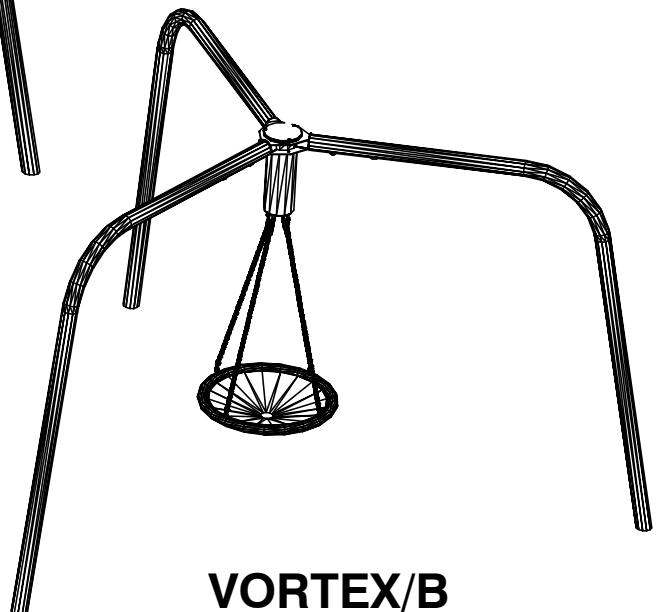




**INSTALLATION INSTRUCTIONS**  
**MEGA VORTEX**



**VORTEX**



**VORTEX/B**

**INTENTIONALLY LEFT BLANK**

# CONTENTS

<b>1</b>	<b>SPECIFICATIONS</b> .....	Page 1
<b>2</b>	<b>PARTS LIST</b> .....	Page 4
<b>3</b>	<b>INSTALLATION &amp; ASSY PROCEDURES</b> .....	Page 5
<b>4</b>	<b>POST INSTALLATION INSPECTION</b> .....	Page 10
	<b>Appendix A: INTERNAL SWIVEL JOINT (CODE 87700305)</b> .....	Page 1
	<b>Appendix B: TYRE SEAT ASSEMBLY (87508101)</b> .....	Page 1
<b>1</b>	<b>SHACKLE REMOVAL</b> .....	Page 1
	<b>Appendix C: BASKET SEAT ASSEMBLY (87508201)</b> .....	Page 1
<b>1</b>	<b>SHACKLE REMOVAL</b> .....	Page 1

**INTENTIONALLY LEFT BLANK**

# 1 SPECIFICATIONS

REFERENCE		VORTEX	VORTEX/B
HEIGHT (H1)	m		2.216
DIAMETER (D1)	m		5.820
SEAT HEIGHT (h)	m		0.690
WEIGHT	kg		356.000
HEAVIEST PART (SWIVEL JOINT ASSEMBLY)	kg		82.000
LARGEST PART L x W x H (LEG ASSEMBLY)	m		4.070 x 2.200 x 0.300
CONCRETE	m <sup>3</sup>		1.16
MINIMUM SPACE DIA x H *	m		Ø8.280 X 4.355
MAX FREEFALL HEIGHT (H2)	m		1.400
FALLING SPACE AREA (FLUSH RUBBER)	m <sup>2</sup>		31.0
FALLING SPACE AREA (LOOSE FILL)	m <sup>2</sup>		41.6
RUBBER TILES 1m x 1m			35
MANHOURS	hr		24
MANPOWER			4
CONSTRUCTIONAL SPACE	m		Ø10

\* As well as the requirements of EN1176, SMP have included 1 metre spacing all round in addition to the Rubber Surface Falling Space Area

**NOTE:** All dimensions in metres.

Concrete mix is recommended at:  
 1 part cement;  
 2 parts sand;  
 4 parts aggregate;  
 by volume with 20mm aggregate  
 (20 N/mm<sup>2</sup> min compressive strength )

SMP Playgrounds Ltd recommends an effective *Impact Absorbing Surface tested to EN1177 & BS7188* beneath **all** play equipment. Refer to manufacturers instructions for details of installation. The surface should have a Critical Fall Height greater than the Maximum Freefall Height of the equipment.

Constructional Space (shown in the above table) is the approximate working area required to lay out and assemble the equipment.

Care should be taken when siting this equipment in order to discourage users in the surrounding area from unintentionally coming into contact with the equipment. This can be achieved, for example by placing the equipment at the perimeter of the play area.

For the safe operation of this equipment it must be installed on horizontal ground with the required minimum space.

The concrete foundations indicated are for average ground. Care should be taken concerning abnormal conditions.

**Tools:** Step ladder, 10m tape measure, Plumb Line, Spirit level, M16 Tap & handle, M10 Torx tool (Supplied with unit), M6 Torx tool (Supplied with unit), 10mm A/F Allen key, 16mm A/F Socket, Extension bar, Torque wrench.

**Lifting Equipment:** 9m Telehandler c/w 2 man basket, 3 x 1.5m lifting slings, 2m of Ø8 nylon rope,

**NOTE:** It is recommended that the above lifting equipment be used at all times when installing this piece of equipment.

**Minimum Personal Protective Equipment:-** Hard hat, Gloves, Armoured boots.

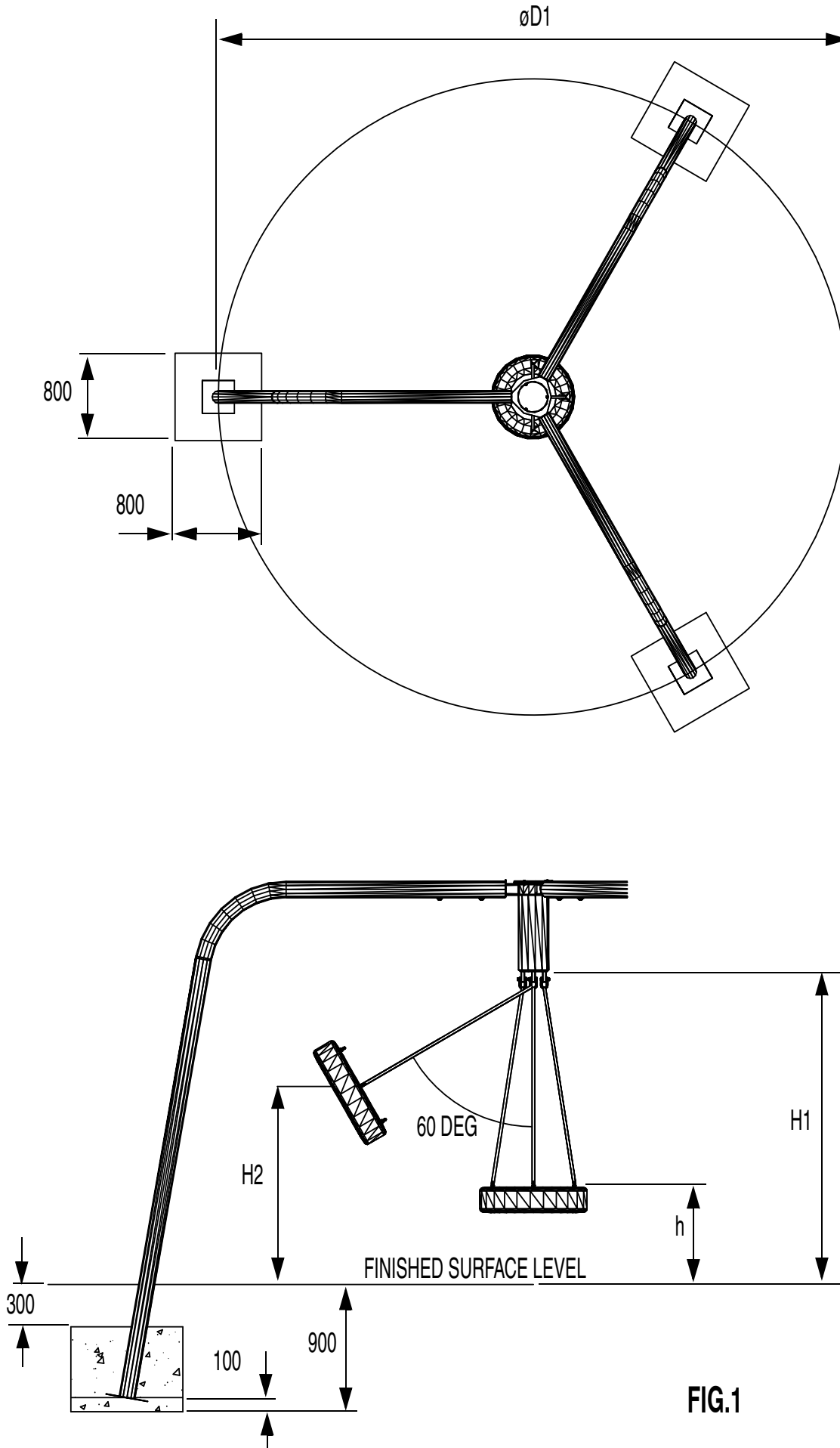
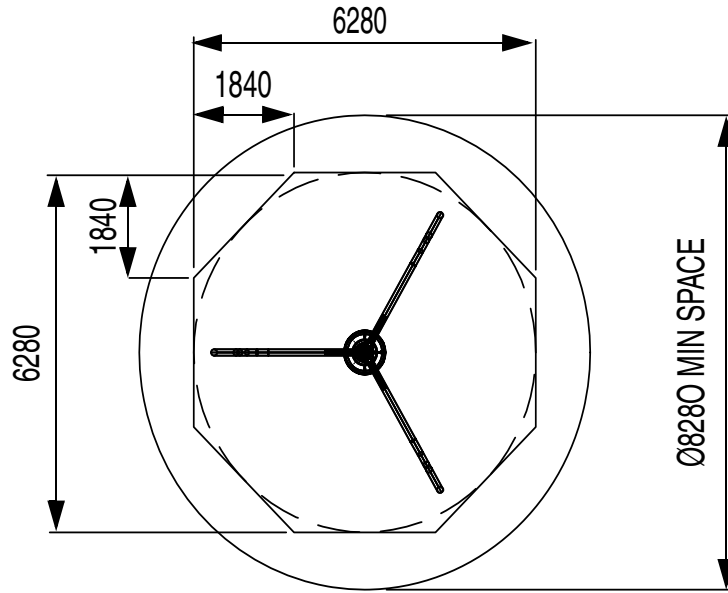
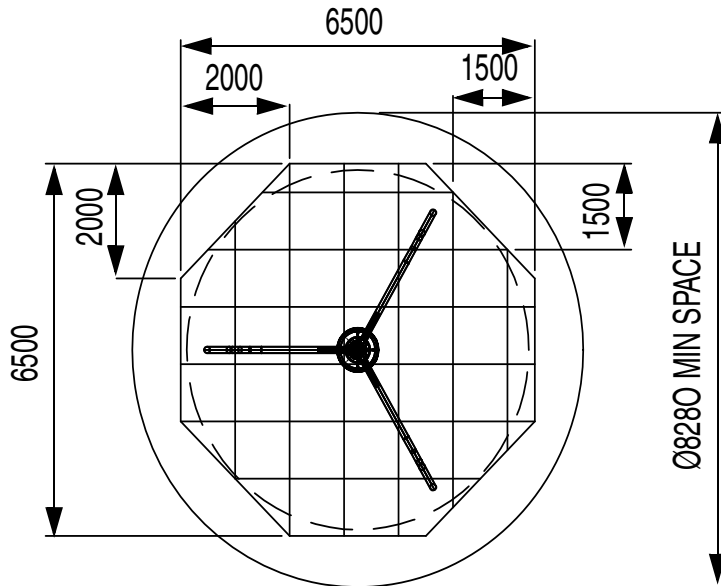


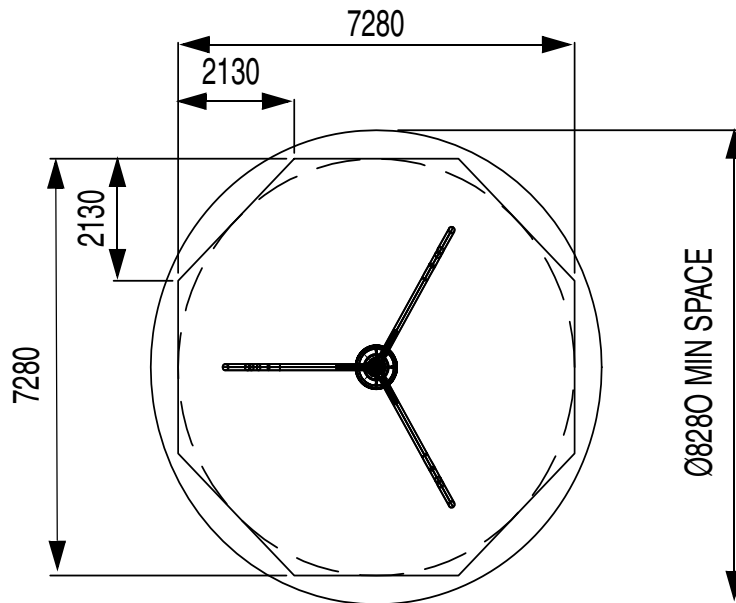
FIG.1



WET POUR AREA



TILED AREA



LOOSE FILL AREA

**FIG.2**  
SUFACING AREAS

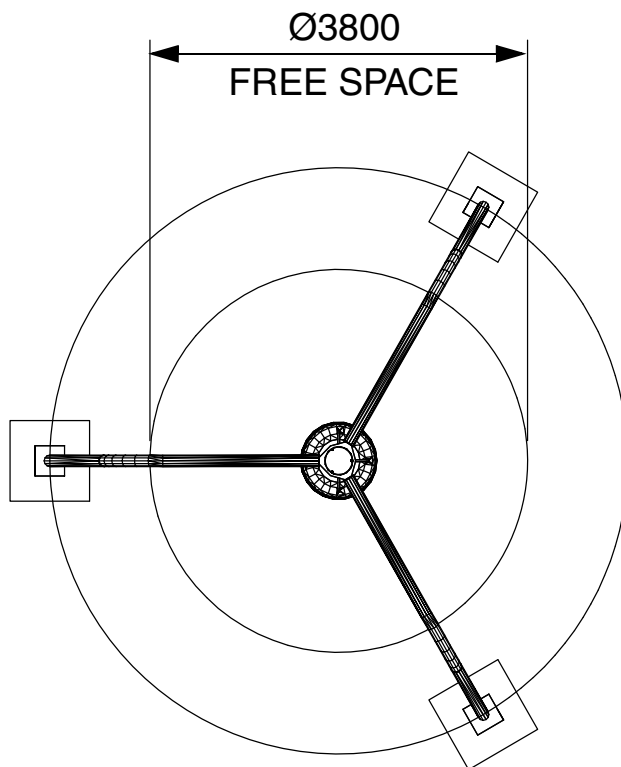


FIG.3

## 2 PARTS LIST

UN-ASSEMBLED COMPONENTS					
ITEM	CODE	DESCRIPTION	VORTEX	VORTEX/B	WEIGHT(kg)
1.1	87700801	LEG ASSEMBLY		3	78.000
1.2	87700301	SWIVEL JOINT ASSY		1	106.000
1.3*	87508101	TYRE SEAT ASSEMBLY*	1		40.000
1.4**	87508201	BASKET SEAT ASSEMBLY**		1	45.40
1.5	10141650	BUTTON HEAD SCREW M16 x 50		6	0.060
1.6	10291600	WASHER M16		6	0.004
1.7	15711200	EYEBOLT M12		3	0.200
1.8	10271200	HEX NUT M12		3	0.025
1.9	10291200	WASHER M12		3	0.008
-	10121000	M10 TORX TOOL		1	-
-	10120600	M6 TORX TOOL		1	-

\* SEE APPENDIX 'B' FOR PT. No. BREAKDOWN

\*\* SEE APPENDIX 'C' FOR PT. No. BREAKDOWN

### 3 INSTALLATION & ASSY PROCEDURES

#### SAFE WORKING PRACTICE:

A full risk assessment should be carried out prior to commencing the installation, which will be specific to the site selected. The major risks associated with purely the assembly of this product are highlighted below, which can form part of this overall assessment.

#### RISKS:

- i) Large heavy parts which could be difficult to lift or handle.

#### CONTROL MEASURES:

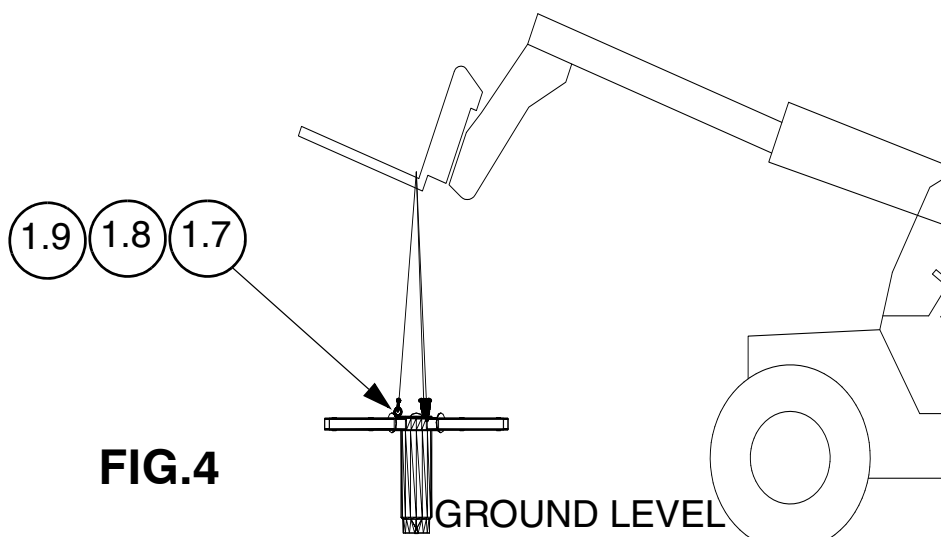
- i) Mechanical help to be utilised for awkward lifting. (Lifting eyes on the Swivel Joint assembly are provided for a secure lifting point. See section Lifting Equipment for other requirements.)

#### PRE-INSTALLATION INSPECTION

Inspect all parts for damage (that may have occurred during transportation & storage). Finish Coatings, if found to be damaged these should be made good before erection (Refer to maintenance instructions). Any damaged or missing parts must be replaced.

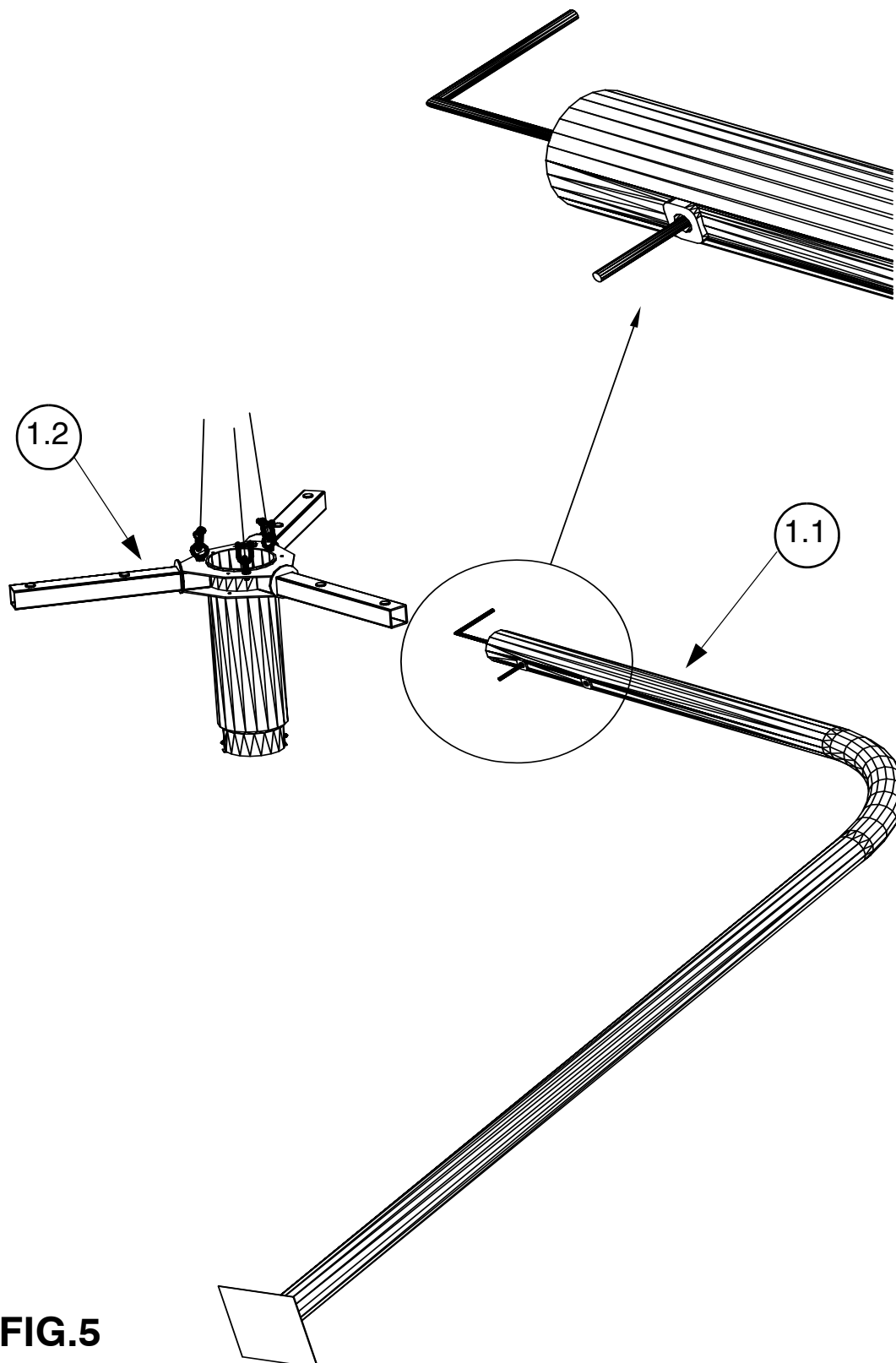
- i) Warn the public of the risk of injury, by placing signs and fencing the surrounding area, before commencing installation.
- ii) Mark out foundations and excavate the hole. (FIG.1). (refer to site plan for unit location).
- iii) Remove polyethylene cover from top of Swivel joint Assembly by removing 3 off M6 x 20 Resistorx bolts and M6 washers. Safely set aside these items for re-attachment in due course. (Ensure the M6 Tee nuts located within the cover do not become dislodged).
- iv) Fit 3 off M12 eyebolts (item 1.6), M12 washers (item 1.8) and M12 Hex nut (item 1.7) to top plate of Swivel Joint Assembly. (FIG.4)
- v) Ensure opening at top of unit is temporarily covered to prevent any ingress of weather or foreign bodies during installation.
- vi) Suspend Swivel Joint Assembly (item 1.2) from 9m Telehandler to just above ground level, using 3 off slings and 3 off shackles (Appendix B item 3.1) through eyebolts in top of unit, positioning at the centre of the 3 excavations for the legs. Ensure unit is stable and can not slip. (FIG.4).

**NOTE: When handling the Swivel Joint assembly it should never be stood on it's end or be subjected to any shock loads in an upwards direction on the rotating joint. (Do not drop this item - handle with care). As a precaution it is supplied with a transportation protector around the rotating lugs. This should not be removed until the installation is complete, prior to fitting the seat assembly..**

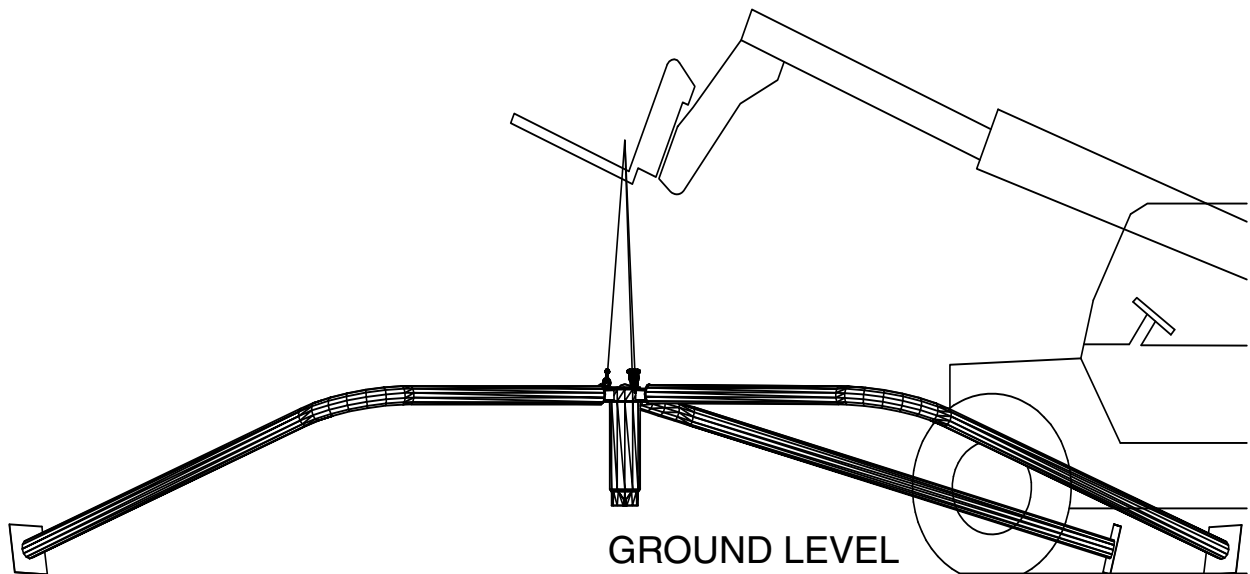


**FIG.4**

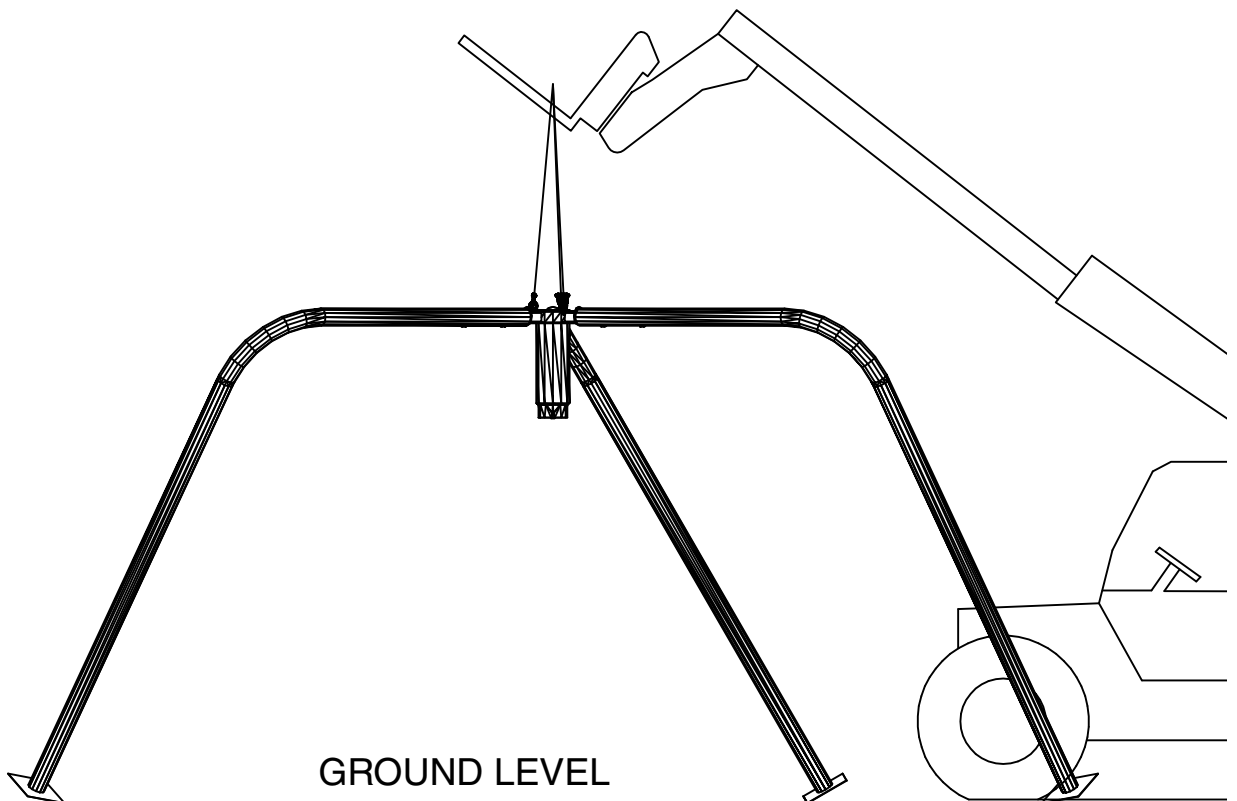
- vii) Thread one end of the Ø8 rope through end fixing hole in Leg Assembly (item 1.1) and out through the end of the leg. With Leg Assembly on it's side slide the it over end of Swivel Joint Assembly leg, making sure the rope will run freely, and rest the foot of the leg on the ground. **Note: These items are very heavy, and should be lifted by a minimum of three people.** (FIG.5)

**FIG.5**

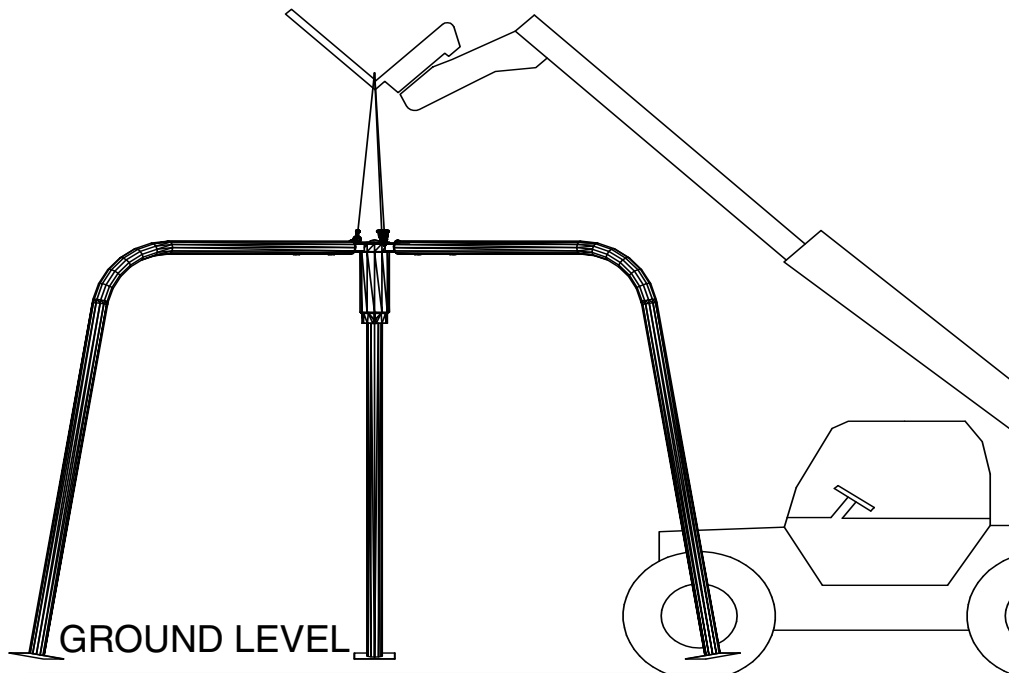
- viii) Thread rope through second Leg Assembly in the same way and place in position as the first.
- ix) Repeat as above for final Leg Assembly.
- x) With all Leg Assemblies in position the rope can be tied off around the Swivel Joint Assembly column to prevent the legs from sliding off during lifting. (FIG.6)

**FIG.6**

- xi) With one person attending each leg to stabilise it and to assist it's rotation the whole unit can then be slowly lifted. (FIG.7)

**FIG.7**

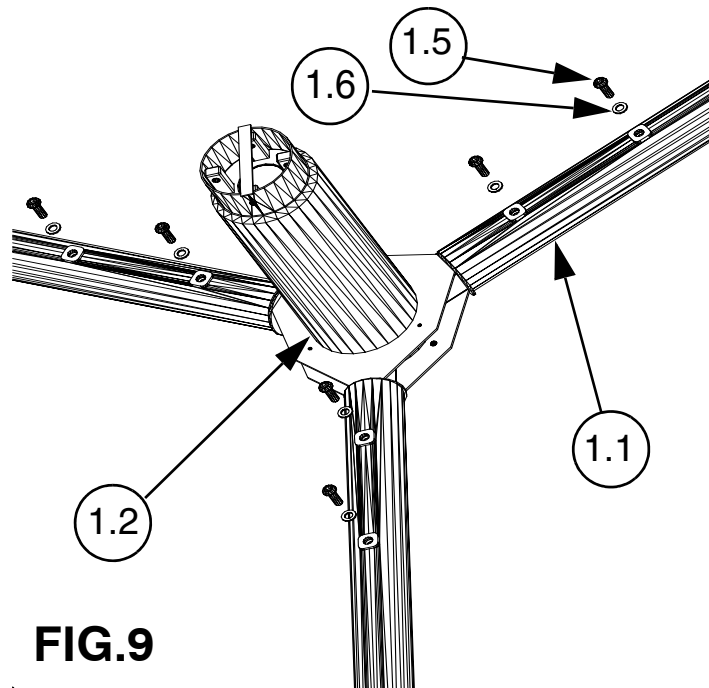
- xii) Continue lifting so that the legs can rotate round on their mounting until they are free to hang in their fixing position. (FIG.8)



**FIG.8**

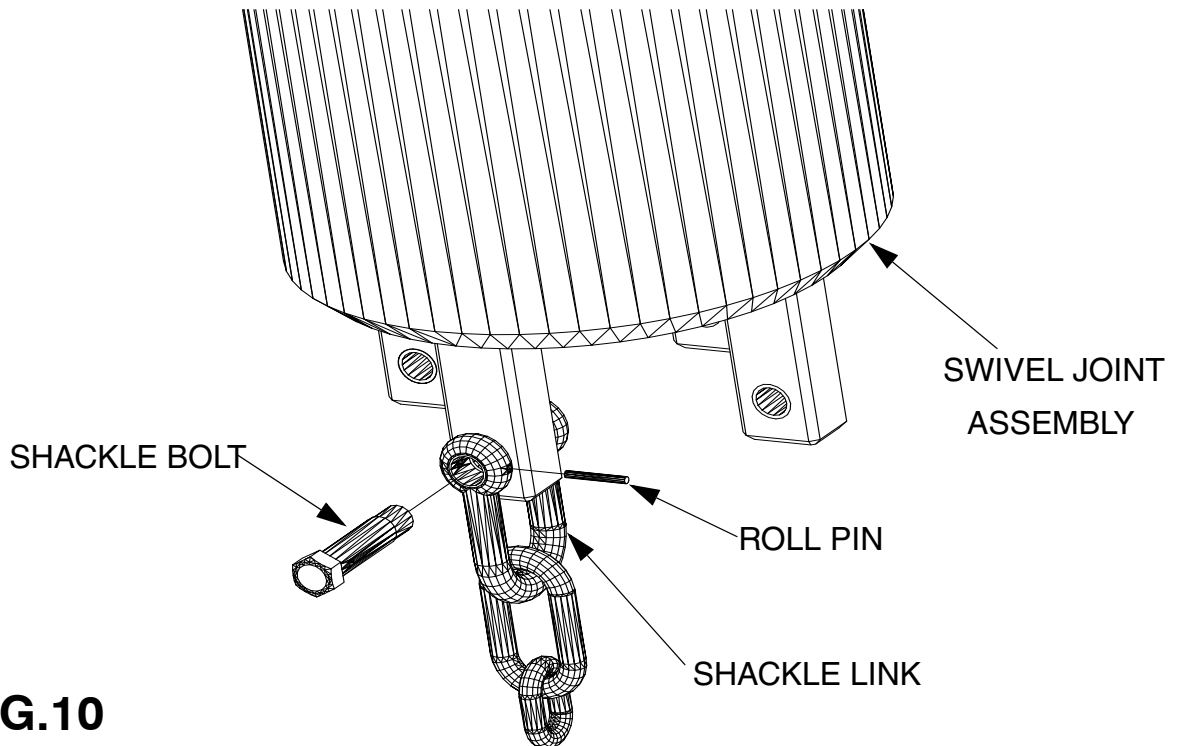
- xiii) Loosely secure each Leg Assembly (item 1.1) in position with 1-off M16 x 50 Button Hd Screw (item 1.4) and washer (item 1.5) in outer fixing positions only. Remove retaining rope from the Leg Assemblies and then fit the remaining M16 x 50 Button Hd Screws and washers in the inner fixing positions. Fully tighten to a torque of 225 Nm.(FIG.9).

**NOTE:** It is recommended to clean the threads with a M16 Tap prior to inserting the screws.



**FIG.9**

- xiv) Lower the unit until the legs sit in the excavated holes, pack up feet approximately 100mm or as required. Level and plumb line assembly into position checking with spirit level for horizontal. (Attaching the plumb line to the central yoke allows all legs to be checked individually).
- xv) Check M16 x 50 Button Hd Screw torque.
- xvi) Check height H1 from under side of Swivel Joint Assembly to finished surface level (FIG.1)
- xvii) Dismantle lifting slings, remove shackles and lifting eyebolts. Remove temporary cover from top of unit and refit the polyethylene cover to top of Swivel joint Assembly by using 3 off M6 x 20 Resistorx bolts and M6 washers.
- xviii) Fill the holes with concrete to the required level, taking into account any Impact Absorbing Surfacing requirements. Ensure that the full volume of concrete is used. The top should slope down & outwards locally from the equipment upstand to the required level to form a watershed.
- xix) Keep installation off limits to the public until the concrete has completely cured. (Recommended initial curing time is 48 hours).
- xx) Attach Tyre Seat Assembly (item 1.3) ensuring that each chain is not twisted and that the seat is level.
- xxi) Hand tighten the shackle bolt so that the hole in the bolt aligns with the hole in the shackle. Fit roll pin. Ensure pin is fully home with no projecting ends. (FIG.10).

**FIG.10**

## 4 POST INSTALLATION INSPECTION

CHECK	CHECK	✓
1 The unit is installed at the correct height. - See FIG.1	<input type="checkbox"/>	
2 Seat is installed at the correct height (Minimum seat ground clearance 400mm).	<input type="checkbox"/>	
3 Seat is level	<input type="checkbox"/>	
4 Chains are not twisted	<input type="checkbox"/>	
5 Roll pins are inserted	<input type="checkbox"/>	
6 Swivel joint assembly bearings revolve freely	<input type="checkbox"/>	
7 Swing shackles move freely	<input type="checkbox"/>	
8 All fixings are tightened to the correct torque and have no protruding sharp edges.	<input type="checkbox"/>	
9 Paint work is not damaged	<input type="checkbox"/>	
10 The polyethylene weather cover on top of the unit is fitted correctly and not damaged.	<input type="checkbox"/>	
11 Concrete foundations are secure.	<input type="checkbox"/>	
12 Adequate provision of Impact Absorbing Surfacing with no obstructions or other hazards within the equipments minimum space.	<input type="checkbox"/>	
13 Site is clear of all tools and rubbish.	<input type="checkbox"/>	
14 Remove any warning signs.	<input type="checkbox"/>	
15 Lifting eyebolts, nuts and washers and transportation protector have been passed to whoever is responsible for the maintenance of the unit.	<input type="checkbox"/>	

---

## Appendix A: INTERNAL SWIVEL JOINT (CODE 87700305)

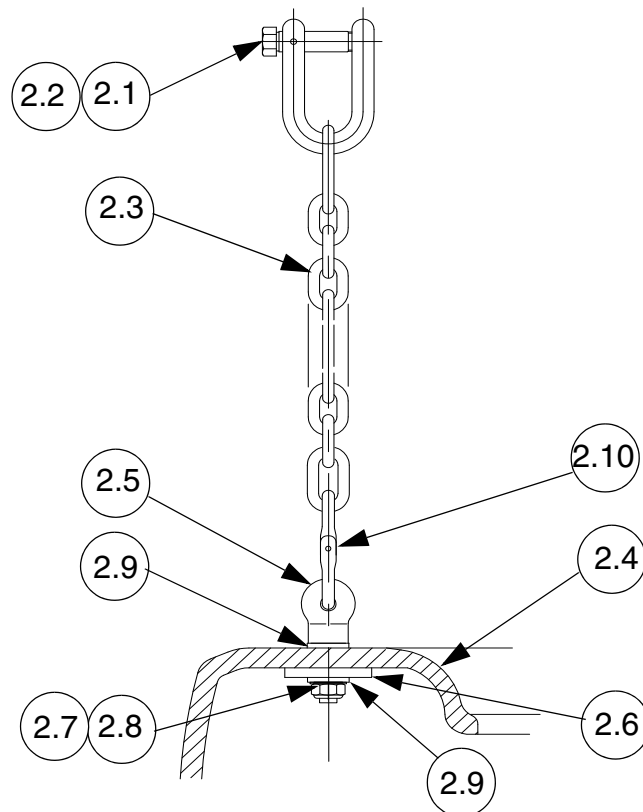
The bearings used in this item of equipment are sealed for life. If the bearings should become damaged or need replacing, then the whole Internal Swivel Joint will need to be replaced. **The replacement of this unit must be done by an SMP engineer.** Any work carried by a SMP engineer will be done on the basis of installing an exchange unit.

**INTENTIONALLY LEFT BLANK**

## Appendix B: TYRE SEAT ASSEMBLY (87508101)

The assembly described below is for the tyre seat assembly. This will be supplied complete by SMP. Instructions are included should the unit need to be dis-assembled.

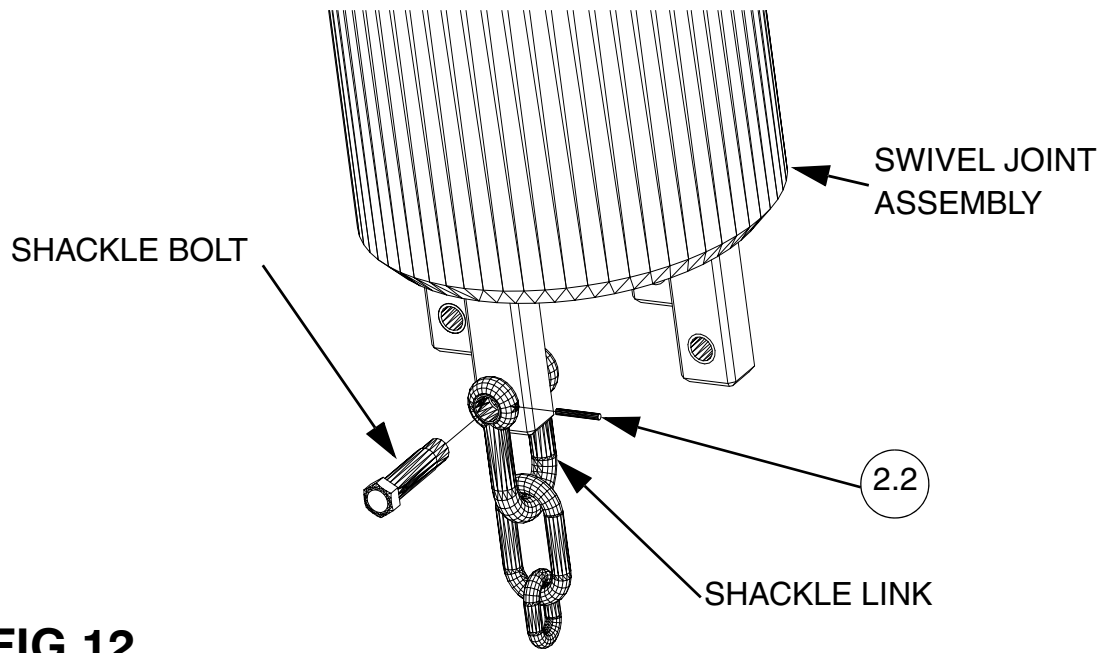
ASSEMBLED COMPONENTS				
ITEM	CODE	DESCRIPTION	QTY.	WEIGHT (kg)
2.1	88096003	SHACKLE ASSEMBLY	4	0.300
2.2	10310325	ROLL PIN	4	0.001
2.3	87508102	CHAIN SET (4 PIECES)	1	15.000
2.4	19010445	TYRE SEAT	1	19.000
2.5	15711010	EYEBOLT	4	0.002
2.6	87508103	TYRE SEAT SUPPORT	4	0.540
2.7	10291000	WASHER - M10	4	0.001
2.8	10261000	NYLOC NUT - M10	4	0.020
2.9	10303212	WASHER T5 - M10	8	0.001
2.10	15715000	COUPLING LINK	4	0.100



**FIG.11**

### 1 SHACKLE REMOVAL

- i) Tap out roll pin (item 2.2) using suitable punch from shackle assembly (item 2.1). (FIG.12)
- ii) Unscrew shackle bolt and remove from shackle. (FIG.12)
- iii) Repeat for other three chains.

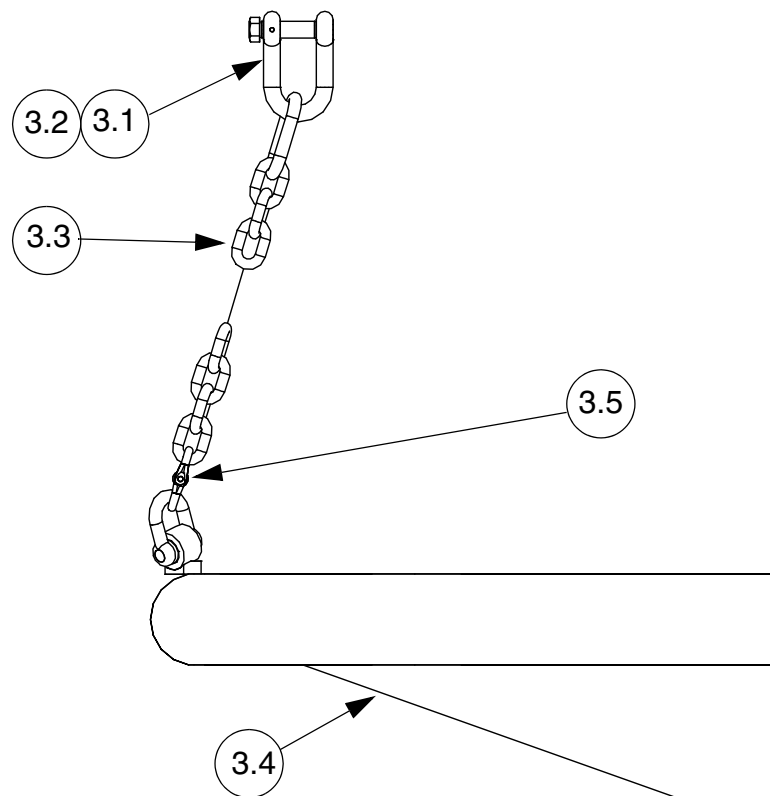


**FIG.12**

## Appendix C: BASKET SEAT ASSEMBLY (87508201)

The assembly described below is for the tyre seat assembly. This will be supplied complete by SMP. Instructions are included should the unit need to be dis-assembled.

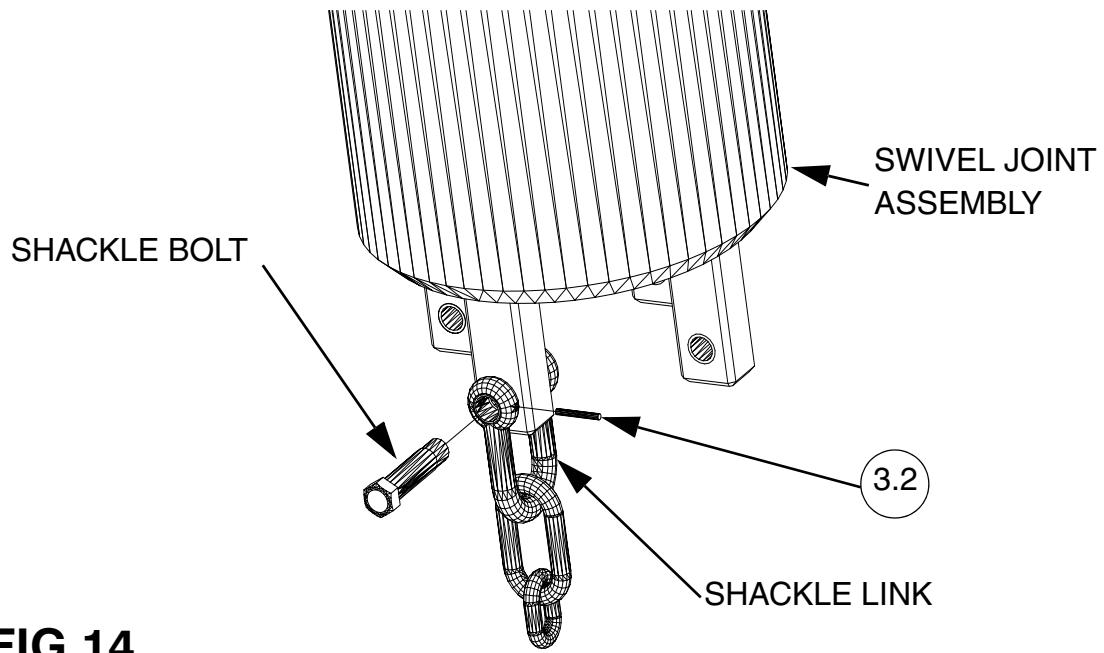
ASSEMBLED COMPONENTS				
ITEM	CODE	DESCRIPTION	QTY.	WEIGHT (kg)
3.1	88096003	SHACKLE ASSEMBLY	4	0.300
3.2	10310325	ROLL PIN	4	0.001
3.3	87508102	CHAIN SET (4 PIECES)	1	15.000
3.4	89008103	BASKET SEAT	1	30.00
3.5	15715000	COUPLING LINK	4	0.100



**FIG.13**

### 1 SHACKLE REMOVAL

- i) Tap out roll pin (item 3.2) using suitable punch from shackle assembly (item 3.1). (FIG.14)
- ii) Unscrew shackle bolt and remove from shackle. (FIG.14)
- iii) Repeat for other three chains.



**FIG.14**