

## A Assembly Instructions for Artist combination, Art. 20.01.030



**Revision history**

Revision 0 – 2004-09-24

First approved version

Assembly instructions

Revision 1 – 2008-05-30

All rights reserved.

© Copyright 2003 Spogg Sport-Güter GmbH

## Contents

<b>A</b>	<b>Assembly Instructions for Artist combination, Art. 20.01.030</b> .....	<b>1</b>
1	Introduction Assembling .....	4
2	Datasheet Artist combination, article 20.01.030 .....	5
3	Delivery contents (parts list with part numbers) .....	6
4	Erection instructions .....	8
5	Post installation checks .....	14
<b>B</b>	<b>Maintenance Instructions for Artist combination, Art. 20.01.030</b> .....	<b>15</b>
6	Introduction Maintenance.....	17
7	General maintenance information .....	18
7.1	Maintenance intervals.....	18
7.2	Inspection frequency.....	18
7.3	Maintenance products and procedures.....	18
7.4	Spare parts.....	18
7.5	Identifying spare parts .....	18
7.6	Special instructions for the disposal of individual equipment components .....	18
7.7	Special measures during the break-in period.....	18
7.8	Drainage holes .....	<b>Error! Bookmark not defined.</b>
7.9	Maintenance of protective surfaces .....	18
7.10	Faults .....	19
7.11	Loose screws.....	19
7.12	Preventing equipment use .....	19
7.13	Safeguarding the guarantee .....	19
8	Specific maintenance advice.....	<b>Error! Bookmark not defined.</b>
9	Maintenance timetable.....	<b>20</b>
10	Monthly maintenance.....	<b>22</b>
11	Quarterly maintenance.....	<b>22</b>
12	Annual maintenance .....	<b>23</b>
13	Maintenance printout.....	<b>25</b>
14	Hand over document.....	<b>27</b>

## List of Tables

Table 3-1: Delivery contents, in words .....	6
Table 3-2: Delivery contents, in symbols .....	7

---

# 1 Introduction Assembling

## 1.1 General information

This equipment should be installed, inspected, maintained and operated in accordance with EN1176-7 guidelines.

**Before installation work commences, please check that you have all of the equipment and fixation components in the parts list provided (see Tables 3-1 and 3-2).**

Any spare parts that may be required can be obtained directly from your supplier.

Please do not hesitate to call us on **01308 425100** if you have any problems during installation or with any other questions.



**Attention**

Following installation, complete assembly instructions, maintenance instructions and a maintenance record must be sent to the operator who must confirm receipt in writing. See the last page of this document.



**Attention**

All nuts and bolts are hot-dip galvanised or stainless steel. One of the characteristics of stainless steel is that uncontrolled cold welding may occur when the nuts are tightened. To prevent this, it is necessary to spray the nuts and bolts with Teflon spray or another similar lubricant.

---

**We hereby confirm that this play equipment has been tested and certified in accordance with the play equipment standard EN 1176.**

## 2 Datasheet Artist combination, article 20.01.030

1. Space requirement: Ø 3.50 m and/or Ø 11.00 m including safety zone, height of fall 2.00 m
2. Required safety surface:

Surface material	Description mm	Minimum thickness of layer mm	Maximum height of fall mm
Topsoil grass			<= 1000*
Chipped bark	20 – 80 grain size	400	<= 3000
Wood chippings	5 – 30 grain size	400	<= 3000
Sand	0.2 – 2 grain size	400	<= 3000
Gravel	2 – 8 grain size	400	<= 3000
Other ground materials	As recommended by manufacturer	400	

3. Name and overall dimension of the largest component:  
Steel post (1 item) length 3.80m, Ø 193 mm
4. Name and weight of the heaviest component:  
Rotation element (1 item), 110 kg
5. Intended age group: 5 years and over
6. **Please note that this equipment is set in concrete.**  
Concrete: B25 – C20/25  
Required concrete: approx. 1.15 m<sup>3</sup>  
Foundations/area to be excavated:  
**1 x 1.20 m long x 1.20 m wide, total depth 1.10 m including 10 cm drainage**  
Top edge of concrete 40 cm below ground level.



Attention!

**Round off edges of concrete foundations!**

**Important – All sizes of foundations are valid for soil class 3 – 4 (standard soil). In case of sandy and soft soil we strictly recommend to enlarge the foundation dimensions.**

- 7.
8. Assembly time, once foundations complete: approx. 3 hours.  
Required assistance: 2 - 3 people.
9. Any spare parts which may be required can be obtained directly from your supplier
10. **We hereby confirm that this item of play equipment has been tested and certified in accordance with the play equipment standard EN 1176.**

### 3 Delivery contents (parts list with part numbers)













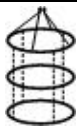

#### 3.1 In words

Table 3-1: Delivery contents, in words

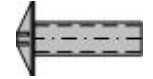
Pos.	Quantity	Element / Description	Size	O.K.	Missing
1	1	Steel mast	3.80 m long, Ø 193 mm		
2	1	Rotating seesaw mechanism			
3	4	Red caps	for Ø 140 mm		
4	1	Play part Item No. 20.03.030			
5	1	Play part Item No. 20.03.040			
6	1	Play part Item No. 20.03.050			
7	1	Play part Item No. 20.03.060			
8	4	Glue binder	1.65 m long, Ø 140 mm		
100	12	Wood screws	5 x 30 mm		
101	4	Sleeve nut pre-assembled (for suspension support)	M12		
102	4	Suspension support (similar to 4608-2 swivel VA) pre-assembled	M12		
103	8	Caps (black)	for M10		
104	8	Hexagonal wood screws	10 x 100		
105	1	Cap nut VA, DIN 1587	M16		
106	4	Hexagonal nut VA, DIN 985 (self locking)	M10		
107	4	Allen screw VA	M10 x 30		
108	1	Brake disk			

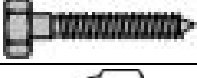
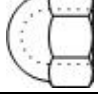
### 3.2 In symbols

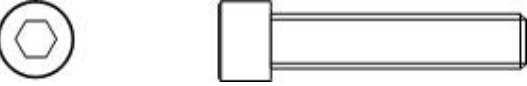
Table 3-2: Delivery contents, in symbols

Pos.	Quantity	Symbol
1	1	
2	1	
3	4	
4	1	
5	1	
6	1	
7	1	
8	4	
100	12	
101	4	
102	4	
103	8	
104	8	
105	1	
106	4	
107	4	
108	1	

## 4 Erection instructions

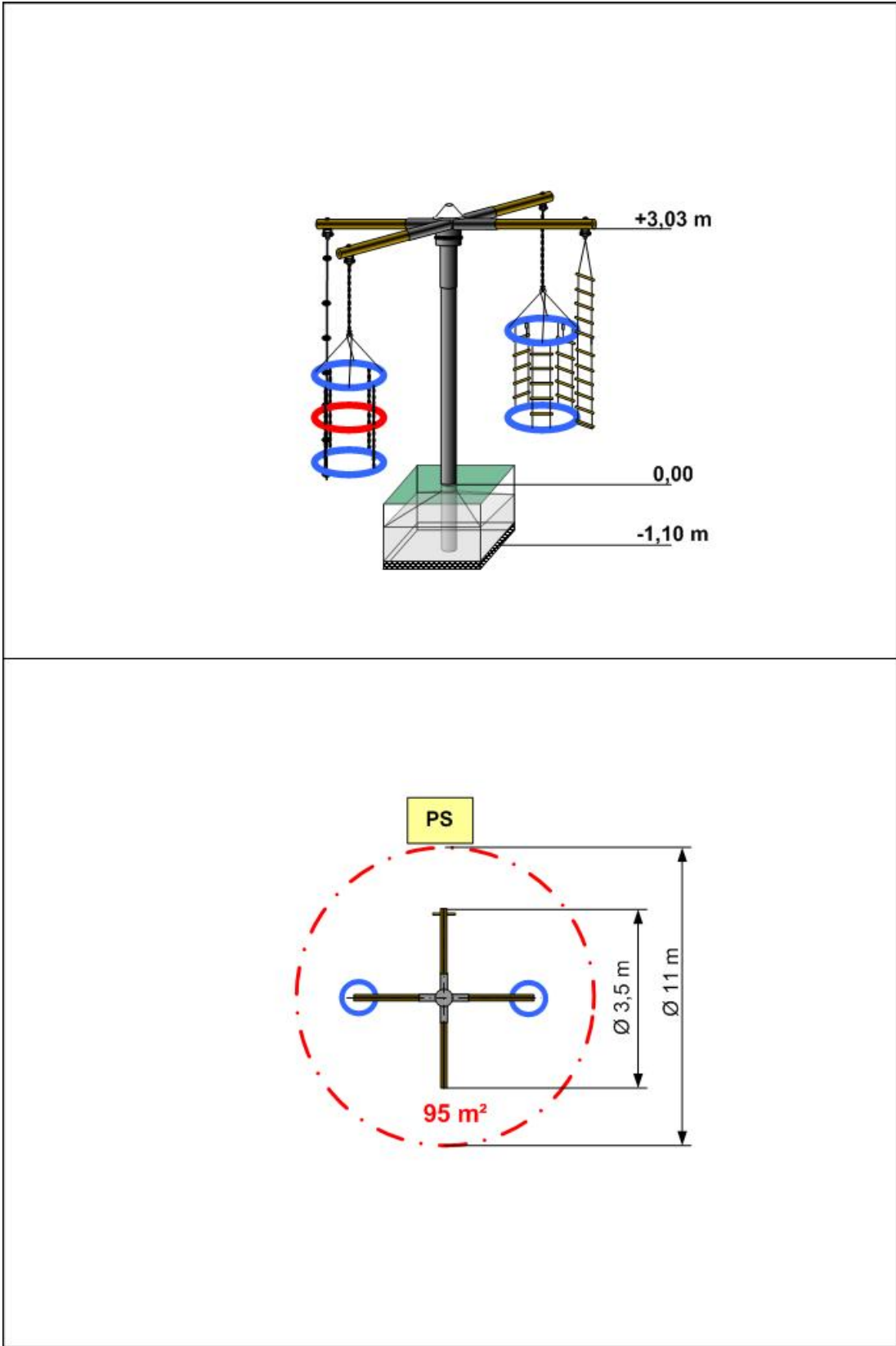

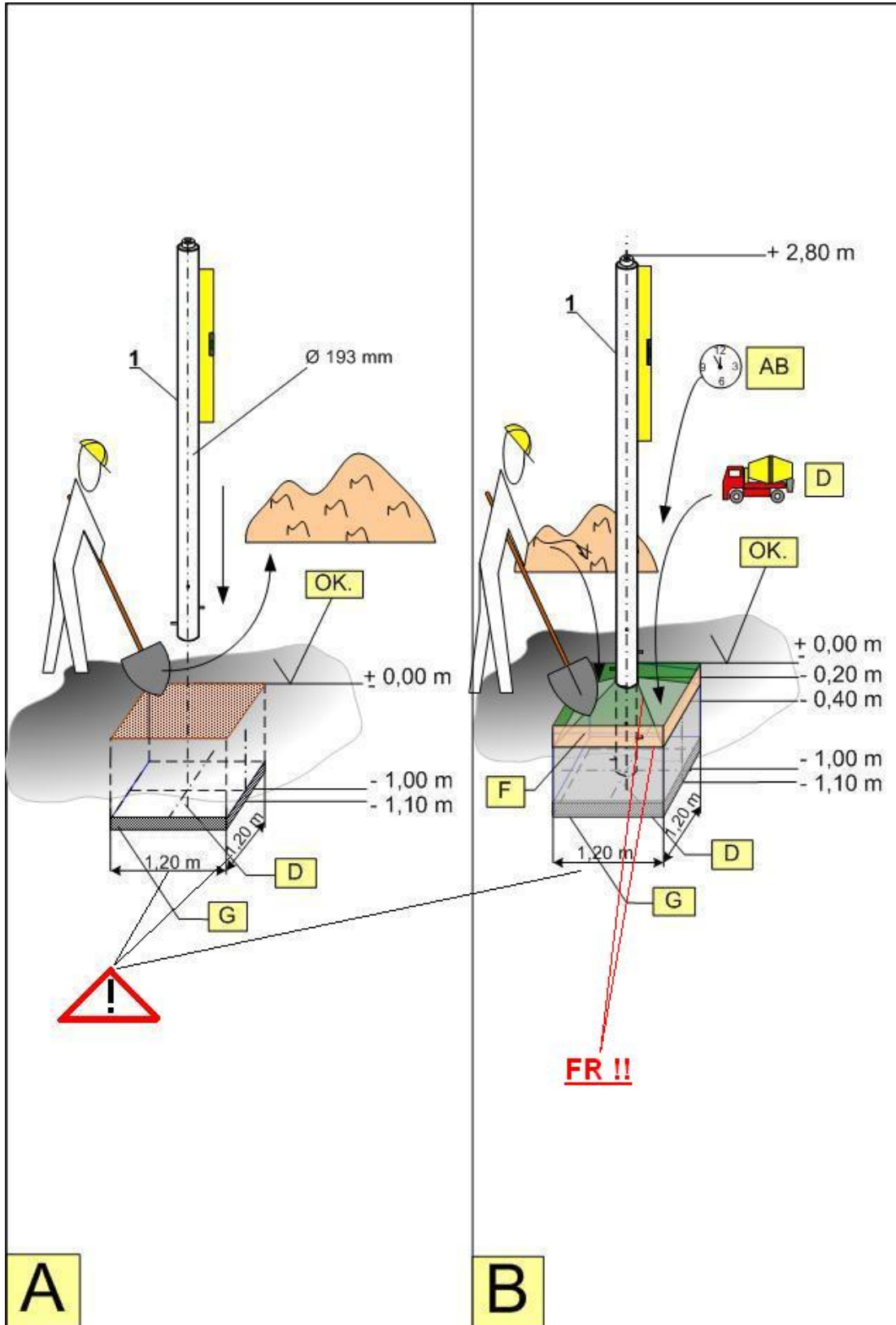

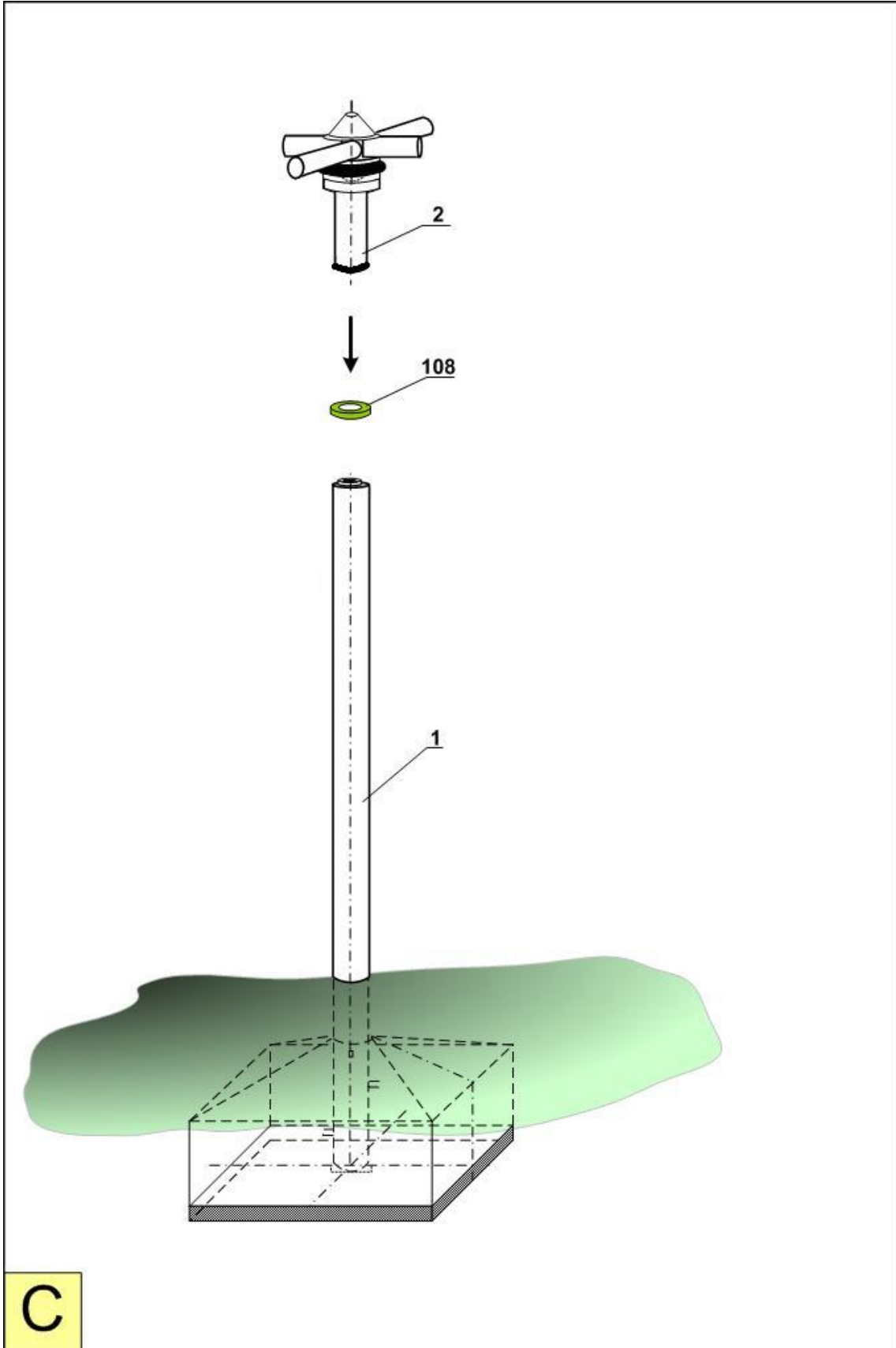

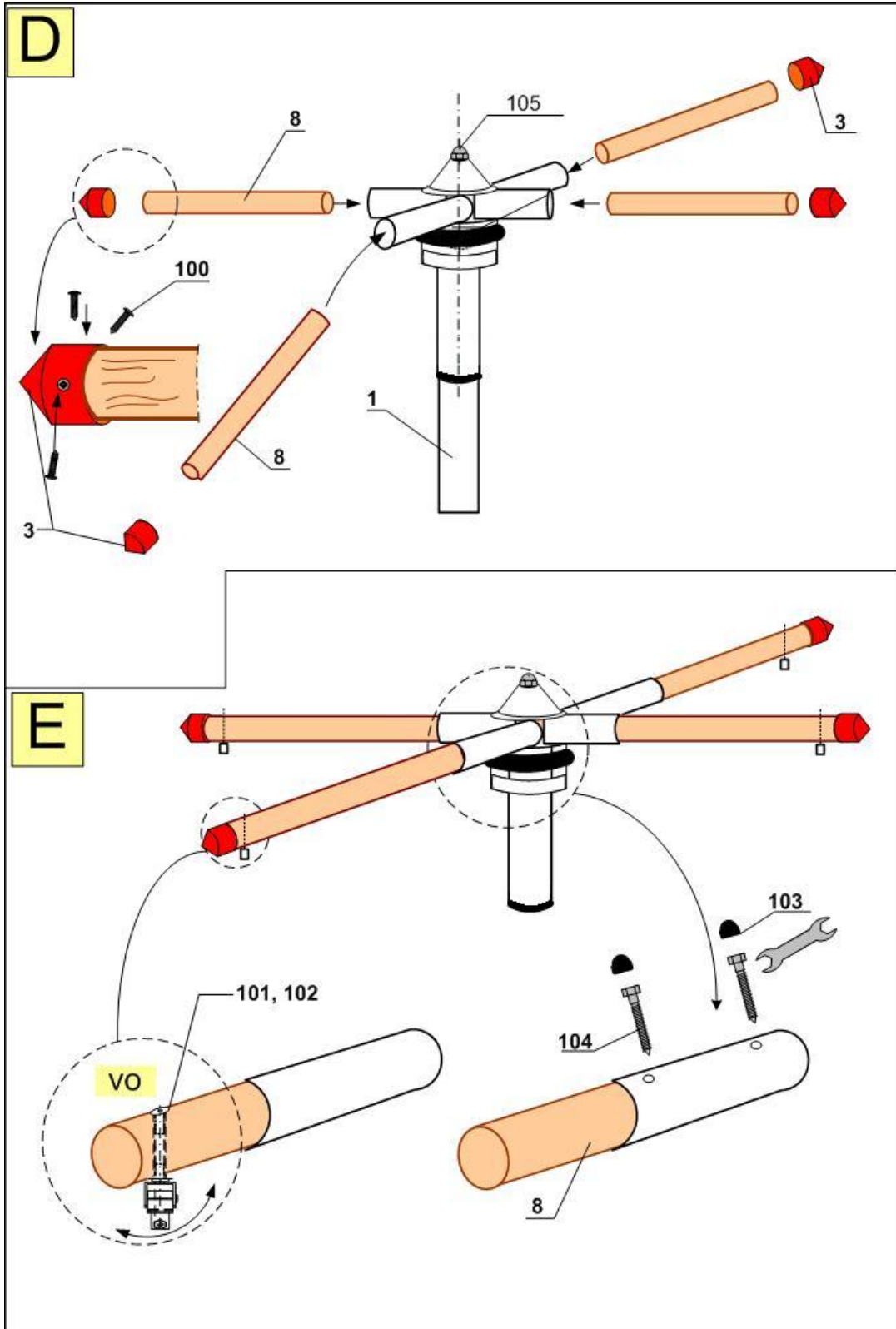

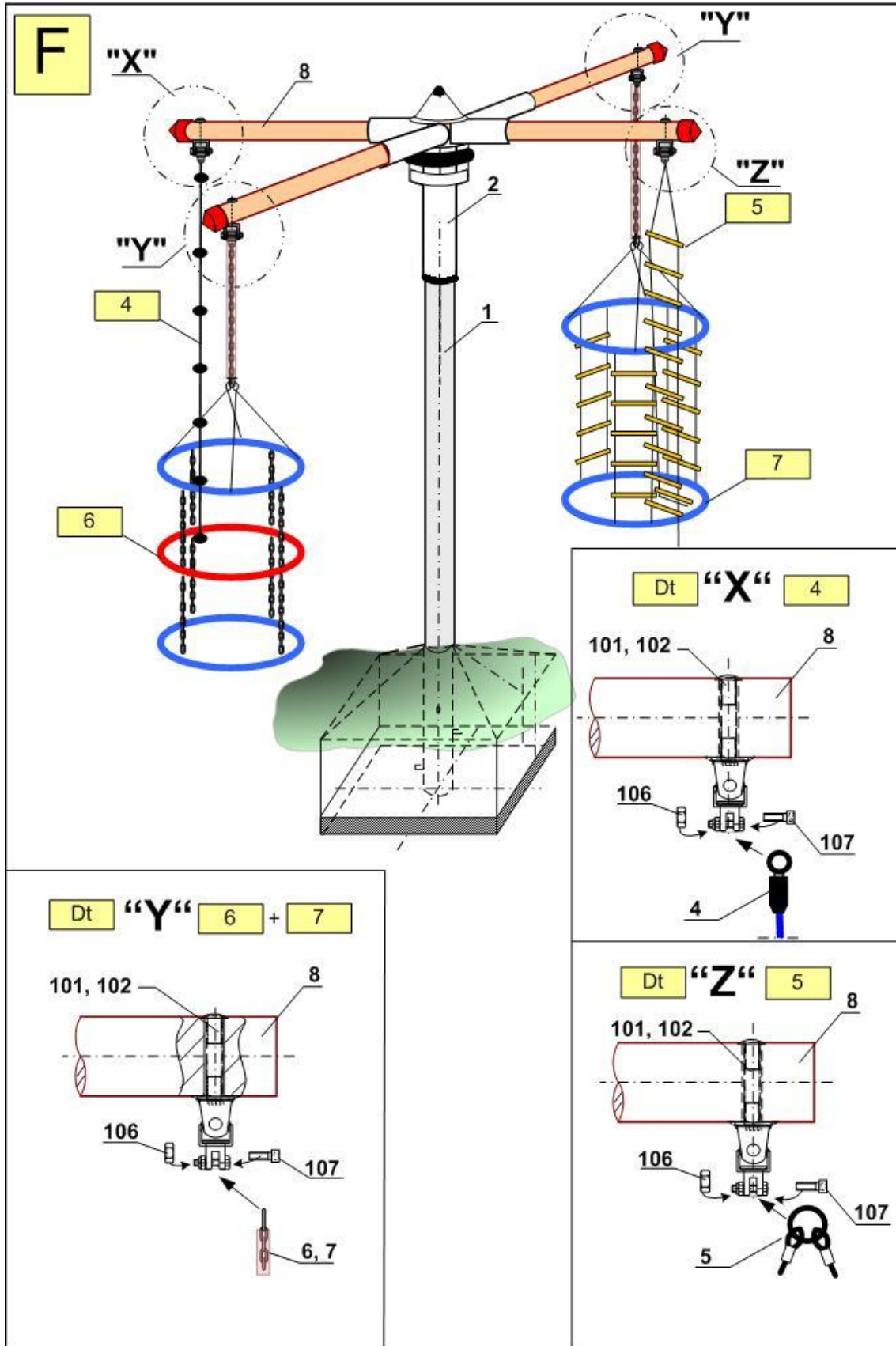

<b>AB</b>	Setting time for B25 – C20/25 at least 4 – 5 days
<b>D</b>	Concrete B25 – C20/25 Concrete requirement: 1.15 m <sup>3</sup>
<b>FR !!</b>	<b><u>Foudation radius at least 100 mm !</u></b>
<b>F</b>	Fall protection
<b>G</b>	Drainage
<b>M</b>	Minimum
<b>O.K</b>	Upper edge of playing level
<b>PS</b>	Minimum safetey area 95 m <sup>2</sup>
<b>vo</b>	Pre-assembled
	<b><u>Round off edges of concrete foundations!</u></b> <b><u>Important – All sizes of foundations are valid for soil class 3 – 4 (standard soil).In case of sandy and soft soil we strictly recommend to enlarge the foundation dimensions.</u></b>
<b>Dt</b>	Detail / specification

**See drawings**

---

## 5 Post installation checks

---



If the equipment has not been installed safely, you must ensure that the public is prevented from using it.

---

### 5.1 Marking filler depth

- Labelling the posts to show the depth of material provided as fall protection (i.e. loose filler).

### 5.2 The equipment has not been installed safely in the following cases:

- Safe equipment installation is not complete.
- The protective surface has not been installed yet.
- Appropriate maintenance work cannot guarantee operational safety.

### 5.3 Removal of all assembly aids

- Please make sure that all assembly aids have been removed from the playing area. The equipment must not be approved for use until this check has been made.

### 5.4 Information about inspection of the equipment before it is used for the first time

- There are no special inspection requirements to be met before the equipment is used for the first time.

### 5.5 Retighten bolts

- After one week of play, please retighten all bolts again. Later upon respective maintenance.

## **B Maintenance Instructions for Artist combination, Art. 20.01.030**



**Revision history**

Revision 0 – 2004-09-24

First approved version

Maintenance instructions

Revision 0 – 2008-05-30

All rights reserved.

© Copyright 2003 Spogg Sport-Güter GmbH

---

## 6 Introduction Maintenance

### 6.1 General informations

This equipment should be installed, inspected, maintained and operated in accordance with EN 1176-7 guidelines.



**Please note:** Providing any necessary repairs are carried out, a piece of play equipment that is inspected regularly cannot become so damaged that it is dangerous.

---

Any spare parts which may be required can be obtained directly from your supplier.



This equipment should only be assembled, maintained and repaired by **persons with the necessary expertise**.  
**A copy of the inspection record should be given to the operator, who must confirm receipt.**

---

**This maintenance instruction is based on the standard  
“EN 1176-1:1998”.**

## **7 General maintenance information**

### **7.1 Maintenance intervals**

Maintenance intervals are based on average use. Please note that more frequent inspections and/or maintenance are required if the play equipment is subject to intensive use.

### **7.2 Inspection frequency**

The frequency of inspections must be based on actual use. Factors that affect frequency include vandalism, location (e.g. coastal proximity), air pollution and the age of the equipment.

### **7.3 Maintenance products and procedures**

All nuts and bolts are hot-dip galvanised or stainless steel. One of the characteristics of stainless steel is that uncontrolled cold welding may occur when the nuts are tightened. To prevent this, it is necessary to spray the nuts and bolts with Teflon spray or another similar lubricant.

### **7.4 Spare parts**

All spare parts must conform to the manufacturer's specifications.

### **7.5 Identifying spare parts**

All spare parts are listed in the parts list. The parts list follows the installation requirements.

### **7.6 Special instructions for the disposal of individual equipment components**

No special instructions are necessary for the disposal of individual equipment components.

### **7.7 Special measures during the break-in period**

No later than 2 weeks after assembly, all screwed connections should be checked and tightened if necessary.

### **7.8 Maintenance of protective surfaces**

Surfaces providing fall protection must also be maintained regularly. It is particularly important to maintain the correct level of loose surface material and add more if necessary.

---

## 7.9 Faults

---



Faults must be repaired as soon as they are detected. If serious defects that compromise safety cannot be repaired straight away, the public must be prevented from using the equipment with immediate effect.

---

## 7.10 Loose screws

---



Loose screws always cause quality problems and put safety at risk. Therefore, loose screws should always be tightened and checks carried out to ensure that there are no missing screws (e.g. look out for holes you can see through).

---

## 7.11 Preventing equipment use

Use of the equipment should be prevented in the event of incomplete installation, disassembly, maintenance, repairs and faults.

## 7.12 Safeguarding the guarantee

Steel posts and footings are guaranteed if regular maintenance is carried out and recorded in writing. Maintenance first takes place after 3 years. The steel posts must be excavated as far as the concrete foundations and checked for corrosion. Zinc paint should be applied to any corroded areas and scratches.

---

## 8 Maintenance timetable

### 8.1 Special advices

#### 8.1.1 Maintenance interval

We strongly advise you to carry out inspections and maintenance work within the specified periods as use of the equipment, the weather and malicious vandalism cause wear and tear that compromises the safety and function of the equipment.

#### 8.1.2 Maintenance intervals in the event of intensive use

Please note that more frequent inspections and/or maintenance are required if the play equipment is subject to intensive use.

#### 8.1.3 Faults that compromise safety

---



In the event of a fault that compromises safety, quick action must be taken. This may involve repairing it immediately or shutting down and dismantling the equipment.

---

#### 8.1.4 Faults that compromise function

---



Faults that compromise function should also be repaired immediately. Such faults lower the value of the equipment to the user and encourage malicious vandalism, which may render the equipment less safe. Any damage should also be repaired immediately.

---

## 9 Regular Maintenance

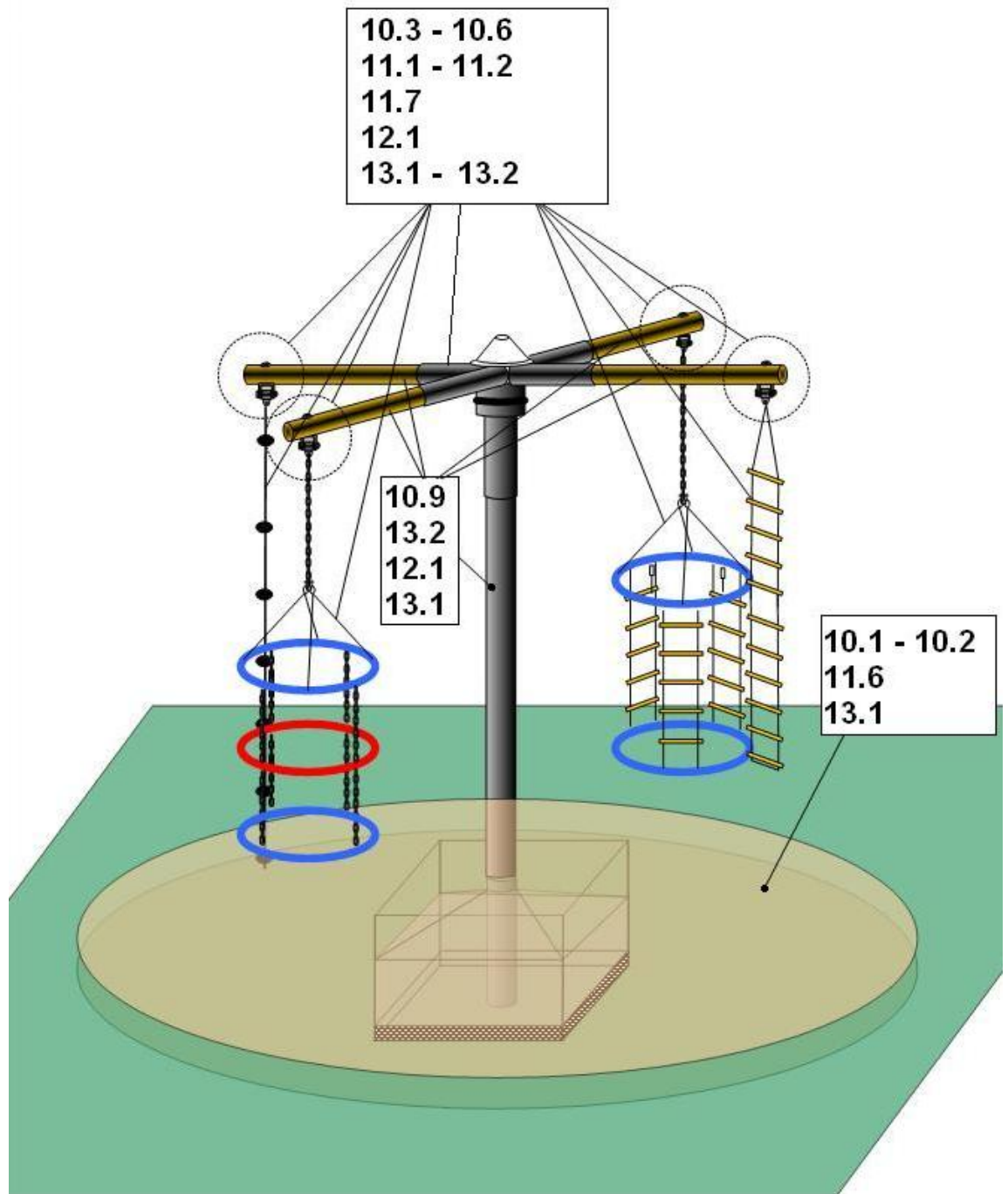

## **10 Monthly maintenance**

- 10.1 Check the spaces between the equipment and the ground (clearance and height of fall).**
- 10.2 Check the ground surface in the area with fall protection for hard objects and loose foundations.**
- 10.3 Check all connecting elements and fittings for wear and tear and tighten if necessary. Replace damaged or missing parts.**
- 10.4 Check that moving metal parts (joints, springs, etc.) move smoothly and are not worn. Replace if necessary. It is not necessary to lubricate joints as we only use maintenance-free metal roller bearings.**
- 10.5 Check all attachments such as chains, ropes, nets, etc. for damage and replace if necessary.**
- 10.6 Check rubber parts, sleeves, etc. for wear and tear or damage and replace if necessary.**
- 10.7 If necessary, remove excess padding material from the post footings due to danger of rotting.**
- 10.8 Check the surface of wooden parts for damage caused by the weather or external influences and mould. Repair or replace if necessary.**
- 10.9 Check the surface of plastic and metal parts, e.g. slides, for damage and replace if necessary.**

## **11 Quaterly maintenance**

- 11.1 Detailed inspection of the operation and stability of the equipment paying particular attention to any wear and tear.**
- 11.2 Tighten all forms of attachment.**
- 11.3 Repaint and retreat surfaces.**
- 11.4 Maintenance of fall protection surfaces.**
- 11.5 Lubrication of joints.**
- 11.6 Check the height of the fall and top up with loose filler if necessary. If the posts are labelled, top up as far as the mark.**
- 11.7 Retighten all bolts**

## **12 ½ Yearly maintenance**

- 12.1 Stability (check posts, bracing, foundations, etc.).**
- 12.2 Ascertaining whether there are any changes in equipment safety as a result of repairs that have been carried out or components that have been added or replaced.**



Attention

## Annual Maintenance

---

### 13 Annual maintenance

- 13.1 Ascertaining that the equipment, foundations and surfaces are safe for operation.
- 13.2 In particular, the equipment should be checked for decay and corrosion. It may be necessary to dig out or excavate certain components in order to do so. Zinc paint should be applied to corroded areas and scratches.



Attention

The equipment must be inspected by someone **with the necessary expertise** in strict compliance with the instructions issued by SPOGG Sportgüter GmbH

**A copy of the inspection record should be given to the operator, who must confirm receipt.**

---







---

## 15 Hand over document

---



After the installation of the equipment pass the installation and maintenance documents to the operator. The operator has to receive the hand over documents. The complete filled and signed hand over document should be sent to the supplier.

---

Art.-No.: 20.01.030

Type of item: Artist combination

Serial number: \_\_\_\_\_

**Customer or operator (Town, Town council, Kindergarten, etc.):**

\_\_\_\_\_  
\_\_\_\_\_

Competent person in charge:

\_\_\_\_\_  
\_\_\_\_\_

**Installation company (address):**

\_\_\_\_\_  
\_\_\_\_\_

Responsible assistant (assembler):

\_\_\_\_\_  
\_\_\_\_\_

Received the complete assembly instructions, maintenance instructions and maintenance printout .

\_\_\_\_\_

(Signature of operator)      (Signature of installation company)  
(Stamp)

Date: \_\_\_\_\_