

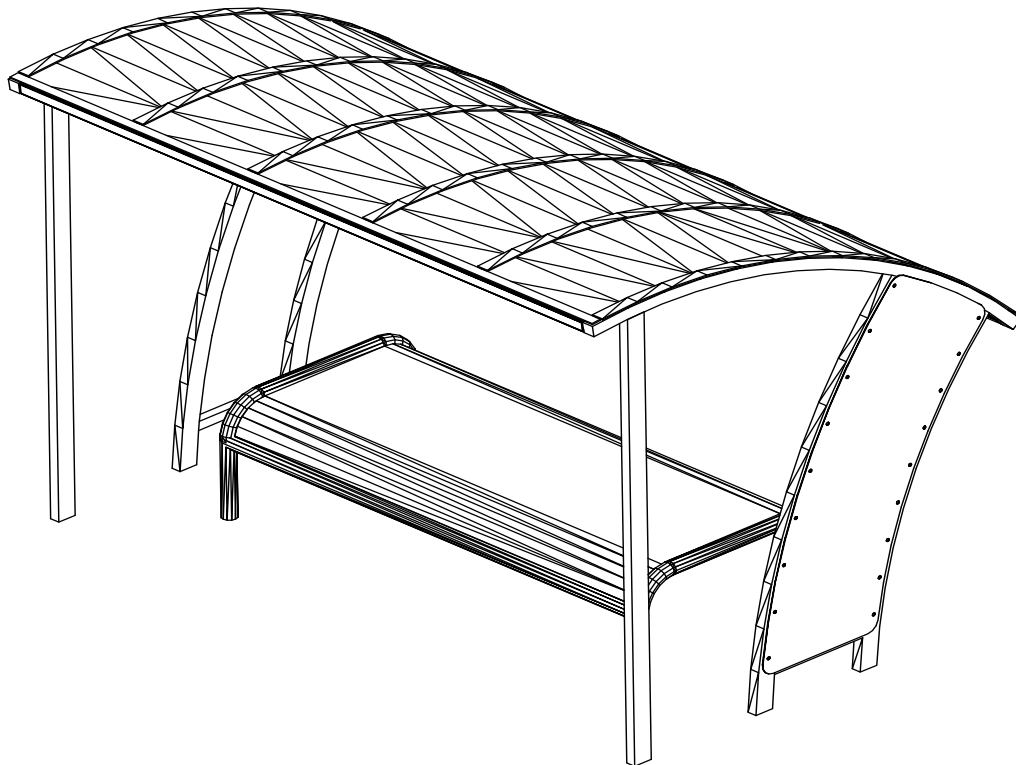

INSTALLATION INSTRUCTIONS

CHAT ROOM:- MPCHATRM

CHAT ROOM WITH SEAT:- MPCHATRS



INTENTIONALLY LEFT BLANK

1 SPECIFICATIONS

REFERENCE		MPCHATRM	MPCHATRS
OVERALL HEIGHT (H1)	m	2.090	
SEAT HEIGHT (H2)	m		0.530
LENGTH (L)	m	2.925	
WIDTH (W)	m	2.070	
WEIGHT	kg	380.0	480.0
HEAVIEST PART (SIDE FRAME)	kg	73.00	
LARGEST PART LxWxH (SIDE FRAME)	m	2.83x2.07x0.05	
CONCRETE	m ³	0.80	1.12
MANHOURS	hr	7	8
MANPOWER		3	3
CONSTRUCTIONAL SPACE	m	4 x 3	4 x 3

NOTE: All dimensions in metres.

Concrete mix is recommended at:
 1 part cement;
 2 parts sand;
 4 parts aggregate;
 by volume with 20mm aggregate
 (20 N/mm² min compressive strength)

Constructional Space (shown in the above table) is the approximate working area required to lay out and assemble the equipment.

This shelter is best installed with a suitable firm surface.

The concrete foundations indicated are for average ground. Care should be taken concerning abnormal conditions.

Tools: 5m tape measure, Spirit level, M10 Torx tool (Supplied with unit), Torque wrench.

Minimum Personal Protective Equipment: Hard hat, Gloves, Armoured boots.

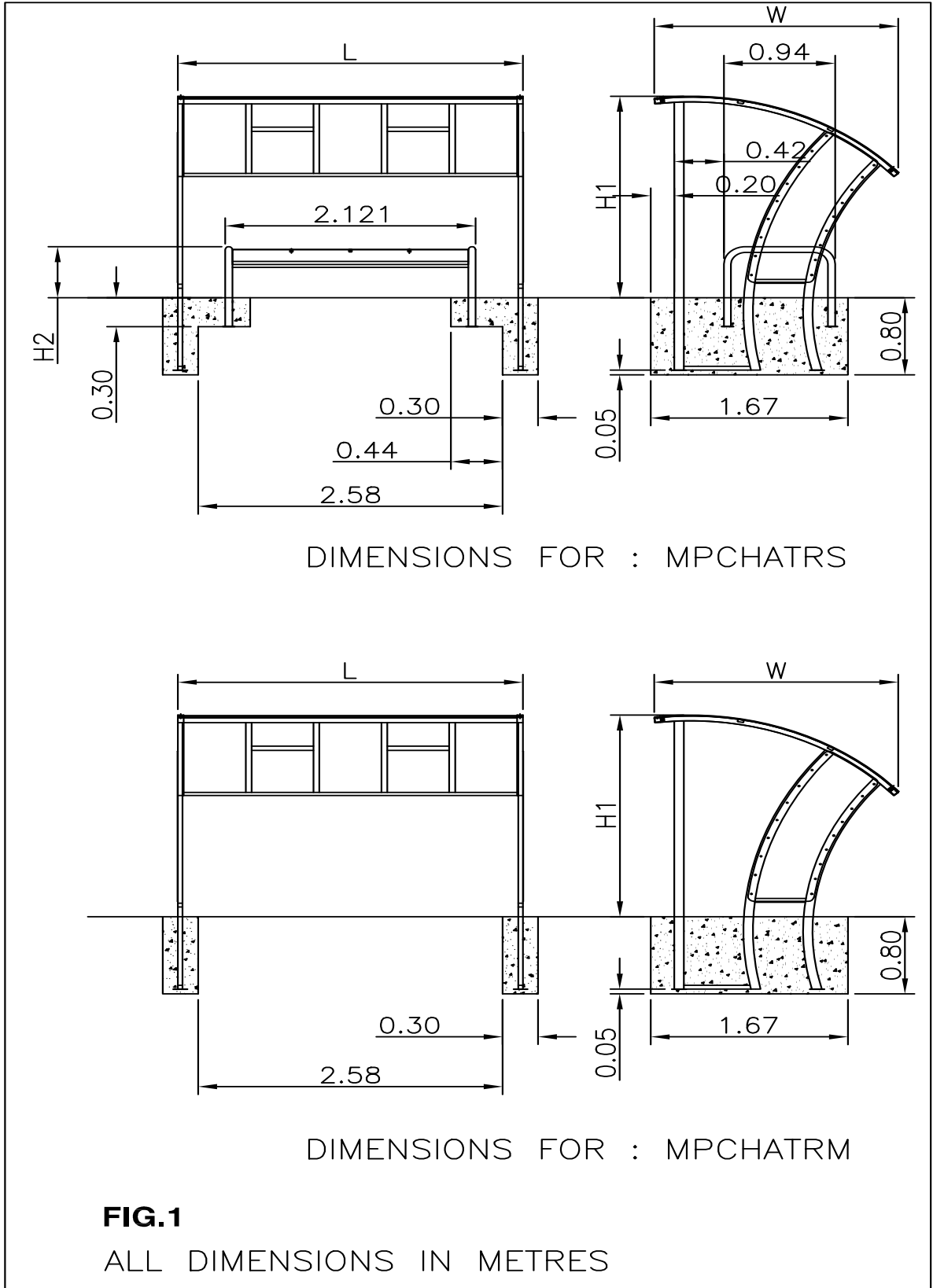
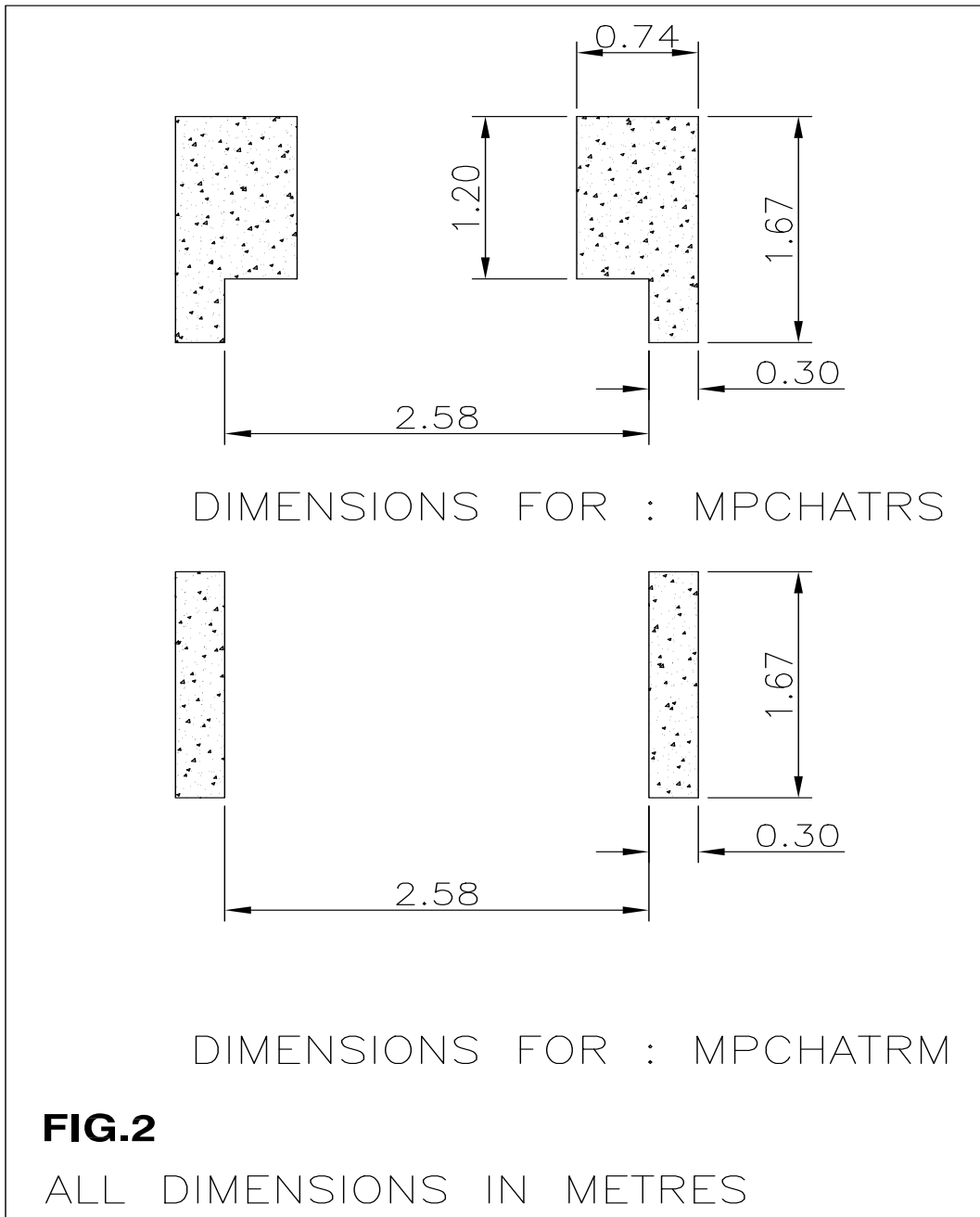

FIG.1

ALL DIMENSIONS IN METRES



2 PARTS LIST

UN-ASSEMBLED COMPONENTS					
ITEM	CODE	DESCRIPTION	MPCHATRM	MPCHATRS	WEIGHT (kg)
1.1	27000101	SIDE FRAME	2	2	73.000
1.2A	27000202	ROOF BEAM	2	2	3.500
1.2B	27000201	ROOF FRAME	2	2	30.500
1.3	27000903	SIDE PANEL	2	2	13.700
1.4	27000807	ROOF PANEL	5	5	19.800
1.5	27000808	ROOF STRAPS FRONT/REAR	2	2	4.600
1.6	27000809	ROOF CROSS STRAPS	6	6	4.300
1.7	27000301	SEAT		1	100.00
1.8	10121030	RESISTORX HEAD M10x30	88	88	0.028
1.9	10121020	RESISTORX HEAD M10x20	36	36	0.015
1.10	10291000	WASHER-PLAIN-M10	48	48	0.002
1.11	19027126	FOAM S/ADHESIVE STRIP-12mm X 6mm	2 ROLLS	2 ROLLS	-
1.12	10309999	HEAVY DUTY WASHER - M10	76	76	0.003

3 INSTALLATION & ASSY PROCEDURES

SAFE WORKING PRACTICE:

A full risk assessment should be carried out prior to commencing the installation, which will be specific to the site selected. The major risks associated with purely the assembly of this product are highlighted below, which can form part of the overall assessment.

RISKS:

- i) Large parts which could be difficult to lift or handle.
- ii) Steel sheets could have sharp edges.

CONTROL MEASURES

- i) Mechanical help to be utilised for any awkward lifting that may be required.
- ii) Wear suitable gloves.

3.1 PRE - INSTALLATION INSPECTION

Inspect all parts for damage (that may have occurred during transportation & storage). Finish Coatings, if found to be damaged these should be made good before erection (Refer to maintenance instructions). Any damaged or missing parts must be replaced. To ensure the required hole threads are free from contamination, it is recommended that they are cleaned out to save time on installation, if necessary using a M10 tap.

- i) Warn the public of the risk of injury, by placing signs and fencing the surrounding area, before commencing installation.

3.2 INSTALLATION.

- i) Mark out foundations and excavate the hole. (refer to site plan for unit location).

NOTE: If not using Chatroom seat, refer to the specified seat's individual foundation drawings for sizes.

- ii) Place one side frame (item 1.1) into excavation, pack up to height and attach front roof beam (item 1.2A) using 1 off M10 x 30 Resistorx bolt (item 1.8) and M10 washer (item 1.10).
- iii) Place second side frame (item 1.1) into excavation, pack up to height and attach to front roof beam (item 1.2A) using 1 off M10 x 30 Resistorx bolt (item 1.8) and M10 washer (item 1.10).
- iv) Attach rear roof beam (item 1.2A) to both side frames using 2 off M10 x 30 Resistorx bolts (items 1.8) and M10 washer (items 1.10). See Fig.3

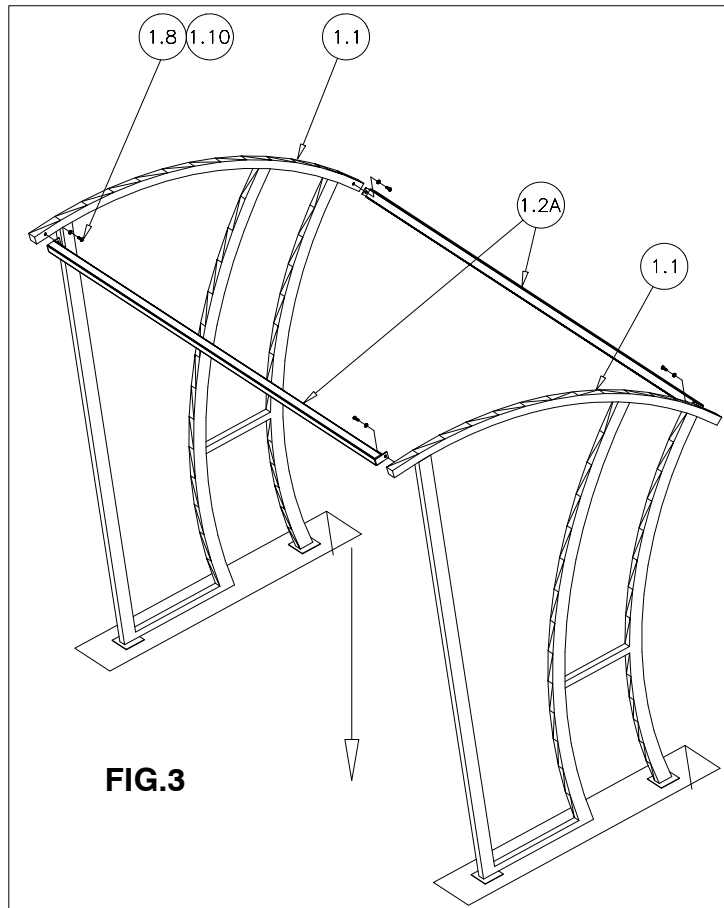

- v) Attach centre roof frames (items 1.2B) to front and rear roof beams using 8 off M10 x 30 Resistorx bolts (items 1.8) and M10 washers (items 1.10). See Fig.4.

NOTE: Check that all of structure is plumb and true and bolts have been tightened to a torque of 20-25Nm.

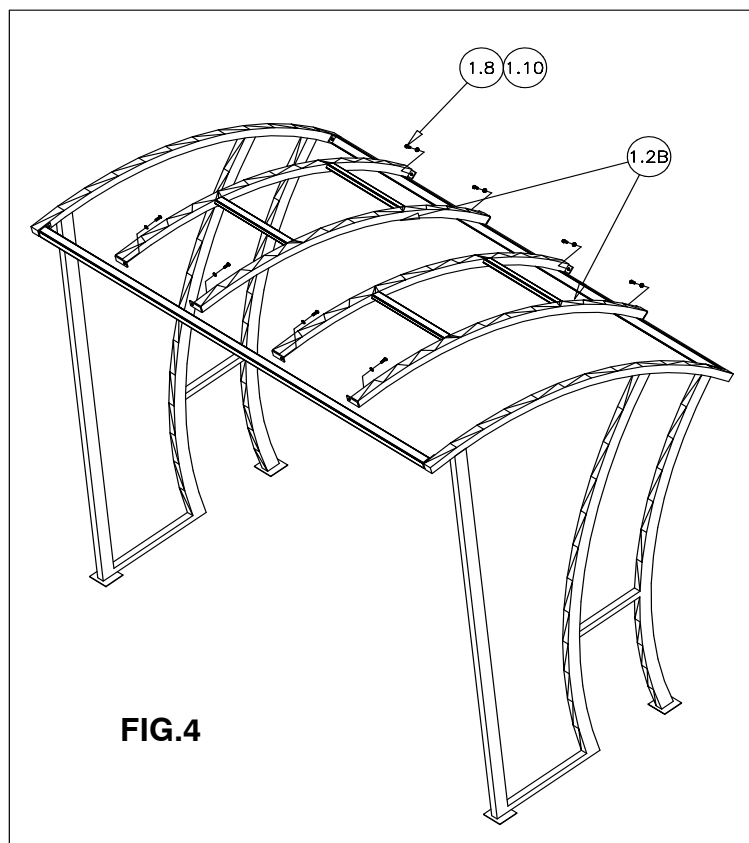

- vi) If specified place seat (item 1.7) into excavation, pack up to height. See Fig.5. For position of seat with relationship to main structure see Fig.1.

NOTE: If not using Chatroom seat, refer to the specified seat's drawings for position.

- vii) Fill holes with concrete. Ensure full volume of concrete is used, the top of which should slope down & outwards locally from the equipment frame to form a watershed. Allowance should be made for any special surfacing.

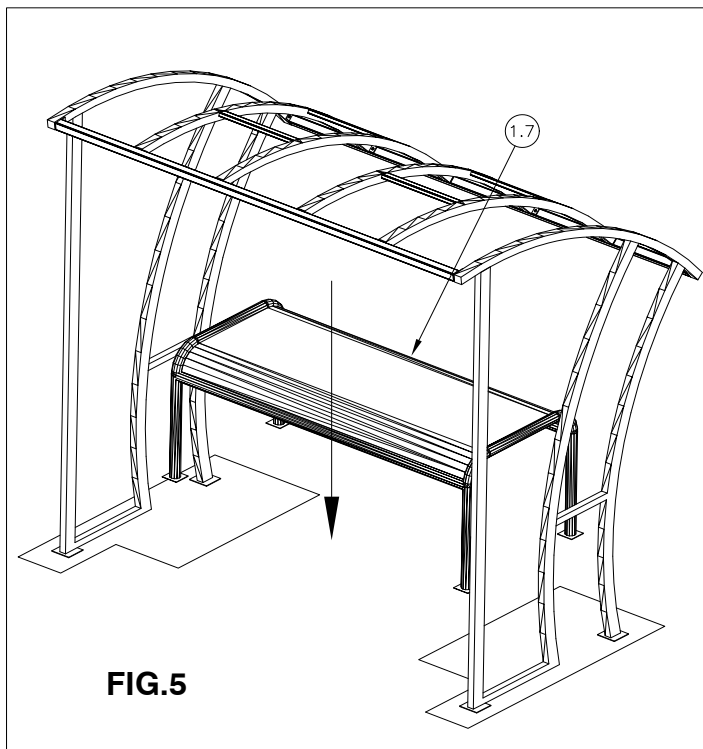

- viii) Keep installation off limits to the public until the concrete has completely cured. (Recommended initial curing time is 48 hours).
- ix) Attach side panels (items 1.3) to side frames (items 1.1) using 36 off M10 x 20 Resistorx bolts (items 1.9) and M10 washers (items 1.10). See Fig.6.

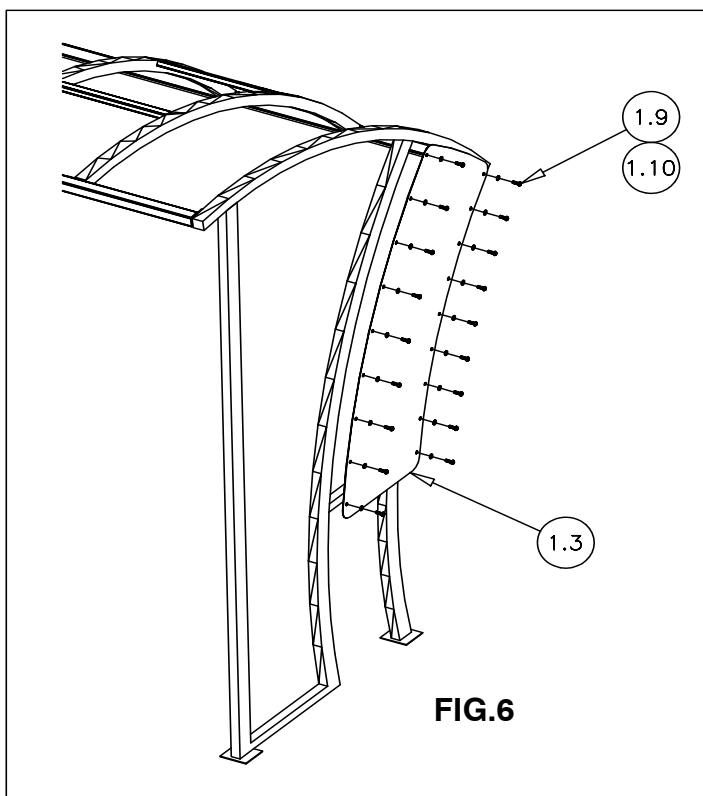

- x) Apply foam self adhesive strip (item 1.11) to both edges of the centre beams of the roof frame to provide a weather seal. See Fig.7.
- xi) Apply foam self adhesive strip (item 1.11) to inside edges at the perimeter of the roof frame front, rear and side beams to provide a weather seal. See Fig.8.
- xii) Carefully lay 1 off roof panel (item 1.4) at one end of roof frame on top of foam self adhesive strips, taking care not to dislodge them from the frame.
- xiii) Form to the curve of the roof, and hold loosely in position with 1 off M10 x 30 Resistorx bolts (items 1.8) and M10 washers (items 1.12) at each end of roof panel.
- xiv) Repeat for the 4 other roof panels
- xv) Starting from one end fix panels in position using roof cross straps (items 1.6) with 9 off M10 x 30 Resistorx bolts (items 1.8) and M10 washers (items 1.12) per strap working from the crown of the roof out to the front and rear beams. See Fig.7,8 & 9.
- xvi) Remove Resistorx bolts that were loosely holding the roof panels
- xvii) Bolt front and rear roof straps (item 1.5) in position with 11 off M10 x 30 Resistorx bolts (items 1.8) and M10 washers (items 1.12) per strap. See Fig.8 & 9.

NOTE: Ensure all bolts are fully tightened. The foam self adhesive strip should be compressed by the roof panels to provide a weather seal across the whole roof.

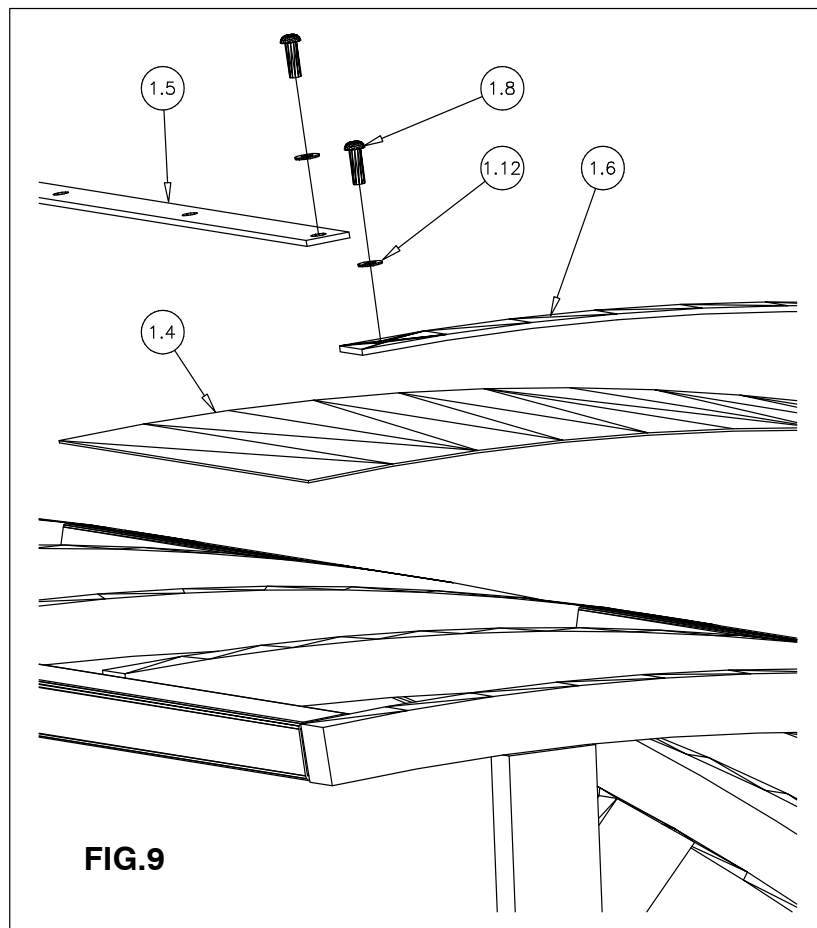
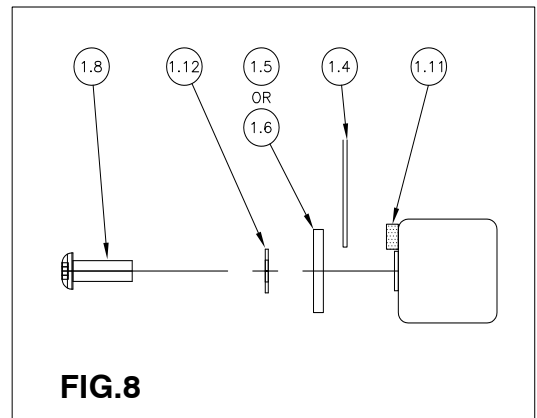
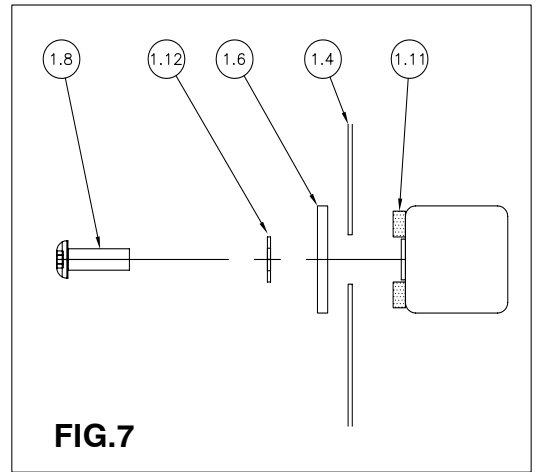

4 POST INSTALLATION INSPECTION

CHECK	CHECK	✓
1 The unit is installed at the correct height.	<input type="checkbox"/>	<input type="checkbox"/>
2 All fixings are tightened to the correct torque and have no protruding sharp edges.	<input type="checkbox"/>	<input type="checkbox"/>
3 All roof panels and securing straps are fully located - With sealing strip in position	<input type="checkbox"/>	<input type="checkbox"/>
4 Concrete foundations are secure.	<input type="checkbox"/>	<input type="checkbox"/>
5 Concrete has a water shed away from legs.	<input type="checkbox"/>	<input type="checkbox"/>
6 The surrounding surface is suitable. If a grass surface has been selected, ensure it is in good condition.	<input type="checkbox"/>	<input type="checkbox"/>
7 Site is clear of all tools and rubbish.	<input type="checkbox"/>	<input type="checkbox"/>
8 Remove any warning signs.	<input type="checkbox"/>	<input type="checkbox"/>